

AE TECHRON®



7548RLY / 7796RLY

Operator's Manual Supplement

For Variable Very-Low Impedance Loads in Controlled Current Mode

574.295.9495 | www.AETechron.com
2507 Warren Street, Elkhart, IN 46516

NOTE

This Supplement only provides information specific to the 7548RLY and 7796RLY models and is intended to be used together with the *AE Techron 7548 / 7796 Operator's Manual*. Please refer to the Operator's Manual for general information about safety, installation, operation and trouble-shooting.

1 Introduction

The 7548RLY / 7796RLY amplifiers are special models of the AE Techron 7548 or 7796 amplifier that have been modified to make them suitable for driving a Protection Relay or other variable very-low impedance loads in controlled-current mode.

1.1 Features

- Factory preset for Controlled Current Operation
- Multi-pole Compensation optimized for resistive loads below 2 ohms.

1.2 About AE Techron

AE Techron focuses on the development of power conversion and amplifier solutions for difficult environments. In addition to a line of standard power supplies and power amplifier products, AE Techron provides the design and manufacture of custom, high-quality, low-volume electronic products for research, military and industrial applications.

2 Factory Configuration (Default Settings)

Your 7548RLY/7796RLY amplifier differs from standard 7548 or 7796 amplifier in the following ways:

1. The 7548RLY/7796RLY ships with Controlled Current set as the default mode of operation.

Note that the amplifier operation mode can be changed to Controlled Voltage mode by adjusting the setting for Jumper J4, located on the amplifier main board (see the “Advanced Configuration” section of the **7548/7796 Operator's Manual**).

2. The 7548RLY/7796RLY ships with a multi-pole compensation enabled for the Controlled Current Mode Compensation Setting. The compensation is optimized for resistive loads below 2 ohms but is stable with higher impedances.

Note that the amplifier Compensation Setting can be changed to the standard 7548/7796 setting by adjusting the setting for Jumper J5, located on the amplifier main board board (see the “Advanced Configuration” section of the **7548/7796 Operator's Manual**).

**CAUTION**

The 7458RLY/7796RLY is designed for pulsed operation and should not be run at high power levels for long periods of time (greater than 5 minutes). Damage to components in the output of the amplifier can result from extended high-power usage (1,000 watts or above).

3 Setup, Operation and Troubleshooting

Please refer to the *AE Techron 7548/7796 Operator's Manual* for 7548RLY/7796RLY Setup Instructions. Note that the 7548RLY/7796RLY comes with the Mode setting pre-configured at the factory for Controlled Current Hook-up.

Please refer to the *AE Techron 7548/7796 Operator's Manual* for standard 7548RLY/7796RLY Operation and Troubleshooting instructions.

3.1 Main Board Functions and Jumper Settings (Rev 3, 7548RLY/7796RLY)

Please refer to the following for details of main board jumper functions and the factory default settings.

| KEY | NAME | REF. DES. | DESCRIPTION | FACTORY DEFAULT SETTING |
|-----|-------------------------|-----------------------|---|-------------------------|
| A | Voltage Monitor | TL3 | Observe the output voltage of the amplifier by connecting an oscilloscope and/or voltmeter from TL3, AMP OUT, to TL8 or TL18, GND,. This test point reads voltage directly. A 10 Ω resistor isolates it. | N/A |
| B | Master/Follower Jumpers | P1 and P2 | ASSUMES BOTH JUMPERS MOVED TOGETHER When the <i>MODEL 7548RLY/7796RLY</i> is used as a single amplifier or as a master in a multi-amp system, input is through the unbalanced BNC connector on the rear panel and the Master/Follower jumpers P1 and P2 will be in the Master (UP) position. If the amplifier is used as a follower in a multi-amp system, input will be through the interface connector J3, and the Master/Follower Jumpers P1 and P2 should be in the Follower (DOWN) position. | MASTER (UP) |
| C | CC/CV Jumper | J4 | This jumper goes RIGHT for Controlled Voltage (CV) mode, and LEFT for Controlled Current (CC) mode. By placing the jumper on the right pair of pins, the amplifier's output voltage will be controlled by its input voltage signal. By placing the jumper on the left pair of pins, the input voltage signal controls the output current. | CC (LEFT) |
| D | Compensation Jumper | J5 | The <i>MODEL 7548RLY/7796RLY</i> is factory-configured to be used in the CC mode as a controlled current amplifier. In CC mode, the current control loop is optimized with an RC network. The main board has provision for two of these networks. When J5 is in the DOWN position (default), the network CC2 (R82, C25) is selected. When J5 is in the UP position, the alternate network CC1 (R63, C16) is selected. NOTE: For RLY loads, the CC2 network must be used. | CC2 (DOWN) |
| E | Gain Trim Control | R210 | This is a multi-turn potentiometer that is used to calibrate the gain of the amplifier Turn clockwise to increase gain; turn counter-clockwise to lower gain. R232 resistor sets the coarse gain and R247 sets the range or sensitivity of R210. | N/A |
| F | Circuit Ground | GND, TL18 | This point is the signal ground to be used as a reference point for all measurements in the amplified signal path. | N/A |
| G | System Current Monitor | I _{fb} , TL2 | This is the total system current feedback point for amplifiers used in a multi-amplifier configuration. | N/A |
| H | Current Monitor | I MON, TL4 | The current monitor is an active buffered output observable with monitoring equipment. The scale factor is 20 Amps per Volt. Use GND (TL8), signal ground, with I MON (TL4) to monitor amplifier output current. | N/A |
| I | -TEMP and +TEMP | TL1 and | -TEMP and +TEMP are monitor points for the | N/A |

| KEY | NAME | REF. DES. | DESCRIPTION | FACTORY DEFAULT SETTING |
|-----|--------------------|--------------|--|--------------------------|
| | | TL10 | temperature sensors in the output wells. -TEMP is used for the negative and +TEMP is used for the positive wells. The output voltage is measured in Kelvin, with 10 millivolts per degree K. To convert readings to Celsius, subtract 273. | |
| J | ENABLE / STOP | J11 | The MODEL 7548RLY/7796RLY is factory-configured to automatically move into ENABLE mode on Start Up. In ENABLE mode, the amplifier will amplify an input signal. To place the amplifier in STOP mode on Start Up, move the jumper to the two RIGHT pins. When in STOP mode on Start Up, the amplifier will be placed in Standby mode until the front-panel ENABLE button is pressed or a remote ENABLE signal is received on the I/O Connector. To return the amplifier to ENABLE mode on Start Up, move the jumper to the two LEFT pins. | ENABLE (LEFT) |
| K | OT Latch | J12 | The MODEL 7548RLY/7796RLY is factory-configured with the OT Latch disabled. When a jumper is in place across the two pins labeled J12, any activation of the Over Temp circuit will cause the amplifier to move to a Stand By condition and to remain there until the amplifier is reset by pressing the front-panel RESET button, or until a remote RESET signal is presented on the I/O Connector, to return the amplifier to a Run/Ready (Operational) condition. | DISABLED (jumper absent) |
| L | OVL D Latch | J13 | The MODEL 7548RLY/7796RLY is factory-configured with the OVL D Latch disabled. When a jumper is in place across the two pins labeled J13, any activation of the IOC (Input Output Comparator), distortion alert circuit, (activation occurs at 0.5% error), will cause the amplifier to move to a Stand By condition. Once in Stand By, the amplifier must be reset by pressing the front-panel RESET button, or by presenting a remote RESET signal on the I/O Connector, to move the amplifier back to a Run/Ready (Operational) condition. | DISABLED (jumper absent) |
| M | FOLLOWER GAIN TRIM | R105 | In multiple follower amplifier systems, this single-turn potentiometer can be used to make minor gain adjustments (+/- 2%) to balance the gain with the rest of the system. Turn clockwise to increase gain; turn counter-clockwise to lower gain. | N/A |
| N | +VCC and -VCC | TL9 and TL11 | The point that the + (TL9) and - (TL11) voltage potential of the amplifier can be monitored. | N/A |

The following illustration, showing the main board with captioned call-outs, provides a visual location of main board functions (see Figure 3.1).

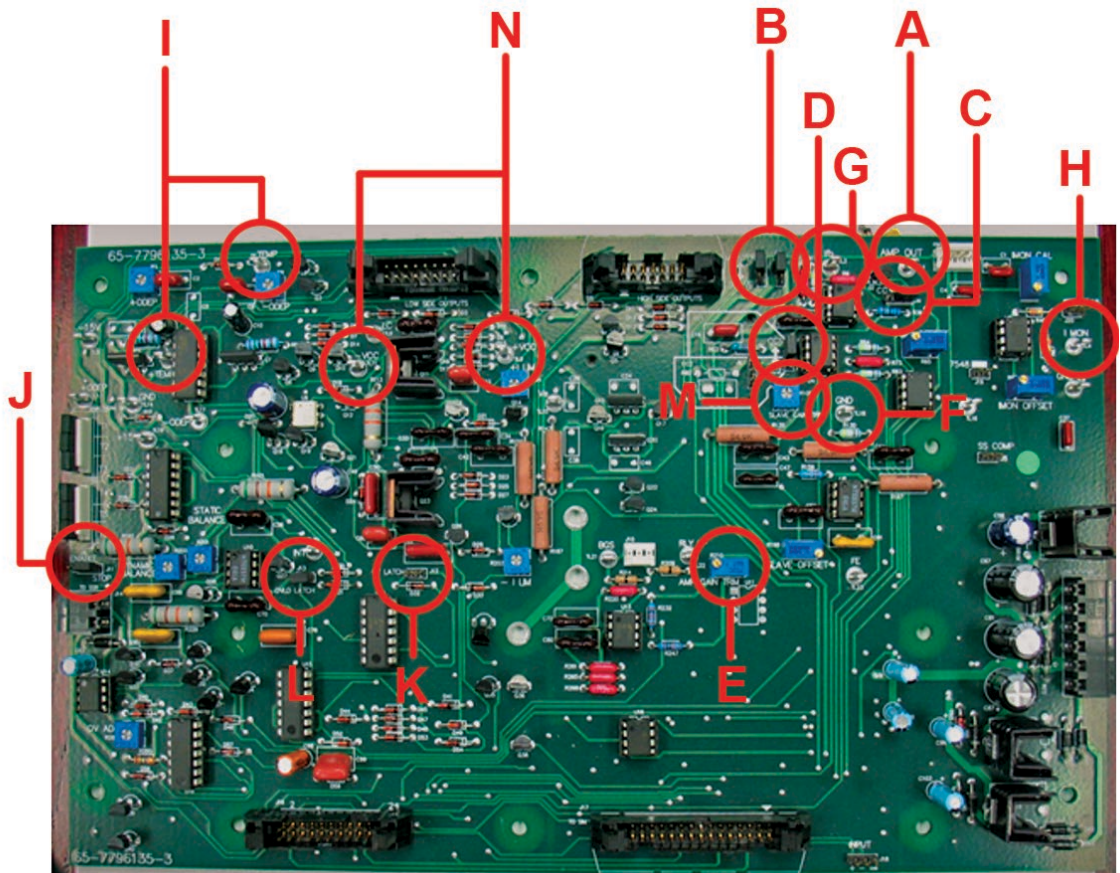

Figure 3.1 Main Board Component Locations

4 Accuracy

| Amplitude vs. Frequency at 1V input, 20A output, amplifier transconductance set to 20: | | | | |
|--|--------------|------------------|--------|--|
| Load | Input Signal | Transconductance | | |
| | | 1 kHz | 100 Hz | |
| 2 ohms | Sine | 19.9 | 20 | |
| 1 ohm | Sine | 20 | 20 | |
| ½ ohm | Sine | 20 | 20 | |
| Short (unimpeded wire) | Sine | 20 | 20 | |

5 Specifications

Please refer to the *AE Techron 7548/7796 Operator's Manual* "Specifications" section for basic amplifier performance, features and physical characteristics. The following specifications apply to a 7548RLY/7796RLY amplifier using the default factory settings.

7548 Pulse/Burst Specifications:

| Maximum Current: 70 Arms, 100 Apeak | | | |
|--|------------|------------|--------------------|
| Maximum Voltage: 195 Vpeak | | | |
| Total Load | Duration | Waveform | Output Power |
| 0.5 ohm | 20 seconds | 60 Hz Sine | 57 Arms/80.6 Apeak |
| | | DC | 25 Apeak |
| | 0.5 second | 60 Hz Sine | 66 Arms/93 Apeak |
| | | DC | 70 Apeak |
| | 0.2 second | 60 Hz Sine | 66 Arms/93 Apeak |
| | | DC | 70 Apeak |

7796 Pulse/Burst Specifications:

| Maximum Current: 141 Arms, 200 Apeak | | | |
|---|-----------------|-----------------|---------------------|
| Maximum Voltage: 183 Vpeak | | | |
| Total Load | Duration | Waveform | Output Power |
| 0.19 ohm | 20 seconds | 60 Hz Sine | 125 Arms/176 Apeak |
| | | DC | 60 Apeak |
| | 0.5 second | 60 Hz Sine | 141 Arms/200 Apeak |
| | | DC | 188 Apeak |
| | 0.2 second | 60 Hz Sine | 141 Arms/200 Apeak |
| | | DC | 188 Apeak |
| 0.53 ohm | 1 minute | 60 Hz Sine | 91A rms/128 Apeak |
| | | DC | 100 Apeak |
| | 0.5 second | 60 Hz Sine | 137A rms/193 Apeak |
| | | DC | 164 Apeak |
| | 0.2 second | 60 Hz Sine | 139 Arms/196 Apeak |
| | | DC | 164 Apeak |
| 1.07 ohm | 1 minute | 60 Hz Sine | 75A rms/107 Apeak |
| | | DC | 66 Apeak |
| | 0.5 second | 60 Hz Sine | 83A rms/118 Apeak |
| | | DC | 108 Apeak |
| | 0.2 second | 60 Hz Sine | 85A rms/120 Apeak |
| | | DC | 108 Apeak |

Maximum Output Current:**7548RLY:** 100 amps peak**7796RLY:** 200 amps peak**Maximum Output Voltage:****7548RLY:** 195 volts peak**7796RLY:** 183 volts peak**Maximum Output Power:**

Dependent on load and frequency

Load Constraint for Maximum Output:**7548RLY:** 0.5 ohms + 200 microhenries**7796RLY:** 0.19 ohms + 200 microhenries

* All loads from 8-ohm to short are stable with 2 mH in series.

Output Offset Current:

Less than 10.0 milliamperes DC peak

Input:**Standard Transconductance:** 20 \pm 0.2% from short to 1-ohm loads**Common Mode Rejection Ratio:** -58 dB minimum, 40-600Hz**Unit to Unit Phase Error:**Less than \pm 0.1 degrees at 60Hz**Residual Noise:**

Less than 2.5 milliamperes peak (40Hz - 600Hz)

Out Accuracy:Less than \pm 1%



Figure 5.2 7548RLY Back Panel

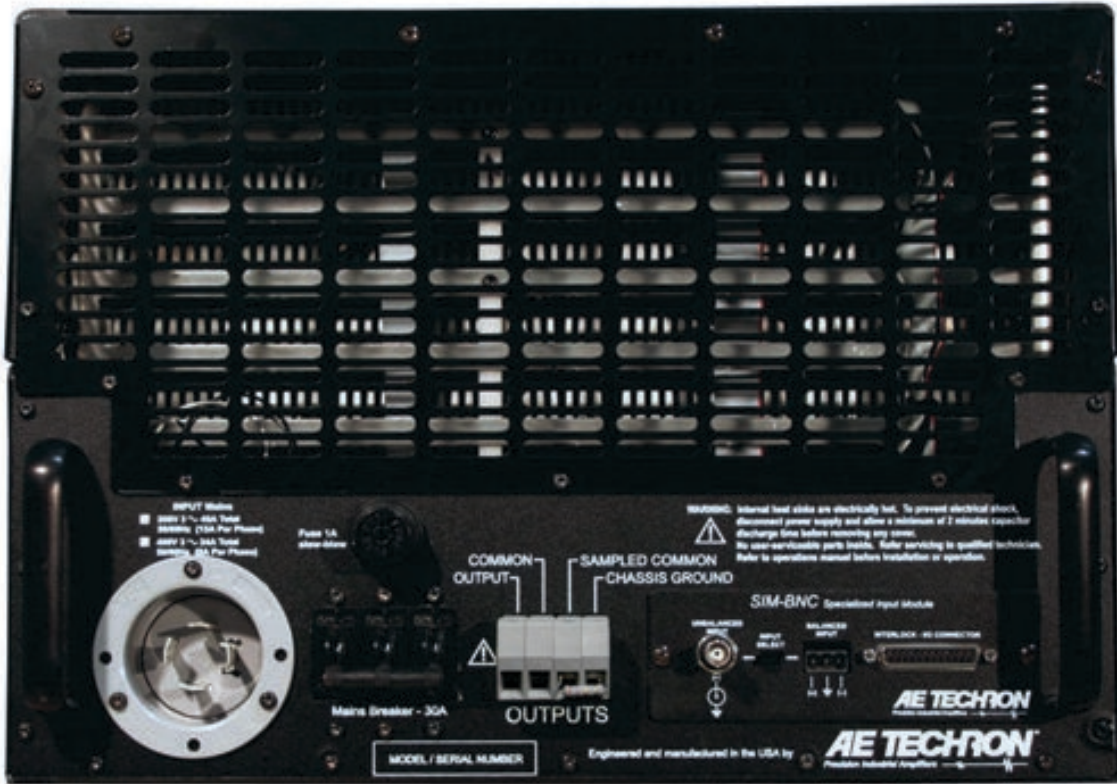

Figure 5.3 7796RLY Back Panel