

# COM-TECH®

## REFERENCE MANUAL

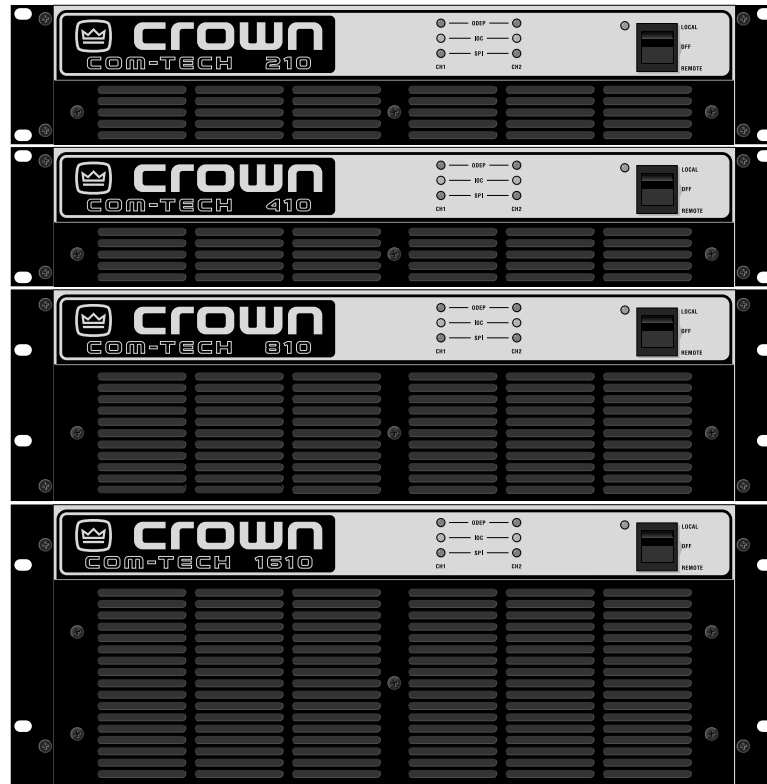

### Models:

Com-Tech 210, 410, 810 & 1610

Some models may be exported under the name *Amcron*®.

© 2001 by Crown Audio, Inc., P.O. Box 1000, Elkhart, IN 46515-1000 U.S.A. Telephone: 219-294-8000. Fax: 219-294-8329. Trademark Notice: *Amcron*®, *BCA*® and *Crown*® are registered trademarks of Crown International, Inc. Other trademarks are the property of their respective owners.

#### Obtaining Other Language Versions:

To obtain information in another language about the use of this product, please contact your local Crown Distributor. If you need assistance locating your local distributor, please contact Crown at 219-294-8200.

**Note:** The information provided in this manual was deemed accurate as of the publication date. However, updates to this information may have occurred. To obtain the latest version of this manual, please visit the Crown website at [www.crownaudio.com](http://www.crownaudio.com).



Applies to  
CT-410 and CT-810  
Crown and Amcron  
models

This page intentionally left blank

## Important Safety Instructions

- 1) Read these instructions.
- 2) Keep these instructions.
- 3) Heed all warnings.
- 4) Follow all instructions.
- 5) Do not use this apparatus near water.
- 6) Clean only with a dry cloth.
- 7) Do not block any ventilation openings. Install in accordance with the manufacturer's instructions.
- 8) Do not install near any heat sources such as radiators, heat registers, stoves, or other apparatus that produce heat.
- 9) Do not defeat the safety purpose of the polarized or grounding-type plug. A polarized plug has two blades with one wider than the other. A grounding-type plug has two blades and a third grounding prong. The wide blade or the third prong is provided for your safety. If the provided plug does not fit into your outlet, consult an electrician for replacement of the obsolete outlet.
- 10) Protect the power cord from being walked on or pinched, particularly at plugs, convenience receptacles, and the point where they exit from the apparatus.
- 11) Only use attachments/accessories specified by the manufacturer.
- 12) Use only with a cart, stand, bracket, or table specified by the manufacturer, or sold with the apparatus. When a cart is used, use caution when moving the cart/apparatus combination to avoid injury from tip-over.
- 13) Unplug this apparatus during lightning storms or when unused for long periods of time.
- 14) Refer all servicing to qualified service personnel. Servicing is required when the apparatus has been damaged in any way, such as power-supply cord or plug is damaged, liquid has been spilled or objects have fallen into the apparatus, the apparatus has been exposed to rain or moisture, does not operate normally, or has been dropped.
- 15) To reduce the risk of fire or electric shock, do not expose this apparatus to rain or moisture.





# THREE YEAR FULL WARRANTY



## WORLDWIDE

### SUMMARY OF WARRANTY

The Crown Audio Division of Crown International, Inc., 1718 West Mishawaka Road, Elkhart, Indiana 46517-4095 U.S.A. warrants to you, the ORIGINAL PURCHASER and ANY SUBSEQUENT OWNER of each NEW Crown<sup>1</sup> product, for a period of three (3) years from the date of purchase by the original purchaser (the "warranty period") that the new Crown product is free of defects in materials and workmanship, and we further warrant the new Crown product regardless of the reason for failure, except as excluded in this Crown Warranty.

<sup>1</sup> Note: If your unit bears the name "Amcron," please substitute it for the name "Crown" in this warranty.

### ITEMS EXCLUDED FROM THIS CROWN WARRANTY

This Crown Warranty is in effect only for failure of a new Crown product which occurred within the Warranty Period. It does not cover any product which has been damaged because of any intentional misuse, accident, negligence, or loss which is covered under any of your insurance contracts. This Crown Warranty also does not extend to the new Crown product if the serial number has been defaced, altered, or removed.

### WHAT THE WARRANTOR WILL DO

We will remedy any defect, regardless of the reason for failure (except as excluded), by repair, replacement, or refund. We may not elect refund unless you agree, or unless we are unable to provide replacement, and repair is not practical or cannot be timely made. If a refund is elected, then you must make the defective or malfunctioning product available to us free and clear of all liens or other encumbrances. The refund will be equal to the actual purchase price, not including interest, insurance, closing costs, and other finance charges less a reasonable depreciation on the product from the date of original purchase. Warranty work can only be performed at our authorized service centers. We will remedy the defect and ship the product from the service center within a reasonable time after receipt of the defective product at our authorized service center.

### HOW TO OBTAIN WARRANTY SERVICE

You must notify us of your need for warranty service not later than ninety (90) days after expiration of the warranty period. All components must be shipped in a factory pack. Corrective action will be taken within a reasonable time of the date of receipt of the defective product by our authorized service center. If the repairs made by our authorized service center are not satisfactory, notify our authorized service center immediately.

**DISCLAIMER OF CONSEQUENTIAL AND INCIDENTAL DAMAGES**  
YOU ARE NOT ENTITLED TO RECOVER FROM US ANY INCIDENTAL DAMAGES RESULTING FROM ANY DEFECT IN THE NEW CROWN PRODUCT. THIS INCLUDES ANY DAMAGE TO ANOTHER PRODUCT OR PRODUCTS RESULTING FROM SUCH A DEFECT.

### WARRANTY ALTERATIONS

No person has the authority to enlarge, amend, or modify this Crown Warranty. This Crown Warranty is not extended by the length of time which you are deprived of the use of the new Crown product. Repairs and replacement parts provided under the terms of this Crown Warranty shall carry only the unexpired portion of this Crown Warranty.

### DESIGN CHANGES

We reserve the right to change the design of any product from time to time without notice and with no obligation to make corresponding changes in products previously manufactured.

### LEGAL REMEDIES OF PURCHASER

No action to enforce this Crown Warranty shall be commenced later than ninety (90) days after expiration of the warranty period.

**THIS STATEMENT OF WARRANTY SUPERSEDES ANY OTHERS CONTAINED IN THIS MANUAL FOR CROWN PRODUCTS.**

9/90

Telephone: 219-294-8200. Facsimile: 219-294-8301

## NORTH AMERICA

### SUMMARY OF WARRANTY

The Crown Audio Division of Crown International, Inc., 1718 West Mishawaka Road, Elkhart, Indiana 46517-4095 U.S.A. warrants to you, the ORIGINAL PURCHASER and ANY SUBSEQUENT OWNER of each NEW Crown product, for a period of three (3) years from the date of purchase by the original purchaser (the "warranty period") that the new Crown product is free of defects in materials and workmanship. We further warrant the new Crown product regardless of the reason for failure, except as excluded in this Warranty.

### ITEMS EXCLUDED FROM THIS CROWN WARRANTY

This Crown Warranty is in effect only for failure of a new Crown product which occurred within the Warranty Period. It does not cover any product which has been damaged because of any intentional misuse, accident, negligence, or loss which is covered under any of your insurance contracts. This Crown Warranty also does not extend to the new Crown product if the serial number has been defaced, altered, or removed.

### WHAT THE WARRANTOR WILL DO

We will remedy any defect, regardless of the reason for failure (except as excluded), by repair, replacement, or refund. We may not elect refund unless you agree, or unless we are unable to provide replacement, and repair is not practical or cannot be timely made. If a refund is elected, then you must make the defective or malfunctioning product available to us free and clear of all liens or other encumbrances. The refund will be equal to the actual purchase price, not including interest, insurance, closing costs, and other finance charges less a reasonable depreciation on the product from the date of original purchase. Warranty work can only be performed at our authorized service centers or at the factory. We will remedy the defect and ship the product from the service center or our factory within a reasonable time after receipt of the defective product at our authorized service center or our factory. All expenses in remedying the defect, including surface shipping costs in the United States, will be borne by us. (You must bear the expense of shipping the product between any foreign country and the port of entry in the United States and all taxes, duties, and other customs fees for such foreign shipments.)

### HOW TO OBTAIN WARRANTY SERVICE

You must notify us of your need for warranty service not later than ninety (90) days after expiration of the warranty period. All components must be shipped in a factory pack, which, if needed, may be obtained from us free of charge. Corrective action will be taken within a reasonable time of the date of receipt of the defective product by us or our authorized service center. If the repairs made by us or our authorized service center are not satisfactory, notify us or our authorized service center immediately.

**DISCLAIMER OF CONSEQUENTIAL AND INCIDENTAL DAMAGES**  
YOU ARE NOT ENTITLED TO RECOVER FROM US ANY INCIDENTAL DAMAGES RESULTING FROM ANY DEFECT IN THE NEW CROWN PRODUCT. THIS INCLUDES ANY DAMAGE TO ANOTHER PRODUCT OR PRODUCTS RESULTING FROM SUCH A DEFECT. **SOME STATES DO NOT ALLOW THE EXCLUSION OR LIMITATIONS OF INCIDENTAL OR CONSEQUENTIAL DAMAGES, SO THE ABOVE LIMITATION OR EXCLUSION MAY NOT APPLY TO YOU.**

### WARRANTY ALTERATIONS

No person has the authority to enlarge, amend, or modify this Crown Warranty. This Crown Warranty is not extended by the length of time which you are deprived of the use of the new Crown product. Repairs and replacement parts provided under the terms of this Crown Warranty shall carry only the unexpired portion of this Crown Warranty.

### DESIGN CHANGES

We reserve the right to change the design of any product from time to time without notice and with no obligation to make corresponding changes in products previously manufactured.

### LEGAL REMEDIES OF PURCHASER

THIS CROWN WARRANTY GIVES YOU SPECIFIC LEGAL RIGHTS, YOU MAY ALSO HAVE OTHER RIGHTS WHICH VARY FROM STATE TO STATE. No action to enforce this Crown Warranty shall be commenced later than ninety (90) days after expiration of the warranty period.

**THIS STATEMENT OF WARRANTY SUPERSEDES ANY OTHERS CONTAINED IN THIS MANUAL FOR CROWN PRODUCTS.**

Telephone: 219-294-8200. Facsimile: 219-294-8301

9/90

The information furnished in this manual does not include all of the details of design, production, or variations of the equipment. Nor does it cover every possible situation which may arise during installation, operation or maintenance. If your unit bears the name "Amcron," please substitute it for the name "Crown" in this manual. If you need special assistance beyond the scope of this manual, please contact our Technical Support Group.

### Crown Technical Support Group

Plant 2 SW, 1718 W. Mishawaka Rd., Elkhart, Indiana 46517 U.S.A.  
Phone: **800-342-6939** (North America, Puerto Rico and Virgin Islands) or 219-294-8200  
Fax: 219-294-8301 Internet: <http://www.crownaudio.com>

#### CAUTION

**RISK OF ELECTRIC SHOCK  
DO NOT OPEN**

**TO PREVENT ELECTRIC SHOCK DO NOT REMOVE TOP OR BOTTOM COVERS. NO USER SERVICEABLE PARTS INSIDE. REFER SERVICING TO QUALIFIED SERVICE PERSONNEL. DISCONNECT POWER CORD BEFORE REMOVING REAR INPUT MODULE TO ACCESS GAIN SWITCH.**

#### AVIS

**RISQUE DE CHOC ÉLECTRIQUE  
N'OUVREZ PAS**

**À PRÉVENIR LE CHOC ÉLECTRIQUE N'ENLEVEZ PAS LES COUVERCLES. IL N'Y A PAS DES PARTIES SERVICEABLE À L'INTÉRIEUR. TOUS REPARATIONS DOIT ÊTRE FAIRE PAR PERSONNEL QUALIFIÉ SEULEMENT. DÉBRANCHER LA BORNE AVANT D'OUVRIR LA MODULE EN ARRIÈRE.**



#### WARNING

**TO REDUCE THE RISK OF ELECTRIC SHOCK, DO NOT EXPOSE THIS EQUIPMENT TO RAIN OR MOISTURE!**

#### Magnetic Field

**CAUTION!** Do not locate sensitive high-gain equipment such as preamplifiers or tape decks directly above or below the unit. Because this amplifier has a high power density, it has a strong magnetic field which can induce hum into unshielded devices that are located nearby. The field is strongest just above and below the unit.

If an equipment rack is used, we recommend locating the amplifier(s) in the bottom of the rack and the preamplifier or other sensitive equipment at the top.

#### WATCH FOR THESE SYMBOLS:



The lightning bolt triangle is used to alert the user to the risk of electric shock.



The exclamation point triangle is used to alert the user to important operating or maintenance instructions.



Printed on recycled paper.

# CONTENTS

<b>1</b>	<b>Welcome .....</b>	<b>9</b>
1.1	Unpacking .....	9
1.2	Features .....	9
<b>2</b>	<b>Facilities .....</b>	<b>10</b>
<b>3</b>	<b>Installation .....</b>	<b>12</b>
3.1	Mounting .....	12
3.2	Cooling .....	12
3.2.1	Cooling for Units without Internal Fans .....	13
3.2.2	Additional Cooling for Units with Internal Fans ..	13
3.3	Wiring .....	14
3.3.1	Mode of Operation .....	14
3.3.2	Audio Input Connection .....	19
3.3.3	RSVP Input Connections .....	21
3.3.4	Output Connection .....	21
3.3.5	Additional Load Protection .....	23
3.4	AC Power Requirements .....	24
<b>4</b>	<b>Operation .....</b>	<b>25</b>
4.1	Precautions .....	25
4.2	Indicators .....	25
4.3	Protection Systems .....	26
4.3.1	ODEP .....	26
4.3.2	Standby Mode .....	27
4.3.3	Transformer Thermal Protection .....	27
4.3.4	Circuit Breaker .....	27
4.4	Controls .....	28
4.5	Energy Savings Circuit Application .....	29
4.6	Filter Cleaning .....	29
<b>5</b>	<b>Technical Information .....</b>	<b>29</b>
5.1	Overview .....	29
5.2	Circuit Theory .....	30
5.2.1	Dual Operation .....	30
5.2.2	Bridge-Mono Operation .....	31
5.2.3	Parallel-Mono Operation .....	31
<b>6</b>	<b>Specifications .....</b>	<b>32</b>
<b>7</b>	<b>AC Power Draw and Thermal Dissipation .....</b>	<b>45</b>
<b>8</b>	<b>Accessories .....</b>	<b>47</b>
8.1	PIP and PIP2 Modules .....	47
8.2	RSVP Module .....	49
8.3	Cooling Fan Option (120 VAC, 60 Hz only) .....	49
8.4	Constant Voltage Computer .....	49
<b>9</b>	<b>Service .....</b>	<b>50</b>
9.1	Worldwide Service .....	50
9.2	North American Service .....	50
9.2.1	Service at a North American Service Center .....	50
9.2.2	Factory Service .....	50

## ILLUSTRATIONS

1.1	Com-Tech Amplifiers (120 VAC, 60 Hz Units)	8
2.1	Front Facilities	10
2.2	Rear Facilities	11
3.1	Mounting Dimensions	12
3.2	Top View of a Rack-Mounted Unit	13
3.3	Extra Cooling with a Rack-Mounted Blower	14
3.4	Wiring for Dual 8/4 Ohm Mode	15
3.5	Wiring for Dual 70 Volt Mode	16
3.6	Wiring for Bridge-Mono 70 Volt Mode (140 Volt Output)	17
3.7	Wiring for Parallel-Mono 70 Volt, Bridge-Mono 8/4 Ohm and Parallel-Mono 8/4 Ohm Modes	18
3.8	Balanced Input Wiring	19
3.9	Unbalanced Input Wiring	19
3.10	Infrasonic Filter Capacitor Values	20
3.11	Unbalanced RFI Filters	20
3.12	Balanced RFI Filters	20
3.13	Connecting the RSVP Module	21
3.14	Wire Size Nomograph	22
3.15	Inductive Load (Transformer) Network	23
3.16	Loudspeaker Fuse Nomograph	24
4.1	Indicators	25
4.2	ODEP, IOC and Signal Presence Indicator States	26
4.3	Input Sensitivity Switch	28
5.1	Circuit Block Diagram	30
6.1	Com-Tech 210 Minimum Power Matrix	35
6.2	Com-Tech 410 Minimum Power Matrix	36
6.3	Com-Tech 810 Minimum Power Matrix	37
6.4	Com-Tech 1610 Minimum Power Matrix	38
6.5	Com-Tech 210 Maximum Power Matrix	39
6.6	Com-Tech 410 Maximum Power Matrix	40
6.7	Com-Tech 810 Maximum Power Matrix	41
6.8	Com-Tech 1610 Maximum Power Matrix	42
6.9	Typical Frequency Response	43
6.10	Typical Damping Factor	43
6.11	Typical Output Impedance	43
6.12	Typical Phase Response	44
6.13	Typical Crosstalk	44
7.1	Com-Tech 210 Power Draw, Current Draw and Thermal Dissipation at Various Duty Cycles	45
7.2	Com-Tech 410 Power Draw, Current Draw and Thermal Dissipation at Various Duty Cycles	46
7.3	Com-Tech 810 Power Draw, Current Draw and Thermal Dissipation at Various Duty Cycles	46
7.4	Com-Tech 1610 Power Draw, Current Draw and Thermal Dissipation at Various Duty Cycles	46
8.1	PIP2 Adaptor Connection	47
8.2	Installing a PIP Module	47

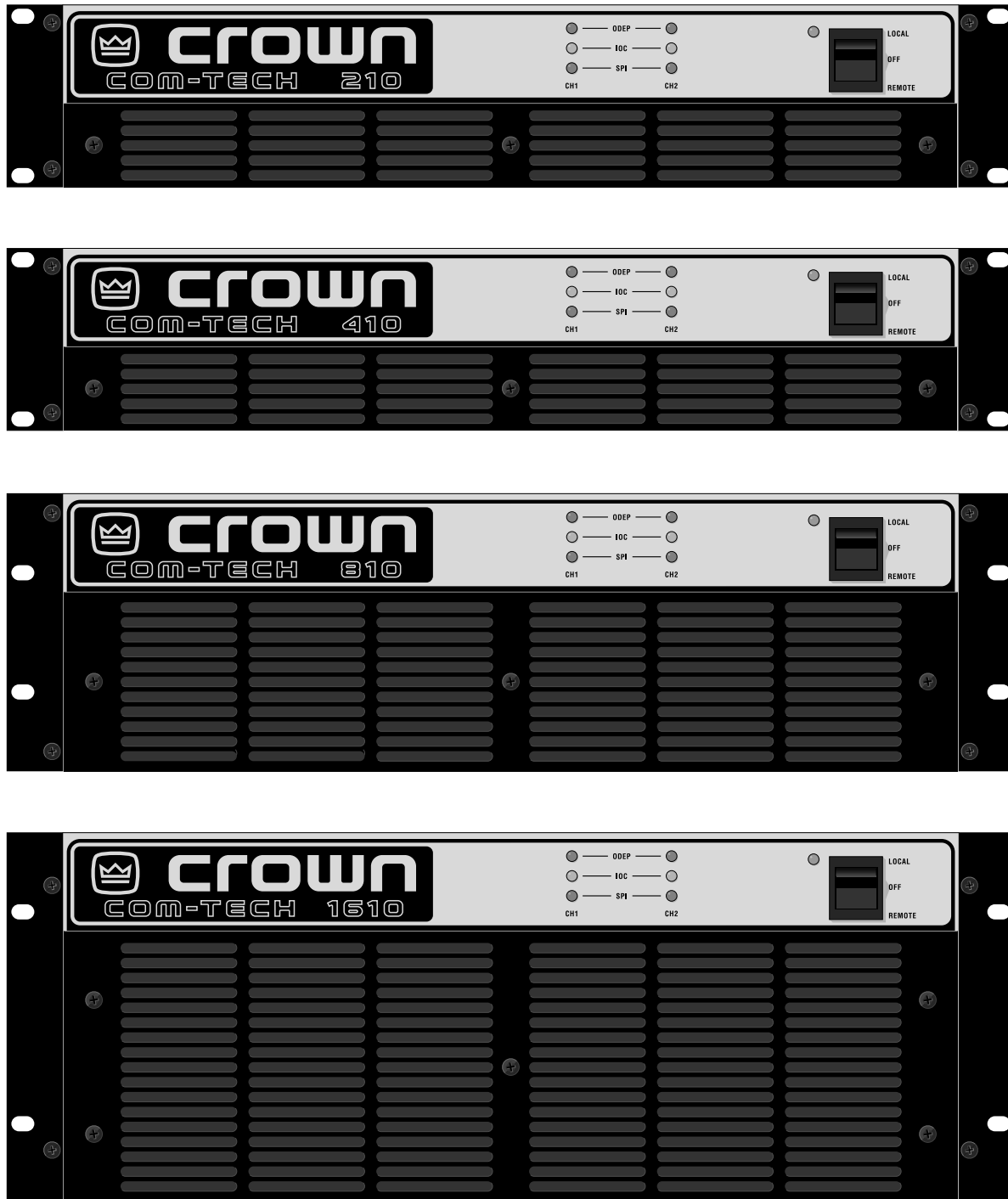

Fig. 1.1 Com-Tech Amplifiers (120 VAC, 60 Hz Units)



# 1 Welcome

Congratulations on your purchase of a Com-Tech® commercial power amplifier. The Com-Tech series is a complete family of amplifiers with a wide range of power output capabilities. Com-Tech amplifiers can directly drive “constant voltage” lines, so you can avoid the expense, distortion and insertion loss associated with step-up transformers for distributed loudspeaker systems. Com-Tech amplifiers also utilize Crown’s patented ODEP® protection circuitry which *keeps the amplifier working* under severe conditions that would shut down a lesser amplifier. All Com-Tech amplifiers feature Crown’s exclusive PIP™ (Programmable Input Processor) expansion system. The PIP expansion system makes it easy to tailor your amplifier to a specific application or to add future technology as it develops (see Section 8 for a list of available PIPs).

This manual will help you successfully install and use your new Com-Tech amplifier. Please read all instructions, warnings and cautions. Be sure to read Section 3.3.1 if you plan to use the amplifier in one of its two mono modes, or if you plan to drive “constant voltage” lines. Also, for your protection, please send in your warranty registration card today, and save your bill of sale as it is your **official proof of purchase**.

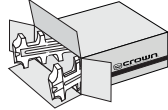

## 1.1 Unpacking

Please unpack and inspect your new amplifier for any damage that may have occurred during transit. If damage is found, notify the transportation company immediately. Only you, the consignee, may initiate a claim for shipping damage. Crown will be happy to cooperate fully, as needed. Save the shipping carton as evidence of damage for the shipper’s inspection.

Even if the unit arrived in perfect condition, (as most do), save all packing materials, so you will have them if you ever need to transport the unit. **NEVER SHIP THE UNIT WITHOUT THE FACTORY PACK.**

## 1.2 Features

Com-Tech amplifiers use cutting-edge technology and miniaturized design to provide the highest power and value for its size, weight and price. They offer numerous advantages over conventional designs and provide benefits you can’t get in amplifiers from any other manufacturer. For example, Crown’s patented ODEP protection circuitry and *grounded bridge™* output stages combine to provide performance and reliability that surpass the other, more traditional, designs. Here are some more of your amplifier’s impressive features:

- ❑ **“Soft-Start”** inrush current limiting protects the house circuit breaker when several amps are turned on simultaneously.
- ❑ **Remote** feature allows CT-10 Series amplifiers to be turned on and off from a remote location. Placing the Enable switch on the amplifier’s front panel to the Remote position allows the optional *R.S.V.P.* (Remote Switching Voltage Provider) module to control the amplifier.
- ❑ **Energy Saving** circuit allows a CT-10 Series amplifier to cut back its energy consumption based on the signal level offered to the inputs.
- ❑ Crown’s patented ODEP (Output Device Emulation Protection) circuitry detects and compensates for overheating and overload to keep the amplifier working when others would fail.
- ❑ Crown’s grounded bridge design delivers incredible voltage swings without using stressful output transistor configurations like conventional amplifiers. The results are lower distortion and superior reliability.
- ❑ *IOC®* (Input/Output Comparator) circuitry immediately alerts you if distortion is present. You have real-time *proof of distortion-free performance*.
- ❑ **Enhanced PIP2** (Programmable Input Processor) connector accepts new accessory modules that further tailor the amplifier to suit specific applications, including **wideband load current monitoring**.
- ❑ Drives constant voltage lines without “lossy,” distortion-producing step-up transformers.
- ❑ Two mono modes (Bridge-Mono and Parallel-Mono) for driving a wide range of load impedances.
- ❑ Very low harmonic and intermodulation distortion give the best *dynamic transfer function* in the industry.
- ❑ Superior damping factor delivers maximum loudspeaker motion control for a clean, accurate low end.
- ❑ Superb crosstalk characteristics and a separate voltage supply for each channel make it possible to treat each channel like a separate amplifier.
- ❑ Full protection from shorted, open and mismatched loads, general overheating. DC, high-frequency overloads, and full internal fault protection are provided by our latest protection scheme: **“Quad-Mute.”**
- ❑ Efficient heat sinks and a **fully proportional speed fan** dissipate heat quickly and evenly for extra amplifier protection and extended component life. (The fan is an option for 120 VAC, 60 Hz *Com-Tech 210s*.)
- ❑ Barrier blocks are provided for both input and output connections. New input barrier blocks incorporate a **test point** for a DVM.
- ❑ Internal three-position input sensitivity switch provides settings of 0.775 volts for full standard 1-kHz 8/4-ohm power, 0.775 volts for full standard 1-kHz 70-volt power, and 26-dB voltage gain.
- ❑ Mounts in a standard 19-inch (48.3-cm) equipment rack.
- ❑ Three year “No-Fault” full warranty completely protects your investment and guarantees its specifications.

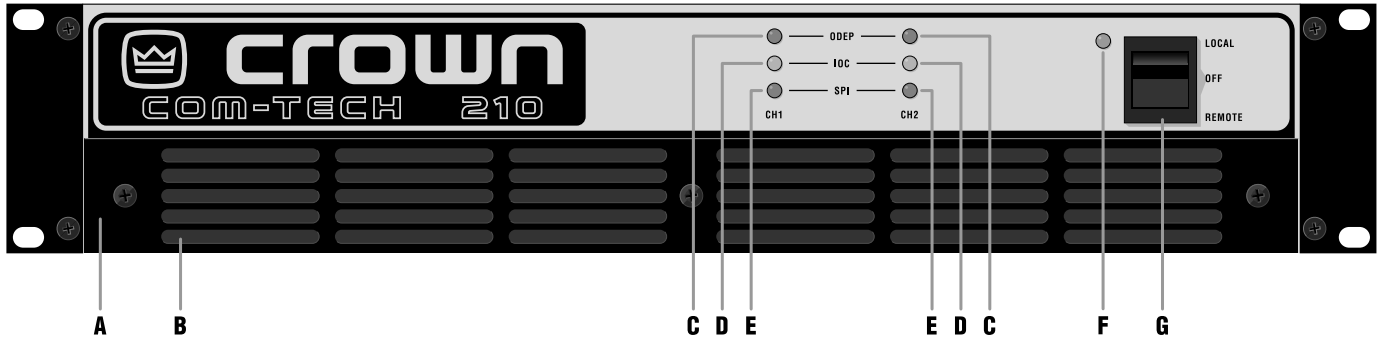

Fig. 2.1 Front Facilities

## 2 Facilities

### A. Filter Grille

A metal grille supports and protects the dust filter (B). To clean the dust filter, detach the grille by removing the screws that fasten it in place.

### B. Dust Filter

The dust filter removes large particles from air drawn by the cooling fan. (The fan is an option for 120 VAC, 60 Hz Com-Tech 210s.) Clean the filter regularly to prevent clogging (see Section 4.5).

### C. ODEP Indicators

Each channel has an amber front panel indicator that shows thermal-dynamic energy reserve. Normally, each ODEP indicator is lit to show available reserve energy. The indicator will dim proportionally as the energy reserve for its channel decreases. In the rare event that a channel has no reserve, its indicator will turn off and the ODEP circuitry will limit the channel's output drive (see Section 4.2).

### D. IOC Indicators

The yellow IOC (Input/Output Comparator) indicators serve as sensitive distortion indicators to provide *proof of distortion-free performance*. Under normal conditions, the indicators remain off. They light up if the output waveform differs from the input by 0.05% or more. In addition, when the amplifier is running in parallel/mono mode, CH2 IOC stays on under normal conditions (see Section 4.2).

### E. Signal Presence Indicators (SPI)

The signal presence indicators flash synchronously with the amplifier's audio output, when the output voltage is greater than 34 mV. (see Section 4.2).

### F. Enable Indicator

This indicator lights when the amplifier has been enabled, or turned on, and AC power is available. The enable indicator will dim when the energy saving circuit is activated (see Section 4.2).

### G. Enable Switch

This rocker switch is used to turn the amplifier on, off, and enable the remote feature. When turned on by either the rocker switch or the remote R.S.V.P. module, the output is muted for about four seconds to protect your system from any turn-on transients. Delay times vary slightly from one unit to the next, so there is always a certain amount of "randomness". Turn-on inrush is limited by Soft-Start circuitry, so Com-Tech amplifiers never need a power sequencer. (To change the turn-on delay time, contact Crown's Technical Support Group.)

### H. Power Cord

All 120 VAC, 60 Hz North American units have a NEMA 5-15P plug with an integral voltage presence lamp. These units include a 16-gauge power cord with each Com-Tech 210 and 410, and a 14-gauge cord with each Com-Tech 810 and 1610. Other units have an appropriate power cord and plug. All Com-Tech "10" Series amps utilize a convenient 3-foot-long power cord. **To meet full regulatory compliance, these cords must be plugged into a local, cabinet mounted, commercial grade electrical outlet box. "Extension" cords are not recommended or adequate.** Refer to Section 7 for more information on power usage.

### I. Reset Switch

This reset switch is used to reset the circuit breaker that protects the power supplies from overload (see Sections 4.3.4 and 4.4).

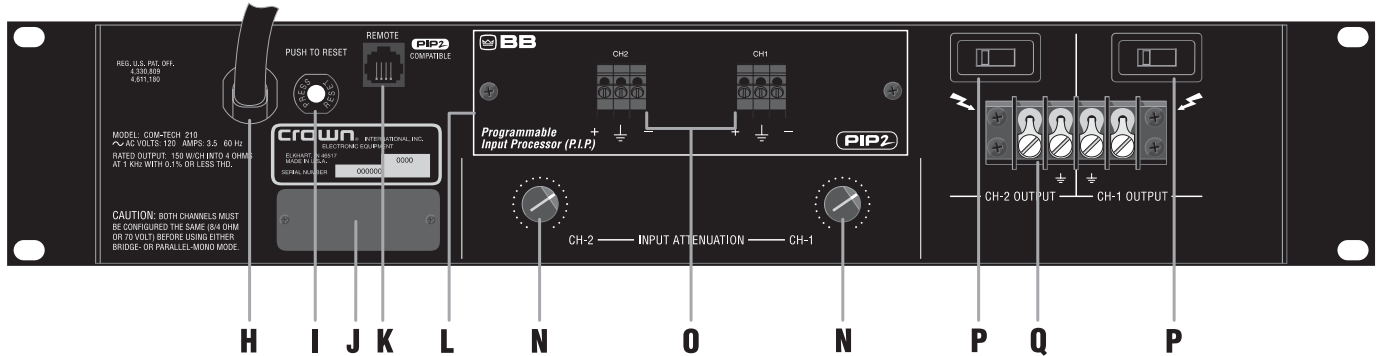

Fig. 2.2 Rear Facilities  
(Domestic Model Shown)

### J. Dual/Mono Switch

For 8- and 4-ohm operation, remove the cover plate, if so equipped, then slide this switch to the center for Dual (two-channel) mode, to the left for Parallel-Mono mode or to the right for Bridge-Mono mode.



**WARNING: Do not change this switch unless the amplifier is turned off. Do NOT use the Bridge-Mono or Parallel-Mono modes unless both output mode switches (O) are set the same.** Also, be sure to follow the installation requirements for each mode (see Section 3.3.1).

### K. Remote Input

For remote operation, an RJ11 jack is used to connect the amplifier to the optional R.S.V.P. (Remote Switching Voltage Provider) module. Do not connect to phone line.

### L. PIP Module

The standard PIP2-BB is included with your amplifier. It provides barrier block input connectors equipped with test points for your DVM. Other PIP modules can be used in place of the PIP2-BB to provide additional features that customize the amplifier for different applications. First generation PIPs require the “PIP2 Adapter” for accessory connectivity (see Section 8 for available PIP modules).

### M. Input Sensitivity Switch (not shown)

The three-position Input Sensitivity Switch located inside the amplifier is accessed by removing the PIP module. It is set at the factory to 0.775 volts for maximum average power (1 kHz power into 8 ohms). It can

also be set to 0.775 volts for 1 kHz output in 70-volt mode, or an overall voltage gain of 26 dB (see Section 4.4).

### N. Input Attenuation Controls

Each channel's output level can be adjusted accurately using these 21-position detented controls on the back panel. A Lexan cover is also included that can be used to discourage tampering (see Section 4.4).

### O. Balanced Barrier Block Inputs

The PIP2-BB is included in the standard configuration. It provides a balanced barrier block with three terminals for each input channel, **as well as test points for a DVM.** (XLR connectors are also available—see Section 8.1.)

### P. Output Mode Switches

The output mode switches are used to configure each channel independently for either 8/4-ohm loads or 70-volt (“constant voltage”) lines.

**WARNING: Do not change these switches unless the amplifier is off. Do NOT use the Bridge-Mono or Parallel-Mono modes unless these switches are set the same.** Also, be sure to follow the special installation requirements for each mode (see Section 3.3.1).



### Q. Output Barrier Block

A barrier block with four terminals is provided for output connection. Output wiring will vary depending on the selected dual/mono mode and whether 70-volt output will be used (see Section 3.3.1).

### 3 Installation

This section covers basic Com-Tech installation procedures. **All Com-Tech amplifiers are intended for rack mount installations using a commercial 19-inch (48.3-cm) EIA rack standard metal cabinet wired with a commercial grade electrical outlet box and receptacles. All Com-Tech Amplifiers utilize a convenient 3-foot long (0.9-m) power cord for such installations.**

#### 3.1 Mounting

Com-Tech amplifiers are designed for standard 19-inch (48.3-cm) rack mounting or stacking without a cabinet. In a rack, it is best to mount units directly on top of each other. This provides the most efficient air flow and support. If the rack will be transported, we recommend that you fasten the amplifier's back panel securely to the rack to help support the unit's weight.

All Com-Tech amplifiers are 19 inches (48.3 cm) wide, 16 inches (40.6 cm) deep, and 0.25 inches (0.6 cm) in front of the mounting surface. As you can see in Figure 3.1, Com-Tech amplifiers vary in their vertical dimensions. Figure 3.1 labels the different heights as A, B and C. These letters correspond to the list that follows showing *Com-Tech* models and their vertical dimen-

sions.

Height A: 3.5 inches (8.9 cm)  
 Models: Com-Tech 210 (All)  
 Com-Tech 410 (North American)

Height B: 5.25 inches (13.3 cm)  
 Models: Com-Tech 410 (100/120 VAC, 50/60 Hz)  
 Com-Tech 410 (220/240 VAC, 50/60 Hz)  
 Com-Tech 810 (All)

Height C: 7 inches (17.8 cm)  
 Model: Com-Tech 1610 (All)

#### 3.2 Cooling

It is important to understand cooling considerations when installing a Com-Tech amplifier. First, never block the amplifier's front or side air vents. This can cause poor air flow and may result in overheating. If the amplifier is rack-mounted, its sides should be at least 2 inches (5 cm) away from the cabinet (see Figure 3.2). Also, open spaces in the front of the rack should be covered with blank panels to prevent improper air flow. Otherwise, heated air from the side exhaust vents can be drawn into the front air intake which may greatly reduce the cooling system's effectiveness.

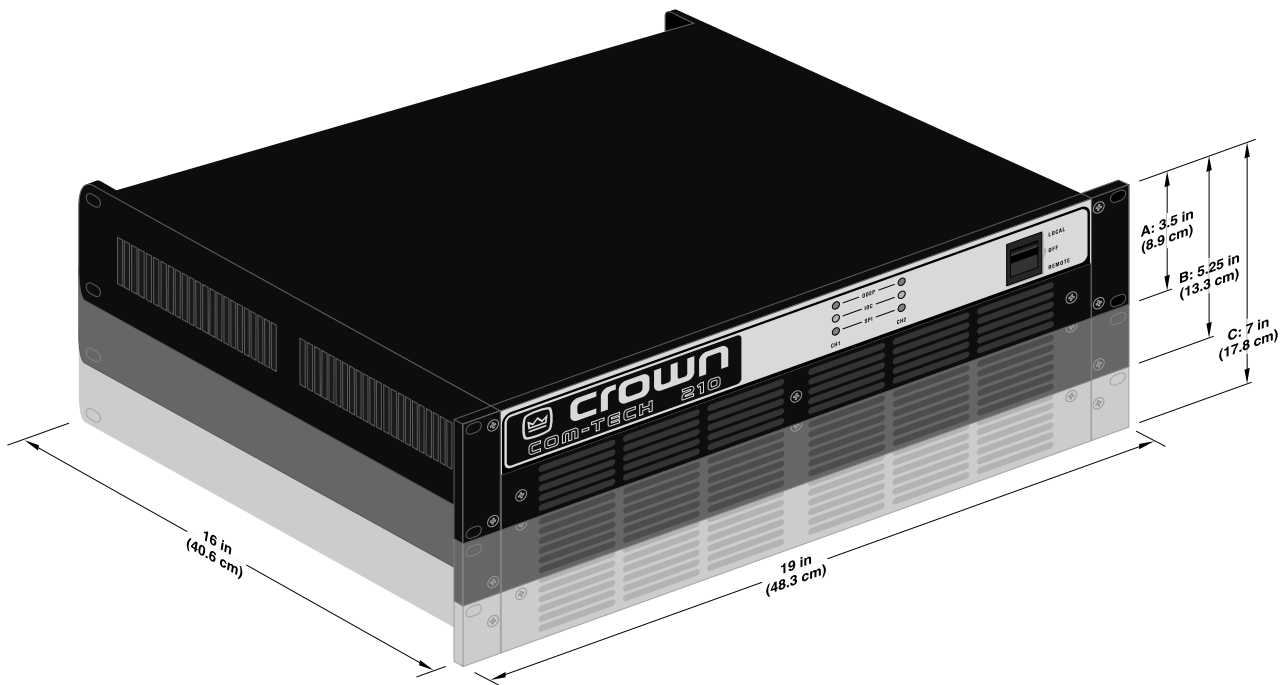

Fig. 3.1 Mounting Dimensions

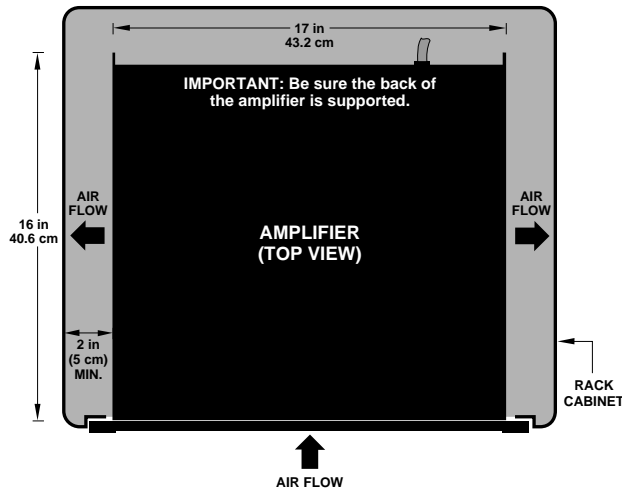

Fig. 3.2 Top View of a Rack-Mounted Unit

The air flow requirement for a Com-Tech amplifier depends on many things, but the most important factor is average output power. Air flow requirements increase as output power increases, so anything that affects output power also affects the required air flow.

Average output power is mainly affected by three things: (1) duty cycle of the input signal, (2) load impedance, and (3) rated output power. First, as the duty cycle of the input signal increases, the average output power level increases. For example, the amplifier will need more air flow with a rock 'n' roll input signal than with infrequent paging. Second, as the load impedance of a connected loudspeaker gets smaller, more current will flow through the load which effectively increases output power. This means you can expect the amplifier to require more air flow with a 4-ohm load than with an 8-ohm load. Finally, an amplifier that is rated for higher power output is usually used at higher average output levels. So a Com-Tech 1610 delivering full output will require more air flow than a Com-Tech 210. These relationships and the resulting thermal dissipation levels are defined mathematically in Section 7.

### 3.2.1 Cooling for Units without Internal Fans

All units have a continuously variable on-demand cooling fan except for the North American Com-Tech 210. Forced-air cooling may not be needed for applications with a low duty cycle such as paging or background music. This is why the North American Com-Tech 210 is usually provided without a fan.

If you will be using a North American Com-Tech 210 in a high-temperature environment, or at full power for sustained periods, you can anticipate that additional cooling will be needed. It may also be helpful to use the

information in Section 7 to estimate the amplifier's thermal dissipation for your application. In general, a North American Com-Tech 210 that dissipates more than 410 btu (110 kcal) per hour per unit will need additional cooling. If you are not sure, observe the ODEP indicators while the amplifier is operating under worst-case conditions. If the indicators dim, additional cooling is recommended.

There are at least three ways to provide extra cooling for an amplifier that does not have an internal fan. The most effective method is to install an internal fan which is available from Crown as an accessory (refer to subsection 8.3). A cooling fan (part GCT200FAN) kit is available for North American Com-Tech 210s (all other units include a fan). Crown recommends the kit if you will be operating the amplifier at high levels or in high temperatures for long periods. Refer to paragraph 8.3 for more information on the cooling fan kit

A rack-mounted blower or an air conditioner can also be used to provide extra cooling. In some situations, you may find it practical to use these methods without installing a fan in each amplifier. However, we generally recommend that you use the internal fans because they provide the most efficient cooling, and are active only when needed. Amplifiers that already have internal fans can also take advantage of a rack-mounted blower or air conditioner, so these approaches will be discussed in the section that follows.

### 3.2.2 Additional Cooling for Units with Internal Fans

If multiple amplifiers will be operated under demanding conditions (such as driving loads less than 4 ohms), or if air flow through the rack will be restricted, you should verify that the total air flow through the rack will be sufficient. As described in Section 3.2.1, sufficient air flow can be tested in the real world by observing the ODEP indicators while operating under worst-case conditions. If the indicators dim, cooling can be improved by reducing air restrictions, installing a rack-mounted blower, or using an air conditioner.

Many things can cause air flow restrictions, including improper mounting, bunched up power cords, closed rack doors, and clogged dust filters. A Com-Tech amplifier should be mounted in a way that allows sufficient air flow into the front intakes, out the side exhaust vents, and out the back of the rack. If your rack has a front door, it is usually best to leave it open and avoid blocking the air intakes. If this is impossible, supplement the air flow by mounting a grille in the door or with a rack-mounted blower. If you install a grille in the door, we recommend wire grilles instead of perforated panels,

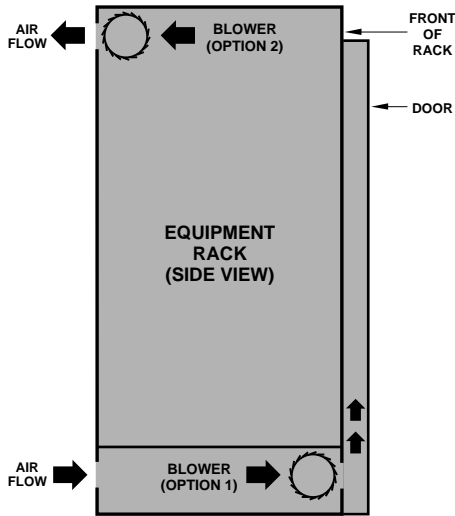

Fig. 3.3 Extra Cooling with a Rack-Mounted Blower

because wire tends to cause less air restriction (perforated panels cause a minimum air restriction of 40%).

A better choice for increasing the air flow behind a rack cabinet door is to use a “squirrel cage” blower. Mount the blower at the bottom of the rack so it blows outside air into the space between the door and the front of the amplifiers, pressurizing the “chimney” behind the door (Figure 3.3, Option 1). The blower should not blow air into or take air out of the space behind the amplifiers. For racks without a front door, you can evacuate the rack by mounting the blower at the top of the rack so that air blows out the back (Figure 3.3, Option 2).

You can estimate the required air flow for a rack by adding together the maximum required air flow ratings of the individual units. The internal fan in a Com-Tech 210 (if installed), 410 and 810 can move up to 35 cubic feet (1 cubic meter) of air per minute, while the internal fan in a Com-Tech 1610 can move up to 65 cubic feet (1.8 cubic meters) per minute. If you mounted one of each Com-Tech model in a rack, worst-case conditions would require 170 cubic feet (4.7 cubic meters) of air flow through the rack every minute (3 x 35 cubic feet + 65 cubic feet = 170 cubic feet).

Air flow restrictions may also result if the air filter becomes clogged. If the air supply is unusually dusty, you can help prevent rapid loading of the unit's air filter by pre-filtering the air using commercial furnace filters. And, when needed, the unit's filter can be cleaned with mild dish detergent and water (see Section 4.6).

The final method for increased cooling is to use air conditioning. Air conditioning is rarely a necessity because internal fans and rack-mounted blowers almost always

provide enough air flow for even the most extreme conditions. Still, air conditioning can help by reducing the temperature of the air circulated through the rack. If you intend to install air conditioning for your amplifiers, you may want to use Section 7 to determine the hourly thermal dissipation of your system.

### 3.3 Wiring

Figures 3.4 through 3.7 show common ways to install a Com-Tech amplifier in a sound system. Input and output terminals are located on the back panel. Please use care when making connections, selecting signal sources and controlling the output level. The load you save may be your own! Crown assumes no liability for damaged loads resulting from careless amplifier use or deliberate overpowering.

**CAUTION: Always disconnect the AC power and turn the level controls off when making or breaking connections.** This is very important when loudspeakers are connected because it reduces the chance of loud blasts that can cause loudspeaker damage. 

#### 3.3.1 Mode of Operation

Proper wiring depends on how you configure your amplifier. First, each output channel can be independently configured to drive step-down transformers in a distributed “constant voltage” loudspeaker system (70-volt mode) or loudspeakers that do not have step-down transformers (8/4-ohm mode). Second, the amplifier can be configured for Dual, Bridge-Mono or Parallel-Mono modes. Various combinations of these modes are possible, so be sure to note any special wiring requirements for the mode you will be using.



70 VOLT

The 70-volt output mode is used to drive constant voltage lines without expensive step-up transformers. Avoiding the use of step-up transformers not only saves money, but it also eliminates the distortion and insertion loss caused by this type of transformer.

Setting up 70-volt mode is easy. Turn off the amplifier, then slide the recessed output mode switches to the 70 VOLT (right) position.

If required by your system design, Com-Tech amplifiers can be configured for either bridge-mono or parallel-mono modes of operation. To switch your amplifier accordingly, start by removing power from the unit. Next,

**!** remove the “Dual-Mono” mode switch cover and set the switch to the desired setting. **Then replace the switch cover plate before restoring power.**

**!** **WARNING: If you have configured the amplifier to produce 100 volts output or greater, your output wiring must conform to the National Electrical Code Class 1 wiring requirements.**

If Bridge-Mono mode is used with 70-volt output, the amplifier will actually deliver 140 volts (more information on this is provided later in this section). To effectively use this mode, you may need to cross-reference power ratings for the step-down transformer taps using Crown’s constant voltage computer (see Section 8.3).

**!** **WARNING: The output mode switches must be set the same (8/4-ohm or 70-volt mode) when operating in Bridge-Mono or Parallel-Mono mode.**

When connecting a 70-volt step-down transformer, do not exceed its power rating. Too much power can saturate a transformer and cause it to appear as a short circuit to the amplifier. If this happens, no damage should occur, but the amplifier may run less efficiently, and the sound quality may be affected.

8/4-ohm mode is commonly used to drive loudspeakers with impedances from 2 to 16 ohms. When using this output mode, appropriate load impedances will depend on the dual/mono mode that you select. The available dual/mono modes (Dual, Bridge-Mono and Parallel-Mono) will be described in sections that follow.

Configuring your amplifier for 8/4-ohm mode is straightforward. Turn off the amplifier and slide the output mode switches to the 8/4 OHM (left) position.

When the amplifier is set up for two-channel (Dual mode) operation, it is possible to configure one output channel for 8/4-ohm operation and the other for 70-volt operation. If you plan to use different output modes like this, the input sensitivity should be set to 0.775-volts for 70-volt output. This will assure you of having enough amplifier gain to reach 70-volt output levels with a .775-volt input signal. The 8/4-ohm channel will need to have its level control turned down so that a .775-volt input signal will not overdrive that channel (see Section 4.4). ALWAYS configure both channels the same when using Bridge-Mono or Parallel-Mono modes.

Because of the way Com-Tech amplifiers are designed, they can be used to directly drive constant voltage lines in 8/4-ohm mode. Being able to use lower constant voltage levels can be very convenient if building codes or other obstacles do not permit higher constant voltage levels. When 8/4-ohm mode is used to drive a distrib-

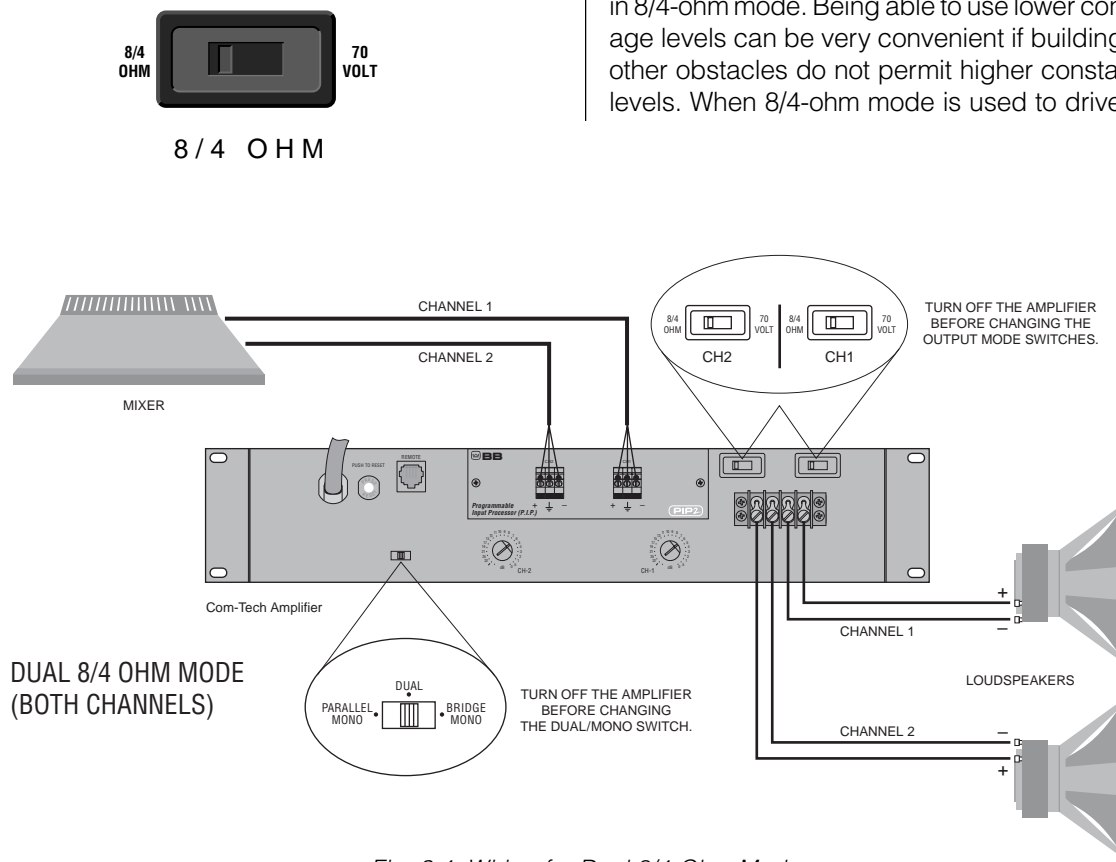

Fig. 3.4 Wiring for Dual 8/4-Ohm Mode

uted loudspeaker system, the constant voltage output varies with the output power rating of the amplifier. With 8/4-ohm output in Dual or Parallel-Mono mode, the Com-Tech 210 can drive a 25-volt line, the Com-Tech 410 can drive a 35-volt line, the Com-Tech 810 can drive a 50-volt line, and the Com-Tech 1610 can drive a 70-volt line. Using Bridge-Mono mode, these voltage levels are doubled for a single channel. Again, to effectively use different constant voltage levels, you may need to cross reference the ratings for the step-down transformers' taps using Crown's constant voltage computer (see Section 8.3).

correct loudspeaker polarity (see Figure 3.4) and be careful not to short the two outputs.

**CAUTION: Never tie an amplifier's outputs together directly while in dual mode. Never parallel them with the output of another amplifier.** Such connections do not result in increased output power, but may cause overheating and premature activation of the protection circuitry.



*Note: To parallel multiple amplifiers for fail-safe redundancy, contact Crown's Technical Support Group.*

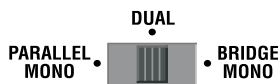

**DUAL**

Dual mode allows each amplifier channel to operate independently like a "dual mono" or stereo amplifier. And if you select both Dual mode and 70-volt output, each output channel can drive a 70-volt line. Installation is intuitive: Input Channel 1 feeds output channel 1, and input Channel 2 feeds output Channel 2.

To put the amplifier into Dual mode, turn it off, slide the dual/mono switch to the DUAL (center) position, and properly connect the output wiring. Be sure to observe

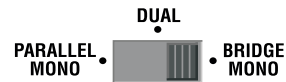

**BRIDGE-MONO**

Bridge-Mono mode is used to drive loads with a total impedance of at least 8 ohms (see *Parallel-Mono* if the load is less than 4 ohms). If Bridge-Mono mode and 70-volt output are used together, twice the normal output voltage is produced from a single channel to drive 140-volt distributed loudspeaker systems. If you will be using 140-volt output, you may need to cross-reference the ratings of the step-down transformer taps with Crown's constant voltage computer (see Section 8.3). If you need a single channel with higher power to drive a 70-volt line, use Parallel-Mono mode.

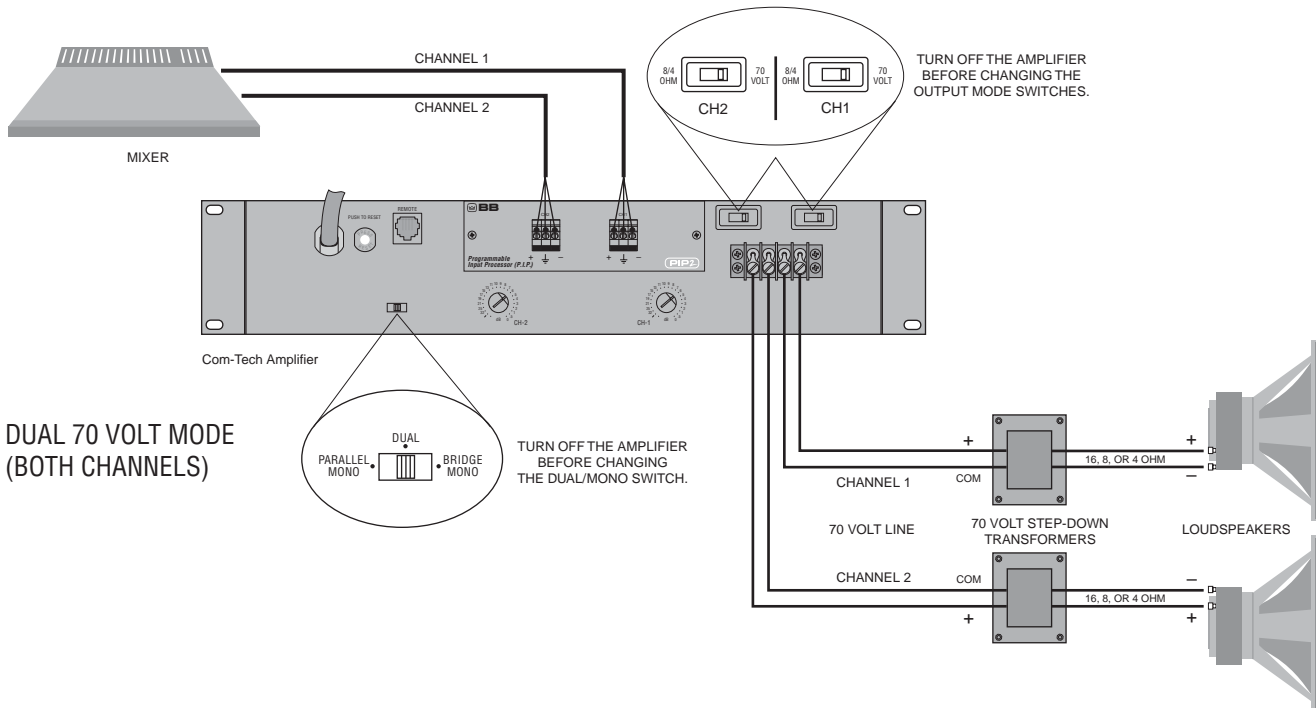

Fig. 3.5 Wiring for Dual 70-Volt Mode



**WARNING:** Both channels must be configured for the same output mode (8/4-ohm or 70-volt) before switching to Bridge-Mono mode.

Bridge-Mono wiring is very different from the other modes and requires special attention. First, turn the amplifier off. Then select Bridge-Mono mode by sliding the dual/mono switch to the BRIDGE MONO (right) position. Both outputs will receive the signal from Channel 1 with the output of Channel 2 inverted so it can be bridged with the Channel 1 output. **DO NOT USE THE CHANNEL 2 INPUT** or the signal level and quality may be greatly degraded. Also, keep the Channel 2 Input Attenuation control turned down completely (counterclockwise).

*Note: The Channel 2 input jack and Input Attenuation control are not defeated in Bridge-Mono mode. A signal feeding Channel 2 will work against the Channel 1 signal, and usually results in distortion and inefficient operation.*

Connect the load across the two positive (+) output terminals (see Figure 3.6 and the middle illustration in Figure 3.7). The positive lead from the load connects to the positive Channel 1 terminal, and the negative (or ground) lead from the load connects to the positive

Channel 2 terminal. Do not connect the output grounds ( $\pm$ ). Also, the load must be balanced (neither side shorted to ground).

**CAUTION:** Connect only balanced equipment (meters, switches, etc.) to the Bridge-Mono output. Both sides of the line must be isolated from the input grounds or oscillations may occur.

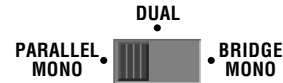

**PARALLEL-MONO**

Parallel-Mono mode is used to drive loads with a total impedance of less than 4 ohms when using 8/4-ohm output mode (see Bridge-Mono if the load is greater than 4 ohms). This mode can also be used to drive a single high-powered 70-volt constant voltage line.

Parallel-Mono installation is very different from the other modes and requires special attention.

**WARNING:** Both channels must be configured for the same output mode (8/4-ohm or 70-volt) before switching to Parallel-Mono mode.

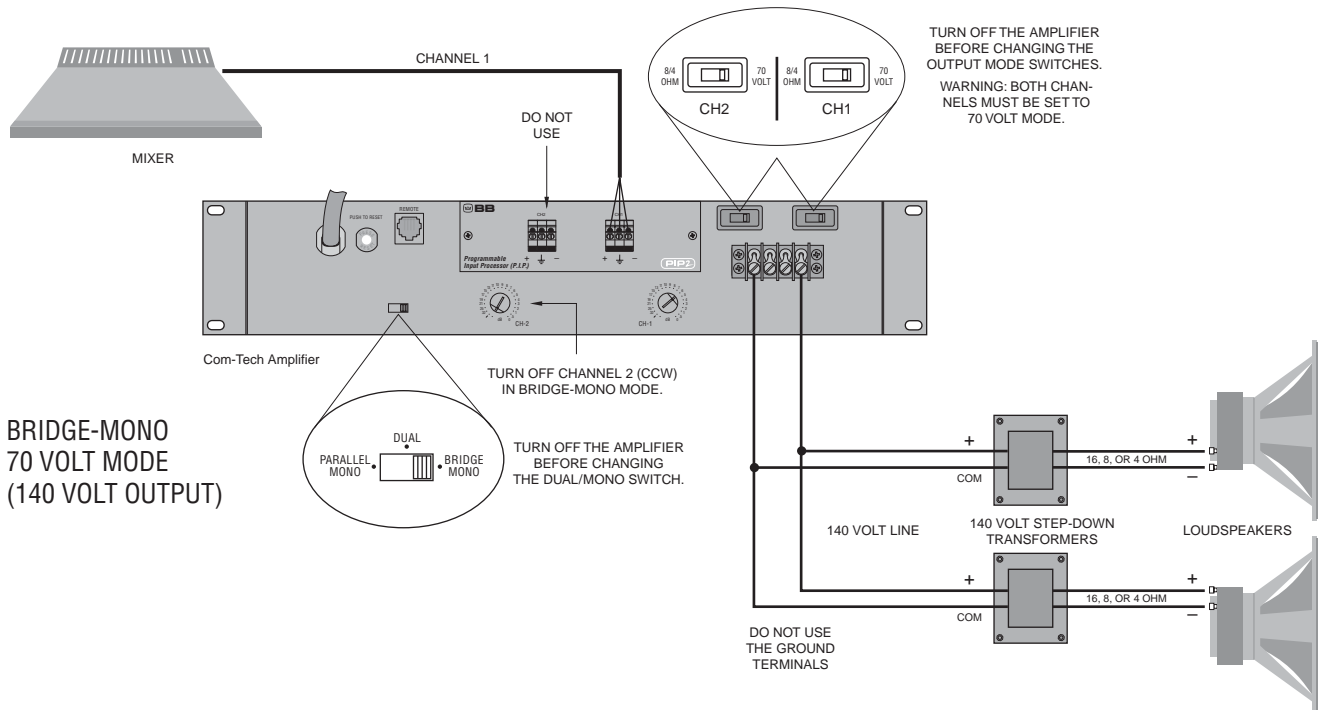

Fig. 3.6 Wiring for Bridge-Mono 70-Volt Mode (140-Volt Output)

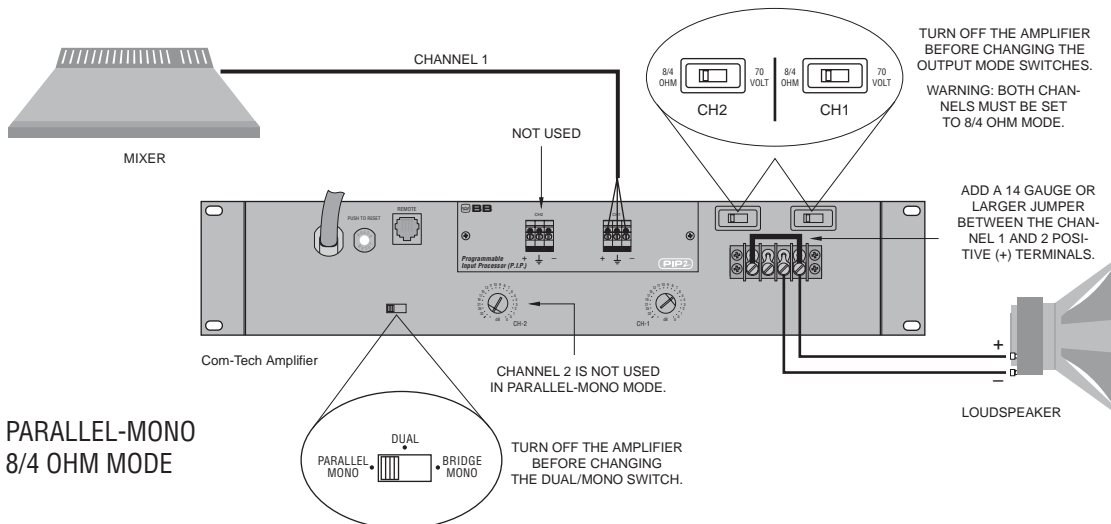
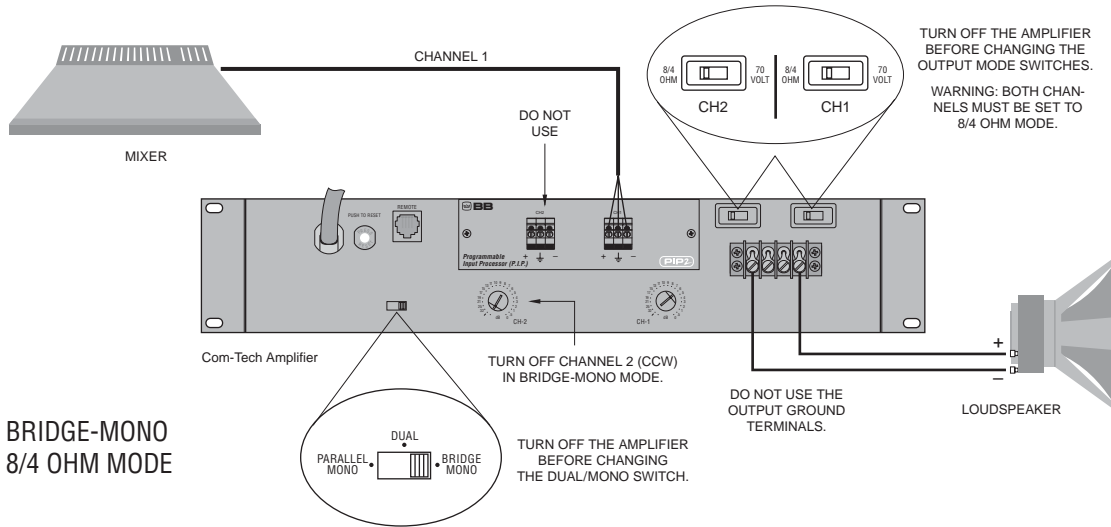
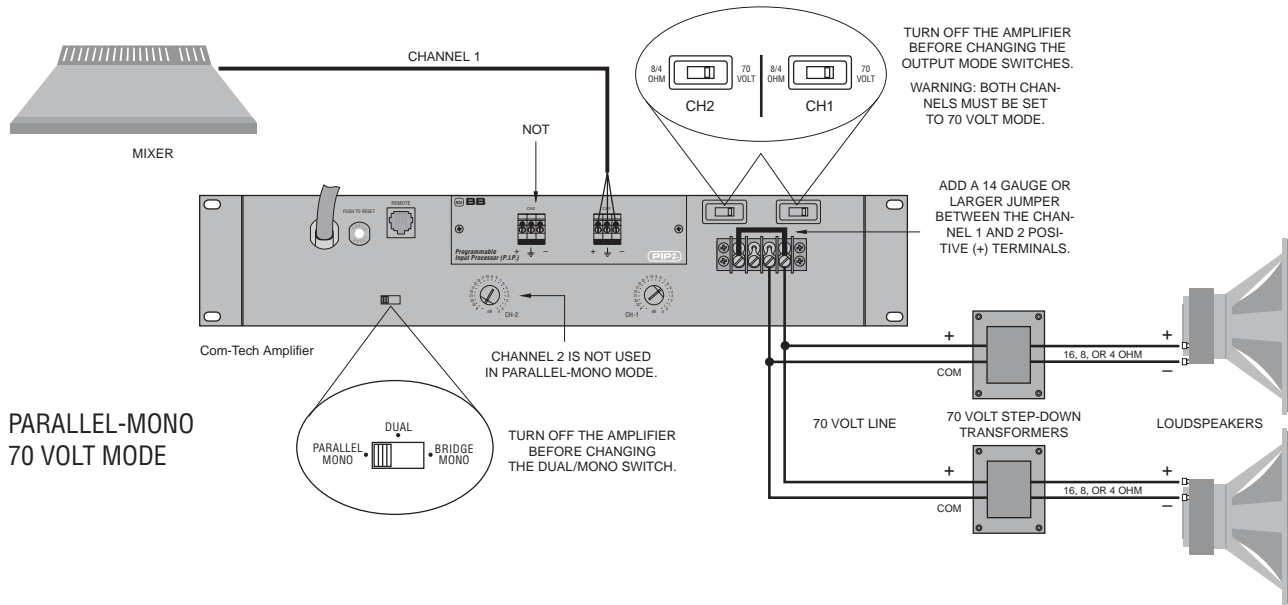

Fig. 3.7 Wiring for Parallel-Mono 70-Volt, Bridge-Mono 8/4-Ohm and Parallel-Mono 8/4-Ohm Modes

To select Parallel-Mono mode, turn off the amplifier and slide the dual/mono switch to the PARALLEL MONO (left) position. Connect the input signal to Channel 1 only. The Channel 2 input jack and Input Attenuation control are bypassed in this mode, so they should not be used.

Connect the load to the Channel 1 output as shown in Figure 3.7 (top and bottom illustrations). The positive lead from the load connects to the positive (+) terminal of Channel 1, and the negative (or ground) lead from the load connects to the ground ( $\perp$ ) terminal of Channel 1. Finally, install a jumper wire of at least 14 gauge between the positive (+) terminals of both channels.\*



**CAUTION:** When Parallel-Mono wiring is installed, do NOT operate in Dual or Bridge-Mono mode until the wiring is removed (especially the jumper wire). Failure to do so will result in high distortion and excessive heating.

### 3.3.2 Audio Input Connection

The balanced inputs have a nominal impedance of 20 k ohms (10 k ohms unbalanced) and will accept the line-level output of most devices. The factory-installed PIP2-BB provides a balanced three-terminal input barrier block for each channel (see Figure 2.2). Optional PIP modules like the PIP2-FXQ, etc., can provide female XLR connectors, phone jacks and phono (RCA) connectors. Various PIPs are also available which provide a wide range of input signal processing features (see Section 8).

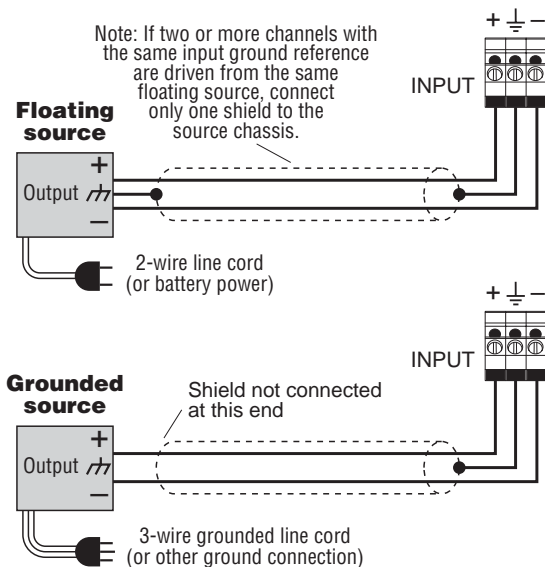

Fig. 3.8 Balanced Input Wiring

Proper input wiring depends on two factors: (1) whether the input signals are balanced or unbalanced, and (2) whether the signal source floats or has a ground reference. The following illustrations provide examples of recommended connection techniques for each type of signal source. (See Figures 3.8 and 3.9.)

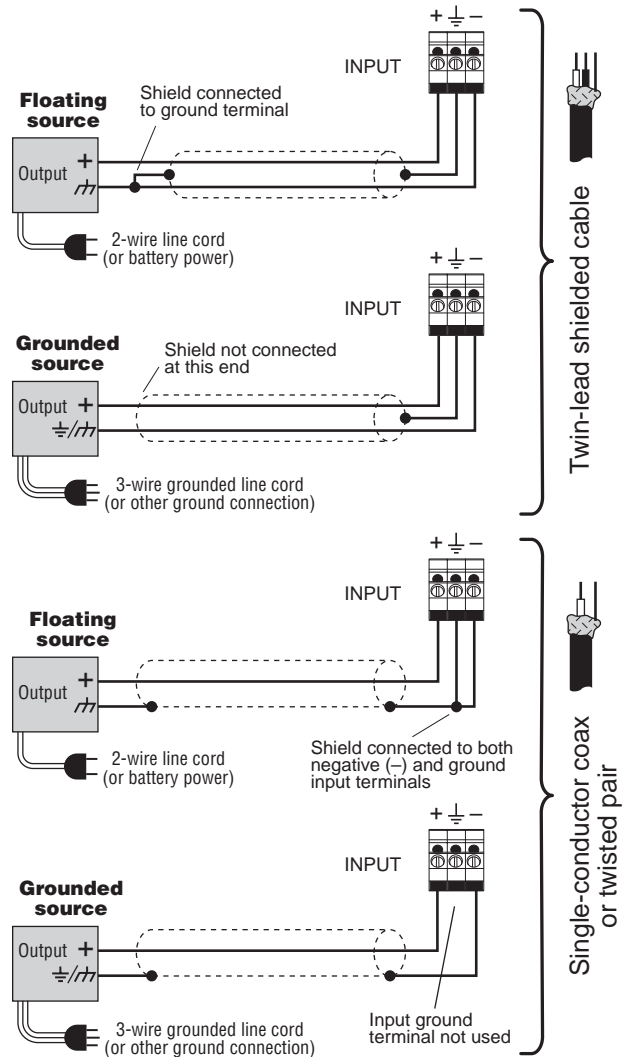

Fig. 3.9 Unbalanced Input Wiring

### SOLVING INPUT PROBLEMS

Sometimes large **subsonic** (sub-audible) frequencies are present in the input signal. These can damage loudspeakers or step-down transformers by overloading or overheating them. To attenuate such frequencies, place a capacitor in series with the input signal line. The graph in Figure 3.11 shows some capacitor values and how they affect frequency response. Use only low-leakage capacitors.

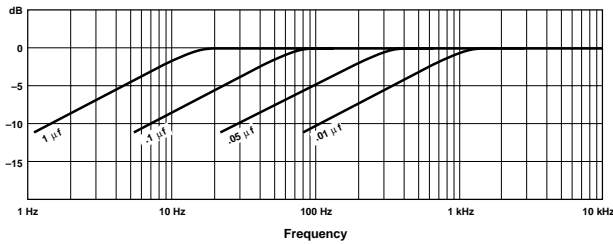

Fig. 3.10 Infrasonic Filter Capacitor Values

Another problem to avoid is large levels of **radio frequencies** or RF in the input signal. Although high RF levels may not pose a threat to the amplifier, they can burn out tweeters or other loads that are sensitive to high frequencies. Extremely high RF levels can also cause your amplifier to prematurely activate its protection circuitry, resulting in inefficient operation. RF can be introduced into a signal by local radio stations and from the bias signal of many tape recorders. To prevent high levels of input RF, install an appropriate low-pass filter in series with the input signal. Some examples of unbalanced wiring for low-pass filters are shown in Figure 3.11.

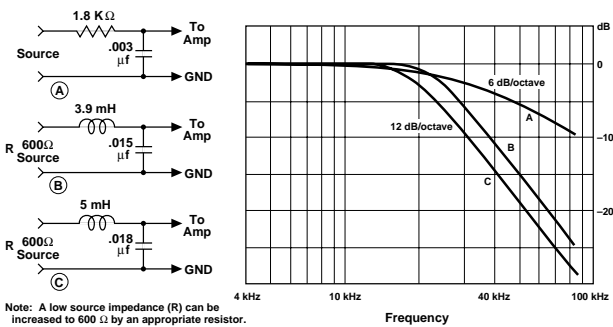

Fig. 3.11 Unbalanced RFI Filters

For balanced input wiring, use an example from Figure 3.12. Filters A, B, and C correspond to the unbalanced filters shown in Figure 3.11. Filter D also incorporates the infrasonic filter in Figure 3.10.

**Tip:** The standard PIP2-BB has space on its circuit board for the addition of input filter circuitry.

A third problem to avoid is **hum**. The two most common sources of hum in an audio system are **inductive coupling** and **ground loops**.

Inductive coupling can occur when input cables are subjected to a magnetic field from a power cord or power transformer. One way to prevent inductive coupling is to lace the input cables together along their length and route them as far away as possible from power transformers and power cords. The use of

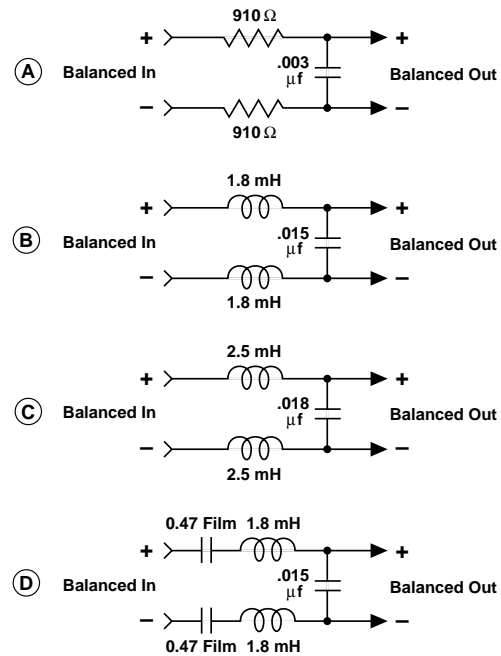

Fig. 3.12 Balanced RFI Filters

shielded pair cable is another effective way to reduce or eliminate hum resulting from inductive coupling.

Ground loops often result when two or more devices are improperly grounded. This causes undesirable stray currents that may produce hum in the output. The best way to avoid ground loops is to ensure that all system devices are plugged into the same power strip. In addition, make sure that all cable shields are grounded at one end only.

### Input Wiring Tips

1. Use only shielded cable. Cables with higher density shields are better. Spiral wrapped shield is not recommended.
2. When using unbalanced lines, keep the cables as short as possible. Avoid cable lengths greater than 10 feet (3 meters).
3. Do not run signal cables together with high-level wiring such as loudspeaker wires or AC cords. This reduces the chance of hum or noise being induced into the input cables.
4. Turn the entire system off before changing connections. Turn level controls down before powering the system back up. Crown is not liable for damage incurred when any transducer or component is overdriven.

### Use Good Connectors

1. To prevent possible short circuits, do not expose the loudspeaker cable connectors.
2. Do not use connectors that might accidentally tie two channels together when making or breaking connections (for example, a standard three-wire stereo phone plug).
3. Connectors that can be plugged into AC power receptacles should never be used.
4. Connectors with low current-carrying capacity should not be used.
5. Connectors with any tendency to short should never be used.

Input and output grounds are sometimes tied together for testing or metering. This can cause **feedback oscillation** from load current in the test loop. In some systems, even the AC power line may provide this feedback path. To avoid this problem, use proper grounding, isolate the inputs and other common AC devices.

### 3.3.3 R.S.V.P. Input Connections

The R.S.V.P. accessory module can control racks of amplifiers at remote locations, providing a system master power on/off switching function. A maximum of 21 amplifiers can be attached to each R.S.V.P. module; however, an unlimited number of R.S.V.P. modules can be slaved together to accommodate any system size.

The power on/off function is controlled from an *IQ-System*<sup>®</sup> AUX or Control Port or from a simple remote contact-closure switch. When under IQ System control, all remote manual-control switches are automatically disabled. This provides priority access to the IQ user and prevents accidental turnoff. For manual switch configuration, two normally-open momentary switches are required: one switch provides the signal to turn the unit on, while the second switch provides the signal to turn the unit off (see Figure 3.13).

### 3.3.4 Output Connection

**WARNING:** Output terminals marked with the ⚠ symbol are dangerous when live. External wiring connected to these terminals requires installation by an instructed person, or should make use of prebuilt wiring and connectors.

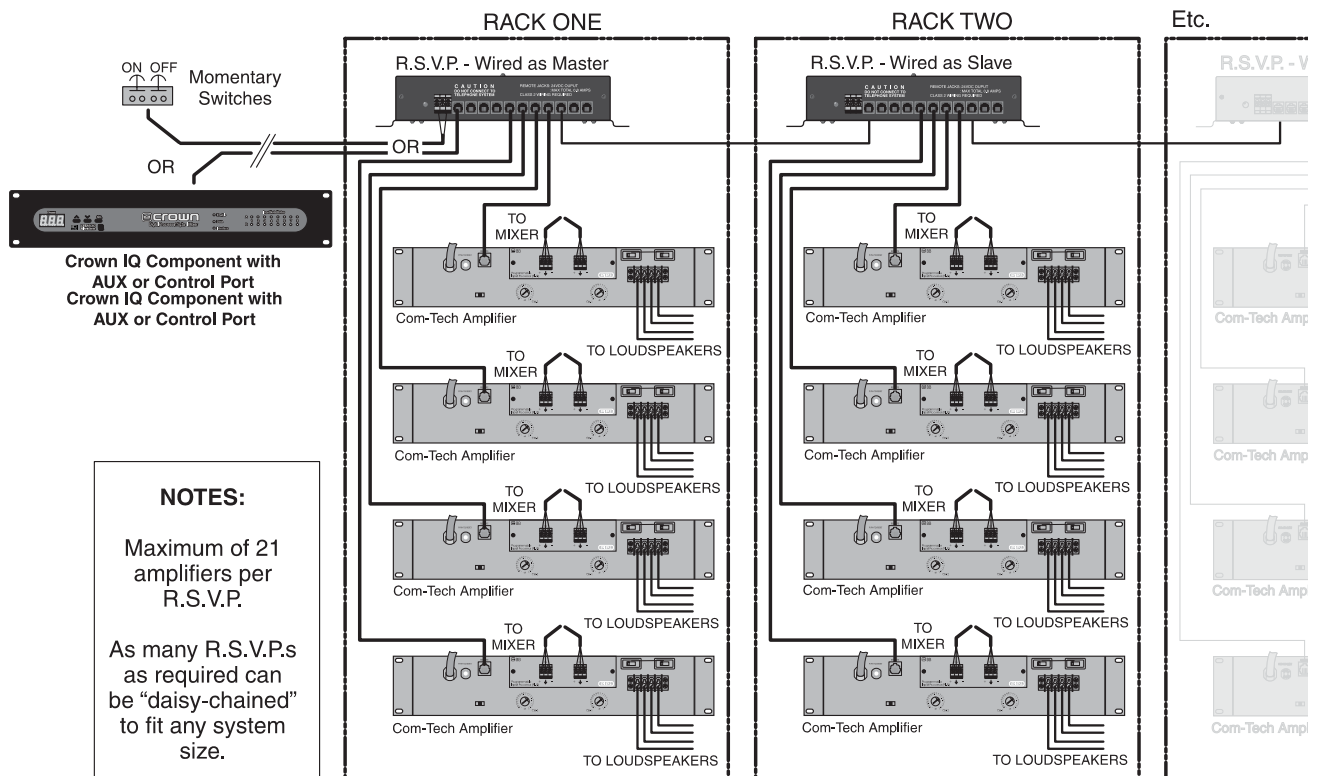

Fig. 3.13 Connecting the RSVP Module

Consider the power handling capacity of your load before connecting it to the amplifier. Crown is not liable for damage incurred at any time due to overpowering. Fusing loudspeaker lines is highly recommended (see Section 3.3.5). Also, please pay close attention to Section 4.1, *Precautions*.

You should always install loudspeaker cables of sufficient gauge (wire thickness) for the length used. The resistance introduced by inadequate output cables will reduce the amplifier's power to and motion control of the loudspeakers. The latter problem occurs because the damping factor decreases as the cable resistance increases. This is very important because the amplifier's excellent damping factor can be easily negated by using insufficient cable.

Use the nomograph in Figure 3.14 and the following procedure to find the recommended wire gauge (AWG or American Wire Gauge) for your system.

1. Note the load resistance of the loudspeakers connected to each channel of the amplifier. If you are using 70-volt output, be sure to determine the load resistance of the step-down transformers (Crown's constant voltage computer can help with this, see Section 8.3). Mark this value on the **Load Resistance** line of the nomograph.
2. Select an acceptable damping factor and mark it on the **Damping Factor** line. Your amplifier can provide an excellent damping factor of 1,000 from 10 to 400 Hz in Stereo mode with an 8-ohm load. In contrast, typical damping factors are 50 or lower. Higher damping factors yield lower distortion and greater motion control over the loudspeakers. A common damping factor for commercial applications is between 50 and 100. Higher damping factors may be desirable for live sound, but long cable lengths often limit the highest damping factor that can be achieved practically. (Under these circumstances, Crown's *IQ System* is often used so amplifiers can be easily monitored and controlled when they are located very near the loudspeakers.) In recording studios and home hi-fi, a damping factor of 500 or more is desirable.
3. Draw a line through the two points with a pencil, and continue until it intersects the **Source Resistance** line.
4. On the **2-Cond. Cable** line, mark the length of the cable run.
5. Draw a pencil line from the mark on the **Source Resistance** line through the mark on the **2-Cond. Cable** line, and on to intersect the **Annealed Copper Wire** line.
6. The required wire gauge for the selected wire length and damping factor is the value on the **Annealed Copper Wire** line. *Note: Wire size increases as the AWG gets smaller.*

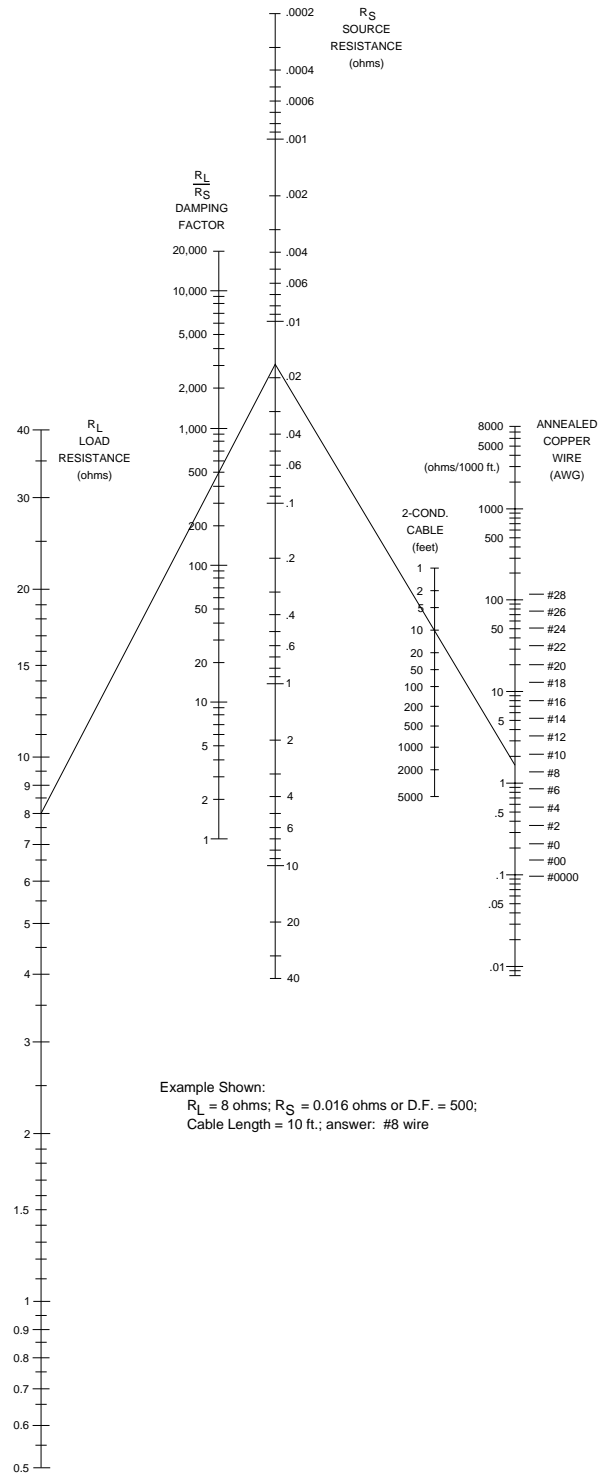

Fig. 3.14 Wire Size Nomograph

- If the size of the cable exceeds what you want to use, (1) find a way to use shorter cables, like using the *IQ System*, (2) settle for a lower damping factor, or (3) use more than one cable for each line. Options 1 and 2 will require the substitution of new values for cable length or damping factor in the nomograph. For option 3, estimate the effective wire gauge by subtracting 3 from the apparent wire gauge every time the number of conductors of equal gauge is doubled. So, if #10 wire is too large, two #13 wires can be substituted, or four #16 wires can be used for the same effect.

### SOLVING OUTPUT PROBLEMS

**High-frequency oscillations** can cause your amplifier to prematurely activate its protection circuitry. The effects of this problem are similar to the RF problems described in Section 3.3.2. To prevent high-frequency oscillations:

- Bundle together each pair of loudspeaker conductors when using long cable runs or when different amplifiers use a common cable tray or jacket. (Do NOT bundle wires from different amplifiers.) This reduces the chance of conductors acting like antennas to transmit or receive the high frequencies that can cause oscillation.
- Avoid using shielded loudspeaker cable.
- Never tie together input and output grounds.
- Never tie together the output of different amplifiers.
- Keep output cables separated from input cables.
- Install a low-pass filter in series with each input (see Section 3.3.2).
- Install the input wiring according to the instructions in Section 3.3.2.

Another problem to avoid is the presence of large **infrasonic currents** when primarily inductive loads are used. Examples of inductive loads are 70-volt transformers and electrostatic loudspeakers.

Inductive loads can appear as a short circuit at low frequencies. This can cause the amplifier to produce large low-frequency currents and activate its protection circuitry. Always take the precaution of installing a high-

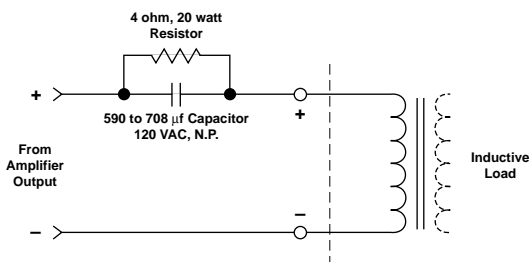

Fig. 3.15 Inductive Load (Transformer) Network

pass filter in series with the amplifier's input when inductive loads are used. A three-pole, 18-dB-per-octave filter with a  $-3$  dB frequency of 50 Hz is recommended (some applications may benefit from an even higher  $-3$  dB frequency). Such a filter is described with infrasonic frequency problems in Section 3.3.2.

Another way to protect inductive loads from large low-frequency currents and prevent the amplifier from prematurely activating its protective systems is to parallel a 590 to 708 µF nonpolarized motor start capacitor and a 4-ohm, 20-watt resistor in series with the amplifier output and the positive (+) transformer lead. This circuit is shown in Figure 3.15. It uses components that are available from most electrical supply stores.

### 3.3.5 Additional Load Protection

Com-Tech amplifiers can generate enormous power output. Using 8/4-ohm output, if your loudspeakers do not have built-in protection from excessive power, it's a good idea to protect them. Loudspeakers are subject to thermal damage from sustained overpowering and mechanical damage from large transient voltages. In both cases, special fuses may be used to protect your loudspeakers, or you may opt for the convenience of a PIP module that provides loudspeaker protection.

Two different types of fuses are required for thermal protection and voltage protection. Slow-blow fuses are usually selected to protect loudspeakers from thermal damage because they are similar to loudspeakers in the way they respond to thermal conditions over time. In contrast, high-speed instrument fuses like the Littelfuse 361100 series are used to protect loudspeakers from large transient voltages. The nomograph in Figure 3.16 can be used to select the properly rated fuse for either type of loudspeaker protection.

There are mainly two different approaches used when installing fuses for loudspeaker protection. A common practice is to put a single fuse in series with the output of each channel. This makes installation easy because there is only one fuse per channel to install, but it can also lead to problems. The biggest disadvantage becomes apparent if the fuse blows because power to all connected loads will be removed.

A better approach is to fuse each driver independently. This allows you to apply the most appropriate protection for the type of driver being used. In general, low-frequency drivers (woofers) are most susceptible to thermal damage and high-frequency drivers (tweeters) are usually damaged by large transient voltages. This means that your loudspeakers will tend to have better protection when the woofers are protected by slow-blow

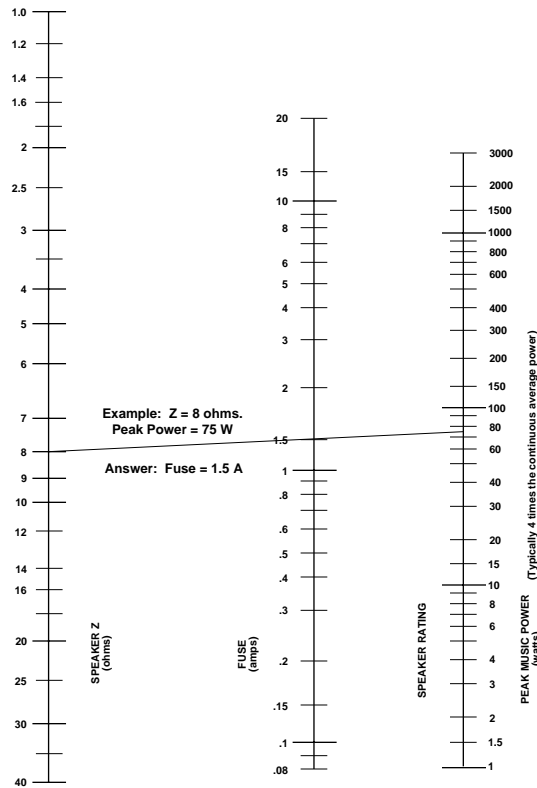

Fig. 3.16 Loudspeaker Fuse Nomograph

fuses and high-frequency drivers are protected by high-speed instrument fuses.

Depending on the application, you may want to use a PIP module to protect your loudspeakers. When properly configured, all PIP modules with signal-driven compression can provide loudspeaker protection. Some of the PIP modules with signal-driven compression include the *P.I.P.-AMCb*, *P.I.P.-EDCb* and *P.I.P.-PA*. While the *P.I.P.-EDCb* is most commonly used for general loudspeaker protection, the *P.I.P.-AMCb* is very popular in systems that require a high-quality crossover, and the *P.I.P.-PA* is the processor of choice for applications that

require a microphone and line level input for each channel. For more information on PIP modules, see Section 8.

### 3.4 AC Power Requirements

All 120 VAC, 60 Hz North American units have a NEMA 5-15 AC plug with an integral voltage presence lamp. These units include a 16 gauge cord with Com-Tech 210s and 410s, and a 14 gauge cord with Com-Tech 810s and 1610s. Other Com-Tech amplifiers are furnished with an appropriate AC cord and plug. All Com-Tech "10" Series amplifiers utilize a convenient, 3-foot-long power cord. **To meet full regulatory system compliance, these cords must be plugged into a local, cabinet mounted, commercial grade electrical outlet box. "Extension" cords are not recommended or adequate.**

Use an isolated wall outlet whenever possible with the correct voltage and adequate current. Voltages greater than 10% above the specified AC mains voltage for the amplifier may damage the  $\pm 15$  volt regulator, filter capacitors and output transistors. See Section 7 for power requirements under various conditions.

All specifications in this manual were measured using 120 VAC, 60 Hz power unless otherwise noted. Specifications are derived using a mains voltage that is accurate to within 0.5% with THD less than 1.0% under all testing conditions. Performance variations can occur at other AC voltages and line frequencies. In addition, line regulation problems will directly affect the output power available from the amplifier.

**"Soft-Start"** inrush current limiting, protects the house circuit breaker when several amps are turned on simultaneously.



## 4 Operation

### 4.1 Precautions

Com-Tech amplifiers are protected from internal and external faults, but you should still take the following precautions for optimum performance and safety:

1. Improper wiring for the Dual, Bridge-Mono and Parallel-Mono modes, as well as the 8/4-ohm and 70-volt output modes can result in serious operating difficulties. Refer Section 3.3.1 for details.



2. **WARNING: Never operate the amplifier in Bridge-Mono or Parallel-Mono mode unless both outputs are configured the same (8/4-ohm or 70-volt).**

3. When driving an inductive load (like a 70-volt step-down transformer) use a high-pass filter or protective network to prevent premature activation of the amplifier's protection circuitry (see Section 3.3.3).



4. **WARNING: Do not change the position of the dual/mono switch or the output mode switches unless the amplifier is first turned off.**



5. **CAUTION: In Parallel-Mono mode, a jumper must be installed between the Channel 1 and 2 positive (+) output terminals. Be sure to remove this jumper for Dual or Bridge-Mono modes, otherwise high distortion and excessive heating will occur.** Check the dual/mono switch on the back panel for proper position.



6. **Turn off the amplifier and unplug it from the AC power before removing a PIP module or before removing the dust filter.**

7. Use care when making connections, selecting signal sources and controlling the output level. The load you save may be your own!

8. Do not connect input and output ground leads together. Ground loops and oscillations may result.

9. Operate the amplifier from AC mains of not more than 10% above or below the selected line voltage and only the specified line frequency.



10. **Never connect the output to a power supply output, battery or power main.** Electrical shock may result.

11. Tampering with the circuitry by unqualified personnel, or making unauthorized circuit changes may be hazardous and invalidates all agency listings.

*Remember: Crown is not liable for damage that results from overdriving other system components.*

### 4.2 Indicators

The front panel of a Com-Tech amplifier has several helpful indicators. The amber **Enable indicator** shows that the amplifier has been turned on (or enabled). It will dim when the unit goes into energy-saving mode. When the Enable indicator is lit, the low-voltage power supply

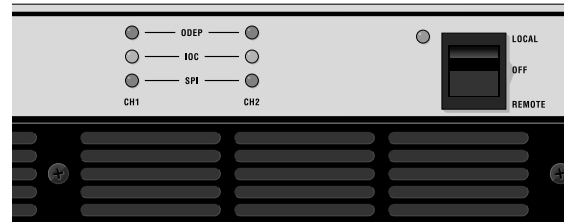

Fig. 4.1 Indicators

is working. It does not indicate the status of the high-voltage power supplies. For example, the Enable indicator will remain lit in the unlikely event that one of the amplifier's protection systems (described in Section 4.3) puts the channel in "standby" mode. The Enable indicator will stay on for all conditions shown in Figure 4.2 except for the first example, "There is no power to the amplifier."

The green **ODEP indicators** confirm the normal operation of Crown's patented Output Device Emulation Protection circuitry. During normal operation, they glow brightly to confirm the presence of reserve thermal-dynamic energy. They dim proportionally as the energy reserve decreases. In the rare event that there is no reserve, they will turn off and ODEP will proportionally limit the drive level of the output stages so the amplifier can continue safe operation even when conditions are severe. (See Section 4.3.1 also.)

An ODEP indicator also turns off if the channel goes into "standby" mode or the amplifier's circuit breaker is tripped. The standby mode is activated if DC or heavy common-mode current is detected at the output, if the transformer thermal protection system is activated, or if a PIP such as the *IQ-PIP-USP2* is used to put the channel into standby. (See Section 4.3.3 and Figure 4.2.)

The yellow **IOC indicators** act as sensitive distortion meters to provide *proof of distortion-free performance*. The IOC (Input/Output Comparator) circuitry compares the incoming signal's waveform to that of the output. Any difference between the two is distortion. The IOC indicators flash if there is a difference of 0.05% or more. It is normal for them to light momentarily when the amplifier is first turned on.\*

The green **Signal Presence Indicators** (SPI) flash synchronously with the output audio. The SPI detector circuit is connected to the amplifier output, so a flashing indicator tells you that there is audio in and out of the amplifier. *Note: The SPI's may not report signal presence if the output signal level is below 34 mV.*

\* Note: When the amplifier's dual/mono switch is moved to the Parallel/Mono position, the Channel 2 IOC indicator will illuminate. This is a normal condition in this configuration.

Indicator Status	Enable Status	Amplifier Condition
ODEP — ● IOC — ● SPI — ●	●	<b>There is no power to the amplifier and all indicators are off, including the Enable light.</b> Possible reasons: (1) The amplifier's Enable switch is off. (2) The amplifier is not plugged into the power receptacle. (3) The AC circuit breaker has been tripped. (4) The amplifier's back panel circuit breaker has been tripped.
ODEP — ● IOC — ☀ SPI — ●	☀	<b>The amplifier channel is in standby mode.</b> Possible reasons: (1) The amplifier has just been turned on and is still in the four second turn-on delay. (2) An IQ PIP Module such as the <i>IQ-PIP-USP2</i> has put the channel in standby. (3) The DC/low-frequency protection circuitry has been activated. (4) The fault protection circuitry has been activated. (5) The transformer thermal protection circuitry has been activated. (6) Amp is in Parallel/Mono if only Channel 2 IOC is illuminated.
ODEP — ☀ IOC — ☀ SPI — ●	◐	<b>The amplifier channel is in standby mode and the energy saving circuit is activated.</b> Possible reasons: (1) An IQ PIP Module such as the <i>IQ-PIP-USP2</i> has put the channel in standby. (2) The fault protection circuitry has been activated. (3) Amp is in Parallel/Mono if only Channel 2 IOC is illuminated.
ODEP — ☀ IOC — ● SPI — ●	☀	<b>Normal operation for a channel with NO audio output.</b> Possible reasons: (1) There is no input signal. (2) The input signal is very low. (3) The channel's Input Attenuation control is turned down.
ODEP — ☀ IOC — ● SPI — ●	◐	<b>Normal operation with energy saving circuit activated.</b>
ODEP — ☀ IOC — ● SPI — ☀	☀	<b>Normal operation for a channel with audio output.</b> The ODEP indicator will remain at full intensity to show that there is reserve thermodynamic energy, and the signal presence indicator (SPI) will flash to show that the channel has audio output.
ODEP — ● IOC — ● SPI — ☀	☀	<b>ODEP limiting is about to activate.</b> Possible reasons: (1) The amplifier's air filters are blocked and need to be cleaned. (2) There is insufficient cooling because of inadequate air flow or air that is too hot. (3) The load impedance for the channel is too low because the output is shorted or the amplifier is driving too many loudspeakers for the selected dual/mono mode. (4) The amplifier channel is continuously being driven to very high output levels.
ODEP — ● IOC — ☀ SPI — ☀	☀	<b>ODEP limiting has been activated.</b> Possible reasons: (1) The amplifier's air filters are blocked and need to be cleaned. (2) There is insufficient cooling because of inadequate air flow or air that is too hot. (3) The load impedance for the channel is too low because the output is shorted or the amplifier is driving too many loudspeakers for the selected dual/mono mode. (4) The amplifier channel is continuously being driven to very high output levels.
ODEP — ☀ IOC — ☀ SPI — ☀	☀	<b>The channel's output is exceeding 0.05% distortion.</b> The input signal level is too high, and IOC is reporting either an input overload or output clipping.

☀ = On   ● = Off   ◐ = Dim

Fig. 4.2 ODEP, IOC and Signal Presence Indicator States

### 4.3 Protection Systems

Com-Tech amplifiers provide extensive protection and diagnostic capabilities. Protection systems include ODEP, “standby” and an AC circuit breaker. These features provide protection under any conditions.

#### 4.3.1 ODEP

Crown invented ODEP to solve two long-standing problems in amplifier design: to prevent amplifier shutdown during demanding operation, and to increase the efficiency of the output circuitry.

To do this, Crown established a rigorous program to measure the *safe operating area* (SOA) of each output device before installing it in an amplifier. Next, Crown designed intelligent circuitry to simulate the instantaneous operating conditions of the output devices. Its name describes what it does: Output Device Emulation Protection or ODEP. In addition to simulating the operating conditions of the output devices, it also compares their operation to their known SOA. If ODEP sees that more power is about to be asked of the output devices than they are capable of delivering under the present

conditions, ODEP immediately limits the drive level until it falls within the SOA. Limiting is proportional and kept to an absolute minimum—only what is required to prevent output device damage.

This level of protection enables Crown to increase output efficiency to never-before-achieved levels while greatly increasing amplifier reliability.

The on-board intelligence is monitored in two ways. First, the front panel ODEP indicators show whether the amplifier is functioning correctly or if ODEP is limiting the drive level. Second, ODEP data is fed to the connector inside the amplifier's back panel PIP compartment so advanced PIP modules like the IQ-PIP-USP2 can use it to monitor and control the amplifier.

This is how ODEP keeps the show going with maximum power and maximum protection at all times.

#### 4.3.2 Standby Mode

An important part of a Com-Tech amplifier's protection systems is standby mode. Standby protects the amplifier during potentially catastrophic conditions. It temporarily removes bias in all four output stages, protecting the amplifier and its loads. This advanced protection implementation, called "**Quad-Mute,**" is new to the Com-Tech series amplifiers. Standby mode can be identified using the indicator table in Figure 4.2.

When you turn on the Enable switch, standby mode is activated to provide **turn-on protection**. This power-up delay lets other system components settle before any signals are amplified, and it provides some "randomness" to the power-up sequence of multiple units reducing the system's current demand during start-up. For further protection, Com-Tech "10" series amplifiers are equipped with a "**Soft-Start**" line current limiter which also reduces turn on inrush.

If dangerous subsonic frequencies or direct current (DC) is detected in the amplifier's output, the unit will activate its **DC/low-frequency protection** circuitry and put the affected channels in standby. This protects the loads and prevents oscillations. The unit resumes normal operation as soon as the amplifier no longer detects dangerous low-frequency or DC output. Although it is extremely unlikely that you will ever activate the amplifier's DC/low-frequency protection system, improper source materials such as subsonic square waves or input overloads that result in excessively clipped input signals can activate this system.

The amplifier's **fault protection** system will put an amplifier channel into standby mode in rare situations

where heavy common-mode current is detected in a channel's output. The amplifier should never output heavy DC current unless its circuitry is damaged in some way, and putting the channel in standby mode helps to prevent further damage.

#### 4.3.3 Transformer Thermal Protection

All Com-Tech amplifiers have transformer thermal protection which protects the power supplies from damage under rare conditions where the transformer temperature rises too high. A thermal switch embedded in the power transformer puts both channels into standby if it detects excessive heat. The switch automatically resets itself as soon as the transformer cools to a safe temperature.

The amplifier's **transformer thermal protection** circuitry is activated in very unusual circumstances where the unit's transformer temperature rises to unsafe levels. Under these abnormal conditions, the amplifier will put both channels into standby mode. In addition, the cooling fan will run at full speed. The amplifier will return to normal operation after the transformer cools to a safe temperature.

If your amplifier is operated within rated conditions, it is extremely unlikely that you will ever see it activate transformer thermal protection. One reason is that ODEP keeps the amplifier working under severe conditions. Even so, higher than rated output levels, excessively low-impedance loads and unreasonably high input signals can generate more heat in the transformer than in the output devices. This can overheat the transformer and activate its protection system.

Com-Tech amplifiers are designed to keep working under conditions where other amplifiers fail. Yet, even when the limits of a Com-Tech are exceeded, it still protects itself—and your investment—from damage.

#### 4.3.4 Circuit Breaker

A circuit breaker is provided to prevent the high-voltage power supplies from drawing excessive current. A reset switch for the circuit breaker is provided on the back panel. The rating of the circuit breaker for each amplifier model and each AC operating voltage is provided with the specifications in Section 6. When operating with rated loads and output levels, this breaker should trip only in the unlikely event of a catastrophic amplifier failure. Other protection systems such as ODEP keep the amplifier safe and operational under most other severe conditions. The breaker can also trip in situations where extremely low-impedance loads and high output levels result in current draw that exceeds the breaker's rating.

Again, this should only be possible when operating *outside rated conditions*, as when the amplifier is used to drive a 1-ohm load, or when an input signal is clipped severely.

#### 4.4 Controls

The **Enable switch** is located on the front panel so you can easily turn the amplifier on and off. If you ever need to make any wiring or installation changes, don't forget to disconnect the power cord. Please follow these steps when first turning on your amplifier:

1. Turn down the level of your audio source. For example, set your mixer's volume to "∞."
2. Turn down the level controls of the amplifier.
3. Turn on the Enable switch. The Enable indicator should glow. During the four second turn-on delay which immediately follows, the indicators will flash as described in Figure 4.1. After the delay, the ODEP indicators should come on with full brilliance and the IOC and Signal Presence Indicators should function normally.
4. After the turn-on delay, turn up the level of your audio source to the desired level.
5. Turn up the Input Attenuation controls on the back panel of the amplifier until the desired loudness or power level is achieved.
6. Turn down the level of your audio source to its normal range.

A 21-position detented **Input Attenuation control** is provided for each channel. For security, the level controls are located on the back panel. To discourage tampering from the rear, a Lexan cover is provided that can be attached to the back panel with the included 1/2-inch 8-32 screws.

Com-Tech amplifiers have a **reset switch** for the AC circuit breaker. If the circuit breaker trips, the Enable indicator turns off. In this situation, turn off the Enable switch and reset the circuit breaker. Then, turn the Enable switch back on. If it trips again or the unit fails to operate properly, contact an authorized service center or Crown's Technical Support Group.

A three-position **input sensitivity switch** is located inside the amplifier's PIP compartment. It is set at the factory to a sensitivity of 0.775-volts (8/4-ohm mode).

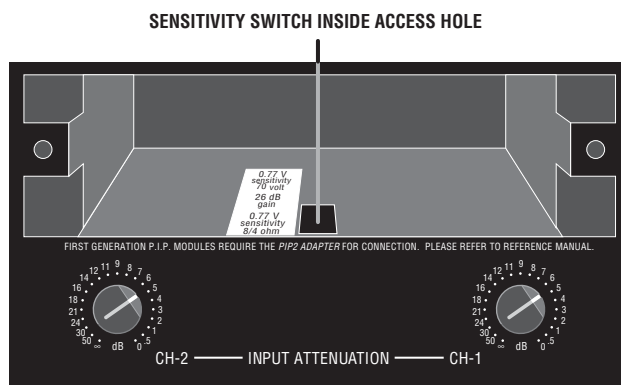

Fig. 4.3 Input Sensitivity Switch

Please notice that there is a separate 0.775-volt position for 70-volt mode. If desired, the sensitivity can be switched to a voltage gain of 26-dB. With 26-dB gain and 70-volt output, the input sensitivity for all models is 3.5 volts. With 26-dB gain and 8/4-ohm output, the input sensitivity varies among the different amplifier models. To generate rated 1-kHz power, the input voltage required is 1.48 volts for the Com-Tech 210, 2.12 volts for the Com-Tech 410, 2.47 volts for the Com-Tech 810, and 3.29 volts for the Com-Tech 1610.

It is also possible to configure the amplifier with one channel set to 8/4-ohm output and the other set to 70-volt. With this configuration, the input sensitivity switch should be set to 0.775 volts (70 volt), and the Input Attenuation control for the 8/4 ohm channel can be adjusted to compensate for the additional gain.

To change the input sensitivity:

1. Turn off the amplifier and disconnect the power cord from the receptacle.
2. Remove the PIP module.
3. Locate the access hole for the Input Sensitivity switch inside the chassis opening (Figure 4.3).  
*Note: The input sensitivity switch is not visible because it is mounted below the hole. Use your little finger to reach it.*
4. Set the switch to the desired position noted on the access hole label.
5. Replace the PIP module and restore power.

## 4.5 Energy Saving Circuit Application

The new CT-10 Series amplifiers incorporate a new feature to significantly decrease the use of energy when the amplifier is idle. The **Energy Saving** circuit allows the amplifier to cut back its energy consumption based on the signal level offered to the inputs. Over time, this circuitry provides the end user better value by saving on air conditioning requirements and utility expenses.

This circuit is normally active at all times. Whenever both input signals drop below an absolute 5 mV at the output connector for 30 minutes, the **Energy Saving** circuit cuts back the amplifier power consumption. As either input signal returns and the output signal rises past the 5 mV threshold, the amplifier power consumption returns to its operating levels.

## 4.6 Filter Cleaning

A dust filter is provided on the amplifier's air intake (Figure 2.1). If this filter becomes clogged, the unit will not cool as efficiently as it should and high heat sink temperatures may produce lower-than-normal output.

Dust filters are not 100% efficient—depending on the local environment, the internal heat sinks of the amplifier will benefit from periodic cleaning by a qualified technician. Internal cleaning information is available from our Technical Support Group.

# 5 Technical Information

## 5.1 Overview

Com-Tech amplifiers incorporate several new technological advancements including real-time computer simulation, low-stress output stages, an advanced heat sink embodiment and the Programmable Input Processor (PIP) expansion system.

Custom circuitry is incorporated to limit temperature and current to safe levels, making it highly reliable and tolerant of faults. Unlike many lesser amplifiers, it can operate at its voltage and current limits without self-destructing.

Real-time computer simulation is used to create an analog of the junction temperature of the output transistors (hereafter referred to as the output devices). The amplifier's output is limited only when the device temperature becomes excessive (and by the minimum amount required). This patented approach called Output Device Emulation Protection (or ODEP) maximizes the available output power and protects against overheating—the major cause of device failure.

The amplifier is protected from all common hazards that plague high-power amplifiers, including shorted, open or mismatched loads; overloaded power supplies; excessive temperature and chain-destruction phenomenon; input overload; high-frequency blowups, internal faults; and input and output DC.

The four-quadrant topology used in a Com-Tech amplifier's output stages is called the *Grounded Bridge*. This patented topology makes full use of the power supply, providing peak-to-peak voltages to the load that are twice the voltage seen by the output devices (see Figure 5.1).

As its name suggests, the *Grounded Bridge* topology is referenced to ground. Composite devices are constructed to function as large NPN and PNP devices to handle currents which exceed the limits of available devices. Each output stage has two composite NPN devices and two composite PNP devices.

The devices connected to the load are referred to as “high-side NPN and PNP” and the devices connected to ground are referred to as “low-side NPN and PNP.” Positive current is delivered to the load by increasing conductance simultaneously in the high-side NPN and low-side PNP stage, while synchronously decreasing conductance of the high-side PNP and low-side NPN.

The two channels may be used together to double the voltage (Bridge-Mono) or current (Parallel-Mono) presented to the load. This feature gives you flexibility to maximize power available to the load.

A wide bandwidth, multiloop design is used for state-of-the-art compensation. This produces ideal behavior and results in ultra-low distortion values.

Aluminum extrusions have been widely used for heat sinks in power amplifiers due to their low cost and reasonable performance. However, measured on a watts-per-pound or watts-per-volume basis, the extrusion technology doesn't perform nearly as well as the heat exchangers developed for Com-Tech amplifiers.

Our heat exchangers are fabricated from custom convoluted fin stock that provides an extremely high ratio of area to volume, and area to weight. All power devices are mounted directly to massive heat spreaders that are electrically at the Vcc potential. Electrifying the heat spreaders improves thermal performance by eliminating an insulating interface underneath each power device. The chassis itself is used as part of the thermal circuit to maximize utilization of the available cooling resources.

### 5.2 Circuit Theory

Each channel is powered by its own power transformer winding. Both channels share a common low-voltage supply. The secondary output of the power transformer is full-wave rectified and is filtered by a large computer grade capacitor. A thermal switch embedded in the power transformer protects it from overheating.

The low-voltage winding in the power transformer is rectified to generate an unregulated 24 volts. Monolithic regulators provide a regulated  $\pm 15$  volts.

#### 5.2.1 Dual Operation

For simplicity, the discussion of Dual operation will refer to one channel only. Mono operation will be discussed in Sections 5.2.2 and 5.2.3. Please refer to the block diagram in Figure 5.1.

The signal at the PIP barrier block passes directly into the balanced input stage. The balanced input stage causes balanced to single-ended conversion using a difference amplifier. Next the variable gain stage amplifies or attenuates the signal. The gain of this stage is set by the position of the input sensitivity switch and the back panel Input Attenuation control. The error amp amplifies the difference between the output signal and the input signal from the gain pot, and drives the voltage translator stage.

From the error amp, the voltage translator stage channels the signal to the Last Voltage Amplifiers (LVAs), depending on the signal polarity. The +LVA and the -LVA, with their push-pull effect through the bias servo, and drive the fully complementary output stage.

The bias servo is thermally coupled to the heat sink, and sets the quiescent bias current in the output stage to lower the distortion in the crossover region of the output signal.

With the voltage swing provided by the LVAs, the signal then gains current amplification through the Darlington emitter-follower output stage.

The bridge-balanced circuit receives a signal from the output of the amplifier and detects the difference between it and the signal at the Vcc supply. The bridge-balanced circuit then develops a voltage to drive the bridge-balanced output stage. This results in the Vcc supply having exactly one half of the output voltage added to the quiescent voltage.

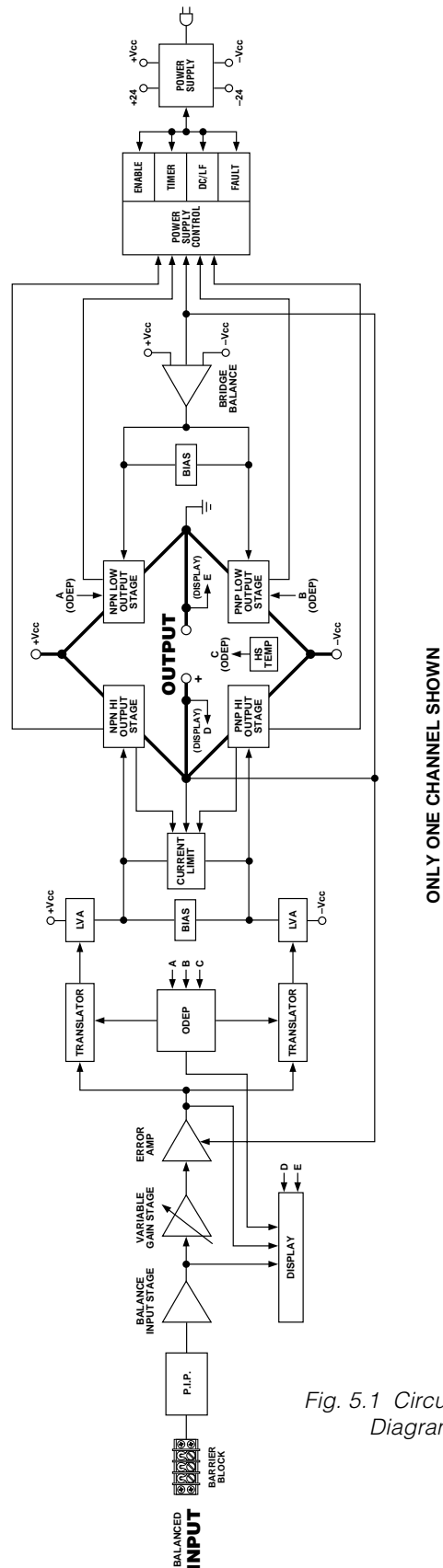

Fig. 5.1 Circuit Block Diagram

The protection mechanisms that affect the signal path are implemented to protect the amplifier under real-world conditions. These conditions are high instantaneous current, excessive temperature, and output device operation outside safe conditions.

Two transistors act as a conventional current limiter, sensing current in the output stage. If current exceeds safe levels, the limiters remove the drive from the LVAs, limiting current in the output stage to a safe level.

To further protect the output stages, the patented ODEP circuitry is used. It produces an analog output proportional to the always changing *safe operating area* of the output transistor. This output controls the translator stage previously mentioned, removing any further drive that may exceed the *safe operating area* of the output stage.

A thermal sensor supplies the ODEP circuits with information on the operating temperature of the heat sink on which the output devices are mounted.

Should the amplifier fail in a way that would cause DC across the output lead, the DC protection circuit senses this on the negative feedback loop and shuts down the output stages until the DC is removed.

### 5.2.2 Bridge-Mono Operation

By setting the dual/mono switch on the back panel to Bridge-Mono, the user can convert the Com-Tech into a bridge-mono amplifier. With a signal applied to the Channel 1 input jack, and the load between the positive (+) output terminals on the back panel, twice the voltage can be output.

The Channel 1 output feeds the Channel 2 error amp. Because there is a net inversion, the Channel 2 output is out of polarity with Channel 1. This produces twice as much voltage across the load. Each of the channel's protection mechanisms work independently if a fault occurs.

### 5.2.3 Parallel-Mono Operation

With the dual/mono switch set to Parallel-Mono, the output of Channel 2 is paralleled with the output of Channel 1. A suitable high current-handling jumper must be connected across the positive (+) output terminals to gain the benefits of this operating mode.

The signal path for Channel 1 is the same as previously discussed, except that Channel 1 also drives the output stage of Channel 2. The Channel 2 balanced input, error amp, translators and LVAs are disconnected and no longer control the Channel 2 output stage. The Channel 2 output stage and protection mechanisms are also coupled through S1 and function as one.\*

In Parallel-Mono mode, twice the current of a single channel is available. Because the Channel 2 ODEP circuit is coupled to Channel 1, you have added protection if a fault occurs in the Channel 2 output stage. The Channel 2 ODEP circuit limits the output of both output stages by removing the drive from the Channel 1 translator stages.

---

\* Note: When the amplifier's dual/mono switch is moved to the Parallel/Mono position, the Channel 2 IOC indicator will illuminate. This is a normal condition in this configuration.

## 6 Specifications

The following specifications apply to all models in Dual mode with 8-ohm loads and an input sensitivity of 26 dB unless otherwise specified.

**MAP at 1 kHz:** This term refers to maximum average power in watts at 1 kHz with 0.1% THD.

**Full Bandwidth Power:** This term refers to maximum average power in watts from 20 Hz to 20 kHz with 0.1% THD.

**120 VAC, 60 Hz Units:** These North American units have dedicated transformers for 120 VAC, 60 Hz power mains.

**100/120 VAC Units:** These units have two-tap transformers that accept a 50- or 60-Hz AC line, and can be configured for 100- or 120-VAC mains.

**220/240 VAC Units:** These units have two-tap transformers that accept a 50- or 60-Hz AC line, and can be configured for 220 or 240 VAC.

### Performance

**Frequency Response:**  $\pm 0.1$  dB from 20 Hz to 20 kHz at 1 watt (see Figure 6.9).

**Phase Response:**  $\pm 10$  degrees from 10 Hz to 20 kHz at 1 watt (see Figure 6.12).

**Hum and Noise:** A-weighted, 105 dB below full bandwidth power; No weighting, 100 dB below full bandwidth power.

**Total Harmonic Distortion (THD):** Less than 0.05% at full power from 20 Hz to 1 kHz increasing linearly to less than 0.1% at 20 kHz.

**Intermodulation Distortion (IMD):** (60 Hz and 7 kHz 4:1) Less than 0.05% from -35 dB to full power bandwidth.

**Damping Factor:** Greater than 1000 from 10 Hz to 400 Hz (see Figure 6.10).

**Crosstalk:** See Figure 6.13.

**Common Mode Rejection Ratio (CMRR):** Better than 70 dB.

**Slew Rate:** Greater than 17 volts per microsecond.

**Voltage Gain:** (At the maximum level setting) 20:1  $\pm 6\%$  or 26 dB  $\pm 0.5$  dB. 90:1  $\pm 6\%$  or 39 dB  $\pm 0.5$  dB with the input sensitivity set to 0.775 volts for 70 volt output. The following voltage gain specifications are for units with the input sensitivity set to 0.775 volts for 8/4 ohm output:

Com-Tech 210: 38:1  $\pm 6\%$  or 32 dB  $\pm 0.5$  dB.

Com-Tech 410: 55:1  $\pm 6\%$  or 35 dB  $\pm 0.5$  dB.

Com-Tech 810: 64:1  $\pm 6\%$  or 36 dB  $\pm 0.5$  dB.

Com-Tech 1610: 85:1  $\pm 6\%$  or 39 dB  $\pm 0.5$  dB.

### Power

**Output Power:** See the Minimum Guaranteed Power tables in Figures 6.1-4 for the output power specifications under a variety of conditions.

*It is extremely important to supply the amplifier with adequate AC power. Power amplifiers cannot add power—they need the required voltage and current to deliver the undistorted rated wattages you expect.*

**Load Impedance:** Safe with all types of loads. With 8/4 ohm output, all Com-Techs are rated for 4 to 8 ohms in Dual mode, 8 to 16 ohms in Bridge-Mono mode, and 2 to 4 ohms in Parallel-Mono mode. With 70 volt output, rated loads vary among the different models for each dual/mono mode (see the power matrices that follow).

**AC Power Requirements:** All units require less than 90 watts at idle. See Section 7 for detailed information on AC power requirements and thermal dissipation.

**Low-Voltage Power Supply:**  $\pm 15$  VDC regulated supplies are provided by a winding on the power transformer.

**Power Cord:** An appropriate AC line cord is provided with a nominal cable length of 3 feet (see Section 2).

### Controls

**Enable:** A front panel rocker switch used to turn the amplifier on and off, and enable the remote feature.

**Input Attenuation:** A detented 21-position back panel Input Attenuation control for each channel.

**Output Mode:** A back panel switch for each channel used to select 8/4-ohm or 70-volt output.

**Dual/Mono:** A 3-position back panel switch used to select Dual, Bridge-Mono or Parallel-Mono operation.

**Reset:** A back panel push button used to reset the amplifier's AC mains breaker.

**Input Sensitivity:** A three-position switch inside the PIP compartment used to select an input sensitivity for both channels: 0.775 volts for MAP at 1 kHz in 8/4-ohm mode, 0.775 volts for MAP at 1 kHz in 70-volt mode, or a voltage gain of 26 dB (Section 4.4).



## Indicators

**Enable:** This amber indicator shows the on/off status of the unit's low-voltage power supply and the activation of the energy-saving mode.

**SPI (Signal Presence Indicator):** Each channel has a green indicator that flashes to show audio output.

**IOC (Input/Output Comparator):** Each channel has a yellow indicator that flashes if the output waveform differs from the input waveform by 0.05% or more. The LEDs act as sensitive distortion indicators to provide *proof of distortion-free performance*.

**ODEP (Output Device Emulation Protection):** Each channel has a green multifunction indicator that shows the channel's reserve energy status. Normally, the LEDs are brightly lit to show that reserve energy is available. In the rare event that a channel has no reserve, its indicator will dim in proportion to ODEP limiting. An ODEP indicator may also turn off under other more unusual circumstances (see Section 4.2).

## Input/Output

**Input Connector:** A barrier block on the standard PIP2-BB with three-terminal balanced connections for input to each channel and test points for a DVM.

**Input Impedance:** Nominally 20 K ohms, balanced. Nominally 10 K ohms, unbalanced.

**Input Sensitivity:** Settings include 0.775 volts for 8/4-ohm output, 0.775 volts for 70-volt output, and a voltage gain of 26 dB.

**Output Connector:** A back panel barrier block with two-terminal connections for each output channel.

**Output Impedance:** Less than 10 milliohms in series with less than 2 microhenries (see Figure 6.11).

**DC Output Offset:** Less than  $\pm 10$  millivolts.

**RSVP:** An RJ11 modular connector on the back panel interfaces with an RSVP to provide remote control of a large number of amplifier power on/off functions.

## Output Signal

**Dual:** Unbalanced, two-channel.

**Bridge-Mono:** Balanced, single-channel. Channel 1 controls are active; Channel 2 should be turned down.

**Parallel-Mono:** Unbalanced, single-channel. Channel 1 controls are active; Channel 2 is bypassed.

## Protection

Com-Tech amplifiers are protected against shorted, open or mismatched loads; overloaded power supplies; excessive temperature, chain destruction phenomena, input overload damage and high-frequency blowups. They also protect loudspeakers from input/output DC and turn-on/turn-off transients.

If unreasonable operating conditions occur, the patented ODEP circuitry proportionally limits the drive level to protect the output devices, particularly in the case of elevated temperature. Transformer overheating results in a temporary shutdown of both channels. The transformer automatically resets itself when it has cooled to a safe temperature. Controlled slew rate voltage amplifiers protect against RF burnouts, and input overload protection is provided by current-limiting resistance at the input.

**Turn On:** The four-second turn on delay prevents dangerous turn-on transients. "Soft-start" circuitry provides low inrush so power sequencers are rarely needed with multiple units. *Note: The turn-on delay time may be changed. Contact Crown's Technical Support Group for details.*

**Circuit Breaker:** Circuit breaker current ratings vary based on the Com-Tech model and AC mains voltage.

All 100/120 VAC Units:

Com-Tech 210: 8 amperes.

Com-Tech 410: 12 amperes.

Com-Tech 810: 20 amperes.

Com-Tech 1610: 30 amperes.

All 220/240 VAC Units:

Com-Tech 210: 4 amperes.

Com-Tech 410: 6 amperes.

Com-Tech 810: 10 amperes.

Com-Tech 1610: 20 amperes.

## Construction

Durable black powdercoat finish on the steel chassis, front panel Lexan overlay, and specially-designed flow-through ventilation from front to side panels.

**Cooling:** Internal heat exchangers with on-demand forced air cooling (fan is optional for the North American Com-Tech 210; see Sections 3.2.1 and 8.2).

**Dimensions:** 19 inch (48.3 cm) standard rack mount width (EIA RS-310-B), 16 inch (40.6 cm) depth behind mounting surface, and 0.25 inches (0.6 cm) in front of mounting surface. Amplifier height varies among the available models and with different AC power require-

ments. Com-Tech 210 amplifiers are 3.5 inch (8.9 cm) high. North American models of Com-Tech 410 amplifiers are also 3.5 inch (8.9 cm) high. 50-Hz models of Com-Tech 410 amplifiers are 5.25 inch (13.3 cm) high. Com-Tech 810 amplifiers are 5.25 (13.3 cm) high. Com-Tech 1610 amplifiers are 7 inch (17.8 cm) high. (See Section 3.1 for more information).

**Approximate Weight:** Center of gravity is 6 inches (15.2 cm) behind the front mounting surface.

120 VAC, 60 Hz North American Units:

Com-Tech 210: 29 pounds, 7 ounces (13.4 kg) net;  
33 pounds, 14 ounces (15.4 kg) shipping weight.

Com-Tech 410: 31 pounds, 15 ounces (14.5 kg) net;  
36 pounds, 6 ounces (16.5 kg) shipping weight.

Com-Tech 810: 47 pounds, 4 ounces (21.5 kg) net;  
50 pounds, 8 ounces (22.9 kg) shipping weight.

Com-Tech 1610: 57 pounds, 14 ounces (26.3 kg)  
net; 66 pounds, 10 ounces (30.2 kg) shipping weight.

100/120 VAC, 50/60 Hz Units:

Com-Tech 210: 31 pounds, 6 ounces (14.2 kg) net;  
35 pounds, 8 ounces (16.1 kg) shipping weight.

Com-Tech 410: 38 pounds, 15 ounces (17.7 kg) net;  
43 pounds, 4 ounces (19.6 kg) shipping weight.

Com-Tech 810: 45 pounds, 1 ounces (20.5 kg) net;  
49 pounds, 10 ounces (22.5 kg) shipping weight.

Com-Tech 1610: 54 pounds, 11 ounces (24.8 kg)  
net; 64 pounds, 3 ounces (29.1 kg) shipping weight.

220/240 VAC, 50/60 Hz Units:

Com-Tech 210: 31 pounds, 12 ounces (14.4 kg) net;  
35 pounds, 14 ounces (16.3 kg) shipping weight.

Com-Tech 410: 38 pounds, 7 ounces (17.5 kg) net;  
42 pounds, 12 ounces (19.4 kg) shipping weight.

Com-Tech 810: 45 pounds, 4 ounces (20.5 kg) net;  
49 pounds, 13 ounces (22.6 kg) shipping weight.

Com-Tech 1610: 55 pounds, 2 ounces (25.0 kg) net;  
64 pounds, 10 ounces (29.3 kg) shipping weight.

### Crown specifications are guaranteed for three years.

In an effort to provide you with as much information as possible about the high power-producing capabilities of your amplifier, we have created the following power matrices.

#### Minimum Guaranteed Power Specifications

Crown's minimum power specifications represent the absolute smallest amount of output power you can expect from your amplifier when it is driven to full output under the given conditions. Some spaces in each matrix may be left blank because the same guarantee is not provided for those conditions—however, your amplifier will perform well under all conditions listed in each matrix.

When measuring power, 0.1% THD appears to be the industry standard for distortion. Two of the maximum average power specifications shown in each minimum power matrix are measured at 0.1% THD so you can easily compare Crown specifications to those of other manufacturers. But this high level of distortion actually allows for some clipping which is undesirable. Because of this, a maximum average power specification at 0.05% THD is included in each minimum power matrix which represents non-clipped conditions. Although most manufacturers do not give you power specifications at 0.05% THD, we encourage them to provide these specifications so you will have a more realistic representation of the way amplifiers should be used in the real world—without a clipped output signal.

Many manufacturers publish power specs with a tolerance of  $\pm 1$  dB or worse. This means their amplifier can deviate more than 20% in output! A 100 watt amplifier would meet their specification if it only produced 79.4 watts. Other manufacturers qualify their specs by

saying they are “typical,” “subject to manufacturing tolerances,” “single channel driven” or that they are specified with “fuses bypassed.” Each of these statements effectively removes any performance guarantee. In fact, some manufacturers use these tactics to generate large power numbers, and they don't even print a disclaimer. We take a different approach at Crown—our amplifiers are *guaranteed* to meet or exceed their specifications for three years. Further, because our published specs are set below our “in-house” measurements, you can expect *every Crown amplifier to exceed its published minimum power specs*. We believe you should get what you pay for.

#### Minimum Power Notes:

All minimum power specifications are based on 0.5% regulated AC mains with THD of less than 1.0% and an ambient room temperature of 70° F (21° C). Standard EIA power (RS-490) is not shown here because it is identical to FTC Continuous Average Power.

1. A 1 kHz sine wave is presented to the amplifier and the output monitored for nonlinear distortion. The level is increased until THD reaches 0.1%. At this point, average power per channel is reported.
2. A sine wave is presented to the amplifier over the range from 20 Hz to 20 kHz and the output monitored for nonlinear distortion. The level at each frequency is increased until THD reaches 0.1%. At this point, average power per channel is reported.
3. A 1 kHz sine wave is presented to the amplifier and the output monitored for nonlinear distortion. The level is increased until THD reaches 0.05%. At this point, average power per channel is reported.
4. Continuous power in the context of Federal Trade Commission testing is understood to be a minimum of five minutes of operation. Harmonic distortion is measured as the RMS sum total and given as a percentage of the fundamental output voltage. This applies for all wattages greater than 0.25 watts.

Com-Tech 210 – Minimum Guaranteed Power (Watts)							
AC Mains	Dual/Mono Mode	Load in Ohms (Constant Voltage)	Maximum Average			FTC Continuous Average	
			At 0.1% THD (See note 1)	At 0.1% THD (See note 2)	At 0.05% THD (See note 3)	At 0.1% THD (See note 4)	
			1 kHz	20Hz-20kHz	1 kHz	1 kHz	20Hz-20kHz
120 VAC, 60 Hz	Dual (both channels driven)	4	150	135	145	140	125
		8	110	105	105	105	100
		50 (70V)	110	105	110	110	105
	Bridge-Mono (balanced output)	8	300	270	295	270	250
		16	220	210	215	210	205
		100 (140V)	205	200	205	205	200
	Parallel-Mono	2	295		290	275	
		4	215		210	215	
		25 (70V)	210		205	205	
100/120 VAC, 50/60 Hz	Dual (both channels driven)	4	145	135	145	135	125
		8	110	105	110	110	105
		50 (70V)	105	95	105	100	95
	Bridge-Mono (balanced output)	8	290	265	285	275	250
		16	220	210	220	215	205
		100 (140V)	205	195	205	205	190
	Parallel-Mono	2	290		285	270	
		4	215		210	210	
		25 (70V)	210		205	205	
220/240 VAC, 50/60 Hz	Dual (both channels driven)	4	150	140	150	140	130
		8	115	110	115	110	105
		50 (70V)	105	100	105	105	95
	Bridge-Mono (balanced output)	8	300	275	295	280	260
		16	230	220	225	225	215
		100 (140V)	215	200	210	210	195
	Parallel-Mono	2	300		300	275	
		4	225		225	220	
		25 (70V)	215		215	210	

Fig. 6.1 Com-Tech 210 Minimum Power Matrix

Com-Tech 410 – Minimum Guaranteed Power (Watts)							
AC Mains	Dual/Mono Mode	Load in Ohms (Constant Voltage)	Maximum Average			FTC Continuous Average	
			At 0.1% THD (See note 1)	At 0.1% THD (See note 2)	At 0.05% THD (See note 3)	At 0.1% THD (See note 4)	
			1 kHz	20Hz-20kHz	1 kHz	1 kHz	20Hz-20kHz
120 VAC, 60 Hz	Dual (both channels driven)	4	240	215	235	225	200
		8	220	210	220	215	205
		25 (70V)	225	215	225	215	205
	Bridge-Mono (balanced output)	8	475	425	465	440	405
		16	450	425	440	430	405
		50 (140V)	455	435	450	435	415
	Parallel-Mono	2	440		430	415	
		4	440		440	425	
		12.5 (70V)	455		450	440	
100/120 VAC, 50/60 Hz	Dual (both channels driven)	4	240	215	235	225	200
		8	220	205	215	215	200
		25 (70V)	225	220	225	220	210
	Bridge-Mono (balanced output)	8	465	415	455	430	380
		16	435	410	435	430	405
		50 (140V)	455	435	450	440	415
	Parallel-Mono	2	450		445	420	
		4	445		445	435	
		12.5 (70V)	455		450	440	
220/240 VAC, 50/60 Hz	Dual (both channels driven)	4	240	215	240	225	200
		8	220	210	220	215	205
		25 (70V)	225	220	225	220	215
	Bridge-Mono (balanced output)	8	465	415	455	435	390
		16	445	420	440	435	410
		50 (140V)	460	440	455	445	430
	Parallel-Mono	2	430		425	405	
		4	435		430	430	
		12.5 (70V)	455		455	450	

Fig. 6.2 Com-Tech 410 Minimum Power Matrix

Com-Tech 810 – Minimum Guaranteed Power (Watts)							
AC Mains	Dual/Mono Mode	Load in Ohms (Constant Voltage)	Maximum Average			FTC Continuous Average	
			At 0.1% THD (See note 1)	At 0.1% THD (See note 2)	At 0.05% THD (See note 3)	At 0.1% THD (See note 4)	
			1 kHz	20Hz-20kHz	1 kHz	1 kHz	20Hz-20kHz
120 VAC, 60 Hz	Dual (both channels driven)	4	490	460	480	470	455
		8	305	295	300	300	290
		12.5 (70V)	460	455	455	450	445
	Bridge-Mono (balanced output)	8	975	935	965	950	905
		16	610	600	605	605	600
		25 (140V)	920	905	905	905	880
	Parallel-Mono	2	965		950	950	
		4	610		600	605	
		6.25 (70V)	915		905	910	
100/120 VAC, 50/60 Hz	Dual (both channels driven)	4	460	440	460	445	425
		8	300	290	295	295	290
		12.5 (70V)	425	415	420	410	400
	Bridge-Mono (balanced output)	8	925	885	915	890	840
		16	600	580	595	595	575
		25 (140V)	855	825	850	830	800
	Parallel-Mono	2	925		920	895	
		4	600		595	595	
		6.25 (70V)	855		845	830	
220/240 VAC, 50/60 Hz	Dual (both channels driven)	4	485	470	485	465	450
		8	310	305	310	310	300
		12.5 (70V)	440	430	435	425	420
	Bridge-Mono (balanced output)	8	965	920	955	930	875
		16	620	605	615	615	600
		25 (140V)	885	855	875	865	840
	Parallel-Mono	2	940		930	920	
		4	615		610	600	
		6.25 (70V)	875		870	855	

Fig. 6.3 Com-Tech 810 Minimum Power Matrix

Com-Tech 1610 – Minimum Guaranteed Power (Watts)							
AC Mains	Dual/Mono Mode	Load in Ohms (Constant Voltage)	Maximum Average			FTC Continuous Average	
			At 0.1% THD (See note 1)	At 0.1% THD (See note 2)	At 0.05% THD (See note 3)	At 0.1% THD (See note 4)	
			1 kHz	20Hz-20kHz	1 kHz	1 kHz	20Hz-20kHz
120 VAC, 60 Hz	Dual (both channels driven)	4	870	810	860	850	
		8	540	520	535	540	510
		6.25 (70V)	960	910	955	960	
	Bridge-Mono (balanced output)	8	1745	1595	1725	1700	
		16	1080	1040	1070	1075	1040
		12.5 (140V)	1805	1725	1795	1770	
	Parallel-Mono	2	1745		1720	1690	
		4	1080		1070	1075	
		3.13 (70V)	1780		1760	1745	
100/120 VAC, 50/60 Hz	Dual (both channels driven)	4	815	775	805		
		8	535	515	530	530	510
		6.25 (70V)	860	830	850	815	
	Bridge-Mono (balanced output)	8	1625	1545	1615		
		16	1070	1035	1060	1055	1020
		12.5 (140V)	1700	1640	1695	1625	
	Parallel-Mono	2	1660		1640		
		4	1080		1070	1060	
		3.13 (70V)	1700		1690	1620	
220/240 VAC, 50/60 Hz	Dual (both channels driven)	4	840	785	840		
		8	545	525	540	540	505
		6.25 (70V)	875	755	870	850	
	Bridge-Mono (balanced output)	8	1675	1550	1665		
		16	1090	910	1075	1070	900
		12.5 (140V)	1755	1315	1745	1710	
	Parallel-Mono	2	1650		1635		
		4	1075		1065	1065	
		3.13 (70V)	1745		1735	1715	

Fig. 6.4 Com-Tech 1610 Minimum Power Matrix

## Maximum Power Specifications

Crown's maximum power specifications represent the largest amount of output power you can expect from your amplifier when it is driven to full output under the given conditions. These specifications can be used to prevent loudspeaker and hearing damage.

The maximum power matrices include specifications for single cycle and 40-millisecond burst sine waves. Burst signals act like large transient peaks that are present in common source signals. Loudspeakers can respond to a single cycle burst, so the single cycle burst specifications should be used to help you protect your loudspeakers. In contrast, a 40 millisecond burst represents the typical response time of the human ear. Your ear will not respond to the entire dynamic change of a burst that lasts less than 40 milliseconds.

The burst power specifications are provided at 0.05% THD which is a practical low distortion condition. Operating the amplifier at levels higher than 0.05% THD can result in output power levels that are higher than those listed in the maximum power matrices.

Com-Tech 210 – Maximum Power (Watts)									
AC Mains	Dual/Mono Mode	Load in Ohms (Constant Voltage)	Single Cycle Tone Burst At less than 0.05% THD (See note 1)				40 Millisecond Tone Burst At 0.05% THD (See note 2)		
			20 Hz	50 Hz	1 kHz	7 kHz	50 Hz	1 kHz	7 kHz
			120 VAC, 60 Hz	Dual (both channels driven)	4	170	205	275	275
8	130	145			165	165	130	115	120
50 (70V)	130	135			140	135	130	125	130
Bridge-Mono (balanced output)	8	355		400	535	530	345	310	325
	16	255		280	325	320	250	225	240
	100 (140V)	255		270	275	265	255	250	255
Parallel-Mono	2	345		405	520	520	345	300	315
	4	255		280	315	315	245	220	230
	25 (70V)	255		270	280	265	255	245	255
100/120 VAC, 50/60 Hz	Dual (both channels driven)	4	165	220	310	305	190	165	175
		8	125	155	185	180	135	125	130
		50 (70V)	140	150	150	145	140	135	140
	Bridge-Mono (balanced output)	8	325	435	600	605	380	325	345
		16	250	300	360	360	265	245	255
		100 (140V)	275	295	305	290	275	265	275
	Parallel-Mono	2	325	425	580	585	360	310	335
		4	245	305	355	355	265	235	250
		25 (70V)	275	295	305	290	275	265	275
220/240 VAC, 50/60 Hz	Dual (both channels driven)	4	165	225	315	310	190	165	175
		8	130	155	185	185	140	125	130
		50 (70V)	140	150	155	150	140	135	140
	Bridge-Mono (balanced output)	8	330	440	625	625	375	325	345
		16	250	310	370	370	270	245	260
		100 (140V)	305	310	315	300	310	310	300
	Parallel-Mono	2	315	425	595	590	370	315	335
		4	250	305	365	360	270	240	255
		25 (70V)	280	295	305	295	280	270	280

### Maximum Power Notes:

All maximum power specifications are based on 0.5% regulated AC mains with THD of less than 1.0% and an ambient room temperature of 70° F (21° C). Although it is an unusual condition, your amplifier can function well with AC mains voltages up to 10% over the specified line voltage. With overvoltage conditions, your amplifier may be capable of delivering instantaneous power levels up to 20% greater than the specifications in the matrix.

1. A single cycle sine wave is presented to the amplifier and monitored for nonlinear distortion. The average power during the burst is reported. Loudspeakers must be able to withstand this level if they are to be safely used with this amplifier.
2. A 40 millisecond sine wave burst (10 percent duty cycle) is presented to the amplifier and monitored for nonlinear distortion. Average power during the burst is reported. This power level is a measurement of the amplifier's maximum transient power that can be perceived by the human ear.

Fig. 6.5 Com-Tech 210 Maximum Power Matrix

Com-Tech 410 – Maximum Power (Watts)									
AC Mains	Dual/Mono Mode	Load in Ohms (Constant Voltage)	Single Cycle Tone Burst At less than 0.05% THD (See note 1)				40 Millisecond Tone Burst At 0.05% THD (See note 2)		
			20 Hz	50 Hz	1 kHz	7 kHz	50 Hz	1 kHz	7 kHz
			120 VAC, 60 Hz	Dual (both channels driven)	4	320	415	460	450
8	265	300			360	355	260	235	250
25 (70V)	305	330			340	330	305	290	305
Bridge-Mono (balanced output)	8	620		820	875	855	695	620	645
	16	520		600	720	705	510	475	490
	50 (140V)	590		655	675	655	600	575	595
Parallel-Mono	2	615		805	825	810	685	615	645
	4	505		595	715	700	515	470	490
	12.5 (70V)	595		650	680	655	600	575	695
100/120 VAC, 50/60 Hz	Dual (both channels driven)	4	315	415	555	550	360	315	330
		8	240	285	330	325	255	230	240
		25 (70V)	280	310	325	315	285	270	280
	Bridge-Mono (balanced output)	8	620	820	1110	1095	725	620	655
		16	475	570	665	660	500	455	480
		50 (140V)	555	615	645	630	565	540	565
	Parallel-Mono	2	610	790	1080	1070	710	605	635
		4	470	560	655	640	495	450	470
		12.5 (70V)	550	615	645	620	565	535	560
220/240 VAC, 50/60 Hz	Dual (both channels driven)	4	315	405	435	435	360	310	330
		8	240	285	335	325	250	230	240
		25 (70V)	280	315	325	315	290	275	285
	Bridge-Mono (balanced output)	8	625	820	860	865	725	625	650
		16	475	575	665	655	500	455	480
		50 (140V)	665	675	680	650	675	675	650
	Parallel-Mono	2	605	745	745	745	700	600	625
		4	465	565	645	640	490	445	465
		12.5 (70V)	550	610	645	620	565	535	555

Fig. 6.6 Com-Tech 410 Maximum Power Matrix



Com-Tech 810 – Maximum Power (Watts)									
AC Mains	Dual/Mono Mode	Load in Ohms (Constant Voltage)	Single Cycle Tone Burst At less than 0.05% THD (See note 1)				40 Millisecond Tone Burst At 0.05% THD (See note 2)		
			20 Hz	50 Hz	1 kHz	7 kHz	50 Hz	1 kHz	7 kHz
			120 VAC, 60 Hz	Dual (both channels driven)	4	515	575	695	690
8	320	340			385	375	320	300	310
12.5 (70V)	480	530			590	575	480	455	475
Bridge-Mono (balanced output)	8	1010		1120	1405	1385	1060	945	995
	16	640		680	770	755	650	595	620
	25 (140V)	980		1045	1185	1145	960	910	955
Parallel-Mono	2	1060		1160	1390	1380	1100	950	985
	4	645		685	765	755	650	590	615
	6.25 (70V)	975		1045	1170	1135	985	910	945
100/120 VAC, 50/60 Hz	Dual (both channels driven)	4	460	605	750	730	555	470	490
		8	230	295	375	370	275	235	245
		12.5 (70V)	475	545	610	595	510	470	490
	Bridge-Mono (balanced output)	8	915	1195	1500	1480	1110	935	980
		16	600	705	810	790	665	600	630
		25 (140V)	920	1085	1230	1190	990	910	955
	Parallel-Mono	2	900	1195	1485	1450	1075	920	960
		4	600	700	805	780	660	600	625
		6.25 (70V)	915	1070	1210	1185	975	905	945
220/240 VAC, 50/60 Hz	Dual (both channels driven)	4	475	610	755	740	570	485	500
		8	305	360	405	395	340	305	320
		12.5 (70V)	475	545	615	590	505	475	490
	Bridge-Mono (balanced output)	8	930	1190	1530	1470	1095	945	985
		16	605	705	815	785	675	605	635
		25 (140V)	920	1085	1225	1180	980	910	945
	Parallel-Mono	2	910	1185	1475	1415	1085	920	955
		4	600	710	790	770	665	595	620
		6.25 (70V)	915	1080	1225	1175	985	910	940

Fig. 6.7 Com-Tech 810 Maximum Power Matrix

Com-Tech 1610 – Maximum Power (Watts)									
AC Mains	Dual/Mono Mode	Load in Ohms (Constant Voltage)	Single Cycle Tone Burst At less than 0.05% THD (See note 1)				40 Millisecond Tone Burst At 0.05% THD (See note 2)		
			20 Hz	50 Hz	1 kHz	7 kHz	50 Hz	1 kHz	7 kHz
			120 VAC, 60 Hz	Dual (both channels driven)	4	780	1000	1245	1215
8	525	600			670	655	555	525	545
6.25 (70V)	950	1035			1205	1170	925	875	905
Bridge-Mono (balanced output)	8	1600		1995	2480	2420	1875	1670	1745
	16	1050		1185	1330	1285	1145	1050	1090
	12.5 (140V)	1770		1980	2315	2225	1785	1675	1735
Parallel-Mono	2	1590		1985	2465	2390	1830	1665	1715
	4	1140		1170	1330	1300	1130	1045	1080
	3.13 (70V)	1895		2015	2375	2280	1880	1715	1780
100/120 VAC, 50/60 Hz	Dual (both channels driven)	4	820	1060	1370	1335	1005	835	870
		8	555	655	750	720	610	550	570
		6.25 (70V)	955	1100	1295	1255	1025	895	930
	Bridge-Mono (balanced output)	8	1635	2095	2700	2680	1930	1650	1735
		16	1090	1285	1475	1440	1200	1080	1130
		12.5 (140V)	1895	2165	2550	2490	1985	1760	1825
	Parallel-Mono	2	1640	2105	2715	2630	1955	1655	1725
		4	1090	1300	1470	1425	1195	1080	1120
		3.13 (70V)	1845	2110	2530	2430	1965	1745	1810
220/240 VAC, 50/60 Hz	Dual (both channels driven)	4	800	1060	1295	1245	955	820	850
		8	535	630	700	685	590	530	550
		6.25 (70V)	885	1025	1210	1165	960	845	875
	Bridge-Mono (balanced output)	8	1600	2060	2580	2520	1915	1630	1695
		16	1055	1225	1410	1365	1155	1050	1095
		12.5 (140V)	1800	2115	2475	2395	1935	1720	1800
	Parallel-Mono	2	1615	2100	2585	2525	1920	1635	1700
		4	1065	1230	1415	1380	1175	1055	1095
		3.13 (70V)	1855	2080	2450	2315	1940	1720	1785

Fig. 6.8 Com-Tech 1610 Maximum Power Matrix

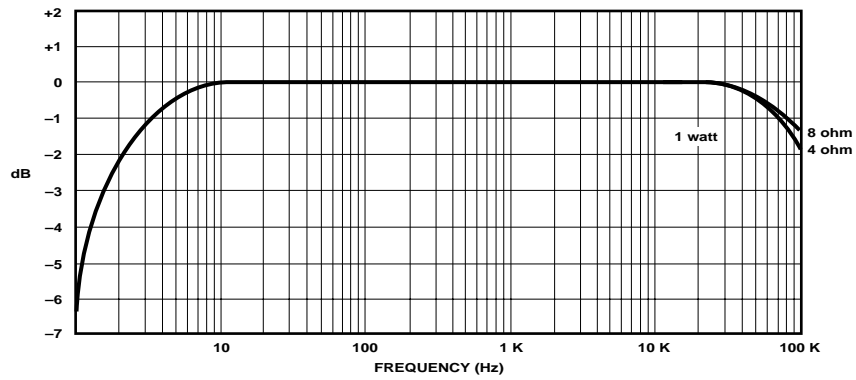

Fig. 6.9 Typical Frequency Response

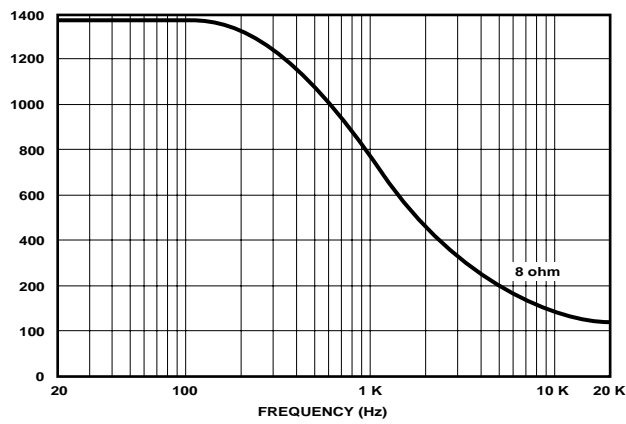

Fig. 6.10 Typical Damping Factor

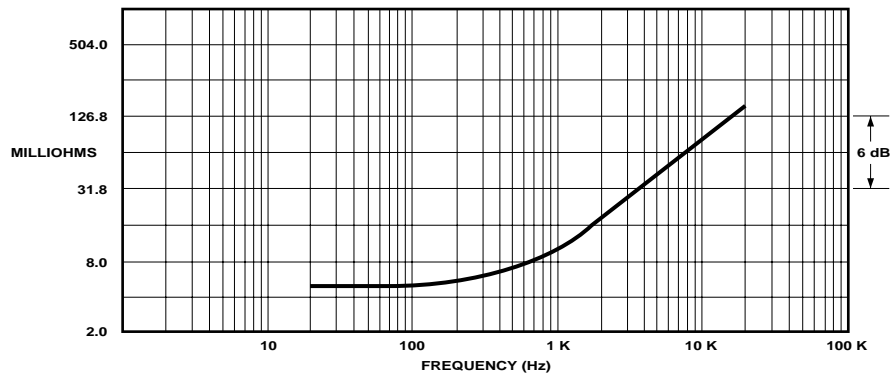

Fig. 6.11 Typical Output Impedance

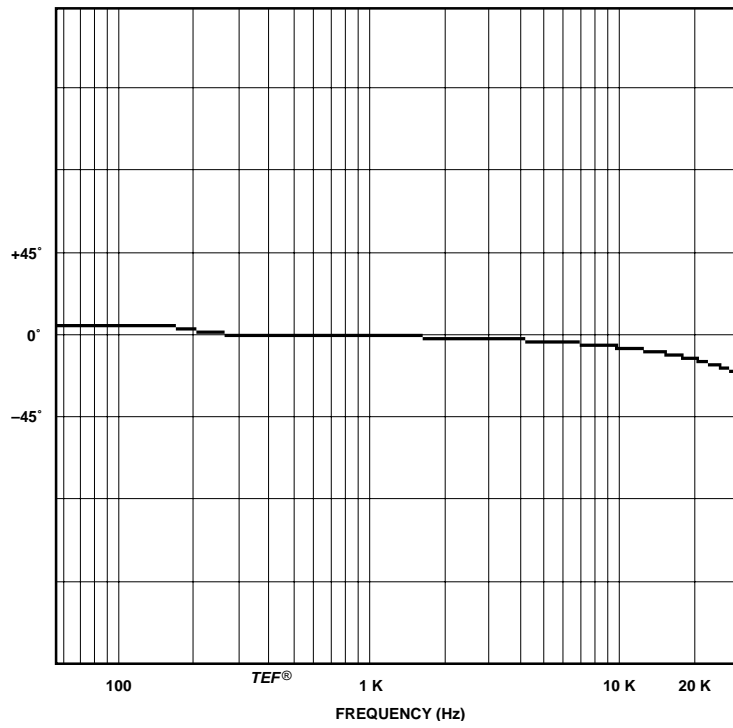

Fig. 6.12 Typical Phase Response

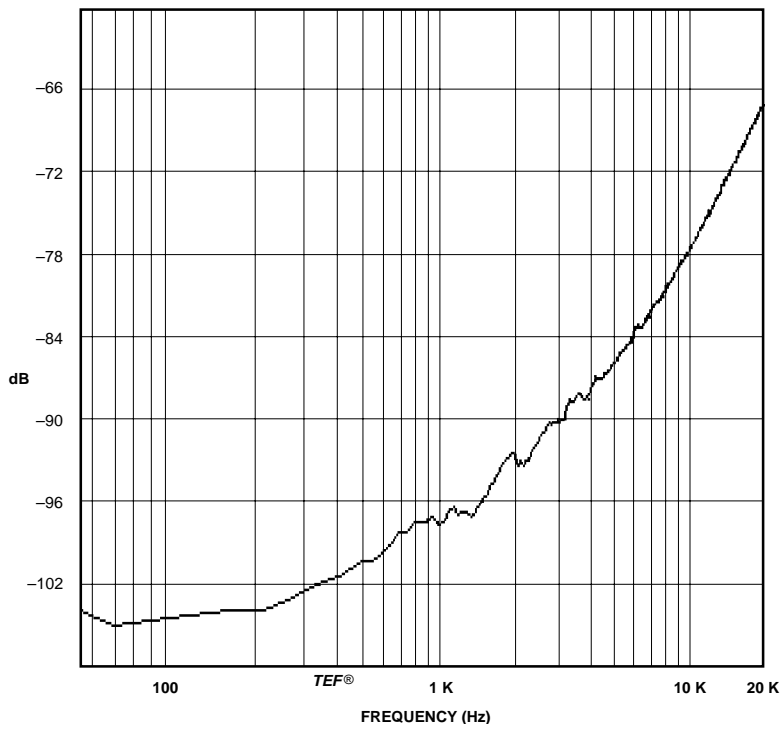

Fig. 6.13 Typical Crosstalk

## 7 AC Power Draw and Thermal Dissipation

**“Soft-Start”** inrush current limiting, protects the house circuit breaker when several amps are turned on simultaneously.

This section provides detailed information about the amount of power and current drawn from the AC mains by Com-Tech amplifiers and the amount of heat produced under various conditions. The calculations presented here are intended to provide a realistic and reliable depiction of the amplifiers. The following assumptions or approximations were made:

- The amplifier’s available channels are loaded, and full power is being delivered.
- Amplifier efficiency at standard 1 kHz power is estimated to be 65%.
- In 8/4 ohm mode, typical quiescent power draw is 20 watts for the Com-Tech 210, 30 watts for the Com-Tech 410, 55 watts for the Com-Tech 810 and 70 watts for the Com-Tech 1610.
- In 70 volt mode, typical quiescent power draw is 30 watts for the Com-Tech 210, 35 watts for the Com-Tech 410, and 90 watts for the Com-Tech 810 and 1610.
- When running at full speed, typical power draw for the internal fan is 11 watts for the Com-Tech 210, 410 and 810, and 17 watts for the Com-Tech 1610 (the fan is an option for the Com-Tech 210).
- Quiescent thermal dissipation is related .
- The estimated duty cycles take into account the typical crest factor for each type of source material.
- Duty cycle of pink noise is 50%.
- Duty cycle of highly compressed rock ‘n’ roll midrange is 40%.

- Duty cycle of rock ‘n’ roll is 30%.
- Duty cycle of background music is 20%.
- Duty cycle of continuous speech is 10%.
- Duty cycle of infrequent paging is 1%.

Here are the equations used to calculate the data presented in Figures 7.1 through 7.4:

$$\text{AC Mains Power Draw (watts)} = \frac{\text{Total output power with all channels driven (watts)} \times \text{Duty Cycle}}{\text{Amplifier Efficiency (.65)}} + \text{Quiescent Power Draw (watts)}$$

The value used for quiescent power draw includes both the amplifier’s quiescent power draw for the selected output mode and the power drawn by the fan if one is installed (these values are listed in the previous column). The following equation converts power draw in watts to current draw in amperes:

$$\text{Current Draw (amperes)} = \frac{\text{AC Mains Power Draw (watts)}}{\text{AC Mains Voltage} \times \text{Power Factor (.83)}}$$

The power factor of 0.83 is needed to compensate for the difference in phase between the AC mains voltage and current. The following equation is used to calculate thermal dissipation:

$$\text{Thermal Dissipation (btu/hr)} = \left( \frac{\text{Total output power with all channels driven (watts)} \times \text{Duty Cycle} \times .35}{\text{Amplifier Efficiency (.65)}} + \text{Quiescent Power Draw (watts)} \right) \times 3.415$$

The constant 0.35 is inefficiency (1.00–0.65) and the factor 3.415 converts watts to btu/hr. Thermal dissipation in btu is divided by the constant 3.968 to get kcal. If you plan to measure output power under real-world conditions, the following equation may also be helpful:

$$\text{Thermal Dissipation (btu/hr)} = \left( \frac{\text{Total measured output power from all channels (watts)} \times .35}{\text{Amplifier Efficiency (.65)}} + \text{Quiescent Power Draw (watts)} \right) \times 3.415$$

### Com-Tech 210

Duty Cycle	L O A D														
	AC Mains Power Draw (Watts)	8 Ohm Dual / 16 Ohm Bridge-Mono / 4 Ohm Parallel-Mono				4 Ohm Dual / 8 Ohm Bridge-Mono / 2 Ohm Parallel-Mono				70 V					
		Current Draw (Amps)		Thermal Dissipation		AC Mains Power Draw (Watts)	Current Draw (Amps)		Thermal Dissipation		AC Mains Power Draw (Watts)	Current Draw (Amps)		Thermal Dissipation	
100-120 V	220-240 V	btu/hr	kcal/hr	100-120 V	220-240 V		btu/hr	kcal/hr	100-120 V	220-240 V		btu/hr	kcal/hr		
50%	200	2.4	1.1	305	80	265	3.1	1.4	380	95	210	2.5	1.1	340	85
40%	165	2.0	0.9	265	70	215	2.6	1.2	325	85	175	2.1	1.0	300	75
30%	135	1.6	0.7	225	60	170	2.0	0.9	270	70	145	1.7	0.8	260	65
20%	100	1.2	0.5	185	50	125	1.5	0.7	215	55	110	1.3	0.6	220	55
10%	65	0.8	0.3	145	40	80	0.9	0.4	160	40	75	0.9	0.4	180	45

Fig. 7.1 Com-Tech 210 Power Draw, Current Draw and Thermal Dissipation at Various Duty Cycles

**Com-Tech 410**

Duty Cycle	L O A D														
	8 Ohm Dual / 16 Ohm Bridge-Mono / 4 Ohm Parallel-Mono					4 Ohm Dual / 8 Ohm Bridge-Mono / 2 Ohm Parallel-Mono					70 V				
	AC Mains Power Draw (Watts)	Current Draw (Amps)		Thermal Dissipation		AC Mains Power Draw (Watts)	Current Draw (Amps)		Thermal Dissipation		AC Mains Power Draw (Watts)	Current Draw (Amps)		Thermal Dissipation	
		100-120 V	220-240 V	btu/hr	kcal/hr		100-120 V	220-240 V	btu/hr	kcal/hr		100-120 V	220-240 V	btu/hr	kcal/hr
50%	390	4.7	2.1	550	140	410	4.9	2.2	580	150	395	4.8	2.2	575	145
40%	320	3.8	1.7	470	120	335	4.0	1.8	490	125	325	3.9	1.8	490	125
30%	250	3.0	1.4	385	100	265	3.2	1.4	400	100	255	3.1	1.4	405	105
20%	180	2.2	1.0	305	80	190	2.3	1.0	315	80	185	2.2	1.0	320	80
10%	110	1.3	0.6	220	55	115	1.4	0.6	225	60	115	1.4	0.6	240	60

Fig. 7.2 Com-Tech 410 Power Draw, Current Draw and Thermal Dissipation at Various Duty Cycles

**Com-Tech 810**

Duty Cycle	L O A D														
	8 Ohm Dual / 16 Ohm Bridge-Mono / 4 Ohm Parallel-Mono					4 Ohm Dual / 8 Ohm Bridge-Mono / 2 Ohm Parallel-Mono					70 V				
	AC Mains Power Draw (Watts)	Current Draw (Amps)		Thermal Dissipation		AC Mains Power Draw (Watts)	Current Draw (Amps)		Thermal Dissipation		AC Mains Power Draw (Watts)	Current Draw (Amps)		Thermal Dissipation	
		100-120 V	220-240 V	btu/hr	kcal/hr		100-120 V	220-240 V	btu/hr	kcal/hr		100-120 V	220-240 V	btu/hr	kcal/hr
50%	535	6.4	2.9	785	200	820	9.9	4.5	1125	285	810	9.7	4.4	1190	300
40%	440	5.3	2.4	670	170	670	8.0	3.7	945	240	670	8.0	3.6	1020	260
30%	350	4.2	1.9	560	140	520	6.2	2.8	765	195	525	6.3	2.9	850	215
20%	255	3.0	1.4	450	115	370	4.4	2.0	585	150	385	4.6	2.1	680	170
10%	160	1.9	0.9	335	85	220	2.6	1.2	405	100	245	2.9	1.3	510	130

Fig. 7.3 Com-Tech 810 Power Draw, Current Draw and Thermal Dissipation at Various Duty Cycles

**Com-Tech 1610**

Duty Cycle	L O A D														
	8 Ohm Dual / 16 Ohm Bridge-Mono / 4 Ohm Parallel-Mono					4 Ohm Dual / 8 Ohm Bridge-Mono / 2 Ohm Parallel-Mono					70 V				
	AC Mains Power Draw (Watts)	Current Draw (Amps)		Thermal Dissipation		AC Mains Power Draw (Watts)	Current Draw (Amps)		Thermal Dissipation		AC Mains Power Draw (Watts)	Current Draw (Amps)		Thermal Dissipation	
		100-120 V	220-240 V	btu/hr	kcal/hr		100-120 V	220-240 V	btu/hr	kcal/hr		100-120 V	220-240 V	btu/hr	kcal/hr
50%	920	11.1	5.0	1300	330	1435	17.3	7.8	1915	485	1590	19.1	8.7	2140	540
40%	755	9.1	4.1	1100	280	1165	14.0	6.4	1590	400	1295	15.6	7.1	1790	450
30%	590	7.1	3.2	905	230	895	10.8	4.9	1270	320	1000	12.0	5.5	1435	365
20%	425	5.1	2.3	705	180	630	7.6	3.4	950	240	700	8.4	3.8	1085	275
10%	260	3.1	1.4	510	130	360	4.3	2.0	630	160	405	4.9	2.2	730	185

Fig. 7.4 Com-Tech 1610 Power Draw, Current Draw and Thermal Dissipation at Various Duty Cycles

## 8 Accessories

### 8.1 PIP and PIP2 Modules

One advantage of Crown PIP2 compatible amplifiers is the ability to customize them using PIP (Programmable Input Processor) and PIP2 modules. The PIPs shown here may be used in any Crown PIP2-compatible amplifier. PIPs carrying the PIP2 logo have been configured with an extended, PIP2-enhanced feature set.

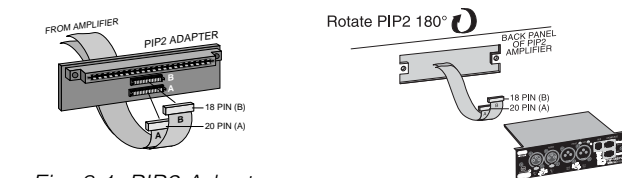

Fig. 8.1 PIP2 Adaptor Connection

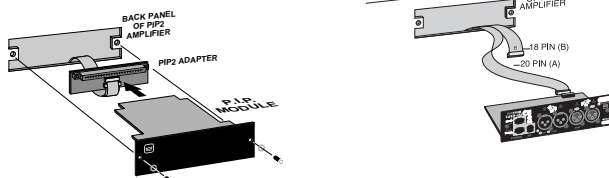

Fig. 8.2 Installing a PIP Module

The modules install easily: For PIP units featuring an edge-connector, first install the PIP2 adapter, then carefully slide the PIP card edge into the adapter's edge connector. Finally, insert the combined units into the amplifier and screw securely into place (see Figures 8.1 and 8.2).

For PIP2s featuring ribbon cable connectors, simply locate the two connectors on the underside of the PIP circuit board, then connect the two input ribbon cables coming from the amplifier. Both ribbon cables should run smoothly from the amplifier to the PIP card. Insert the PIP and attached cables into the PIP opening in the back of the amplifier, then screw securely into place (see Figure 8.3).



**WARNING: Disconnect power to the amplifier when installing or removing a PIP module.**

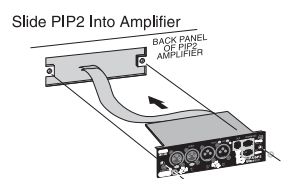
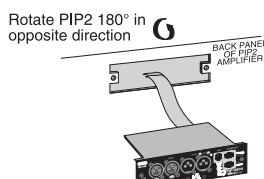
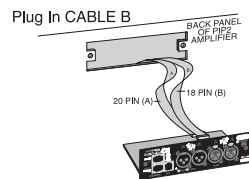
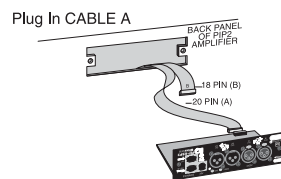
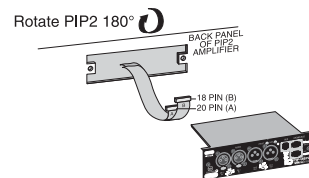

For more information on these or other PIPs under development, contact your local dealer or Crown's Technical Support Group.



**IQ-P.I.P.-DSP** is an IQ System Programmable Input Processor with DSP (Digital Signal Processing) for PIP-compatible amplifiers. As a component of the IQ System, it connects the amplifier to the Crown Bus so the amplifier can be controlled and monitored. Its DSP capabilities enable it to be programmed with a variety of functions, such as filters and crossovers, signal delay, input compressor and output limiter, and a variety of other useful features similar to those included with the IQ-P.I.P.-SMT. Requires an IQ2 interface and a computer for initial setup.

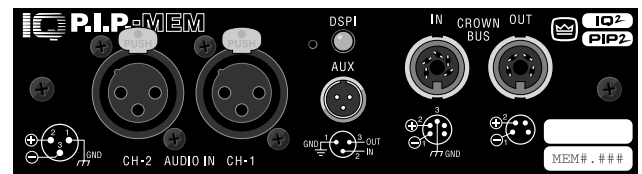

**IQ-P.I.P.-MEM** Integrates Crown PIP-compatible amplifiers into Crown's IQ System. Each channel of each amplifier can be monitored and individually controlled from an inexpensive PC. A total of 15 functions can be either monitored or controlled. Memory backup is also incorporated in case of power failure. Requires an IQ2 interface and a computer for initial setup.

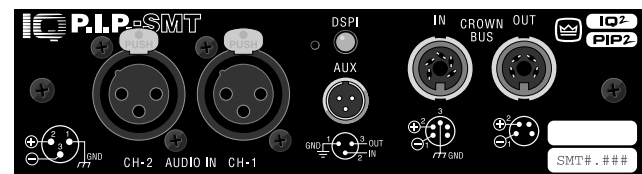

**IQ-P.I.P.-SMT** "Smart Amp" offers impressive new features unavailable elsewhere. The processing speed is substantially enhanced over other designs. A programmable power-supply gate conserves energy by shutting off the amplifier's high-power supplies until an audio signal is present. The user may define error-reporting conditions of the amplifier. There is much greater flexibility and thermal operational protection available, as well as a built-in smooth output limiter to discretely control maximum amplifier output. Requires an IQ2 interface and a computer for initial setup.

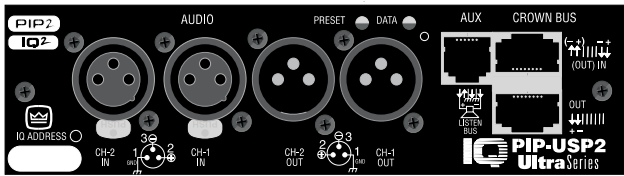

**IQ-PIP-USB2** is an IQ2-series component. This means it supports Crown's UCODE protocol and requires an IQ System with an IQ2-compatible IQ interface. UCODE (universal code) enables users and third parties to develop custom software objects to control and monitor IQ2-compatible components like the IQ-PIP-USB2.

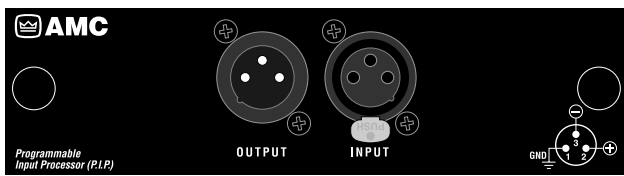

**P.I.P.-AMCb** combines many of the features found in the P.I.P.-XOV and P.I.P.-CLP to provide both a variable 4th-order Linkwitz-Riley crossover and an IOC-driven or variable-threshold signal-driven compressor. In addition, variable equalization networks provide for "constant-directivity" horn equalization and filter-assisted B6 vented bass box equalization. Bi-amping and tri-amping capabilities are provided via XLR connectors.

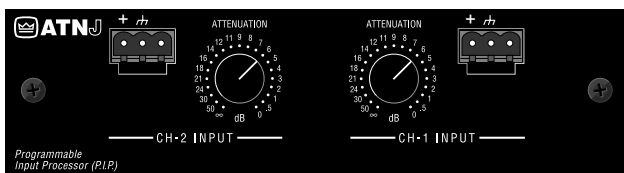

**P.I.P.-ATNJ** includes the features of the P.I.P.-FXT (balanced Jensen® 1:1 isolation transformers) and adds to each channel a 12-dB/octave RFI filter, a variable 18-dB/octave high-pass filter (to reduce bass/subsonic frequencies), and a 6-dB/octave 3-kHz shelving network for "constant-directivity" horn equalization. Special quick-connect barrier blocks are provided for inputs to each channel. Also adds a Jensen® 32-step precision attenuator to each channel.

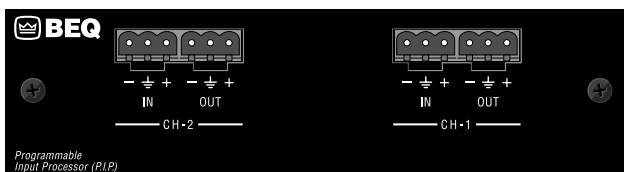

**P.I.P.-BEQC** adds many features of the Bose® Controllers to the input of your amplifier. Each channel includes a custom equalization network for Bose loudspeakers. Also included is a bass-cut (high-pass) filter for each channel. The equalization and bass-cut filters can be bypassed, if desired. Balanced inputs and "daisy-chain" outputs use

removable barrier block connectors for quick, solderless connections.

**P.I.P.-BEQX** Same as P.I.P.-BEQC but with XLR connectors.

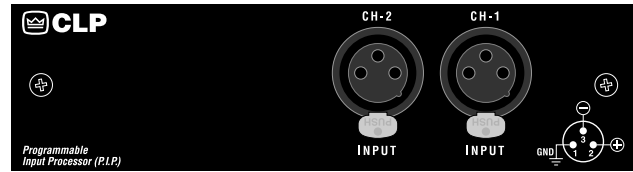

**P.I.P.-CLP** is designed to detect and prevent overload. The same error detecting circuit that is used to signal the IOC indicator is used to activate this error-driven compressor. It is not a typical signal-driven compressor, but a circuit to prevent any overload. It can yield up to 13 dB or additional signal safety margin without noticeable program change.

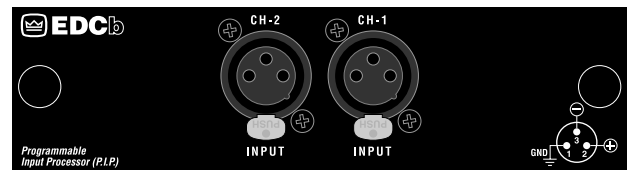

**P.I.P.-EDCb** State-of-the-art programmable error-driven and signal-driven compressor plus a variable high-pass filter for each channel. Fast or slow attach and release times can be set independently for each channel.

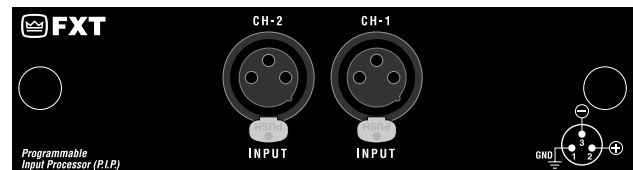

**P.I.P.-FXT** uses balanced 1:1 transformers to isolate the source from the inputs. It comes with balanced female 3-pin XLR connectors.

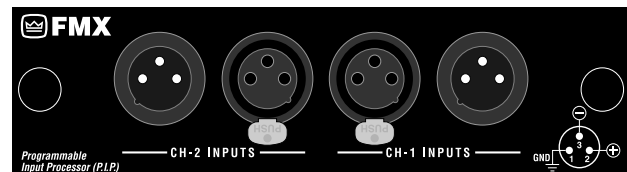

**P.I.P.-FMX** facilitates "daisy-chaining" several amplifier balanced inputs together. Female to male 3-pin XLR connectors are used to passively bridge the amplifier inputs.

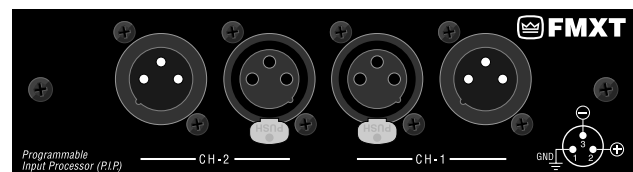

**P.I.P.-FMXT** Same as P.I.P.-FMX but includes input transformers.



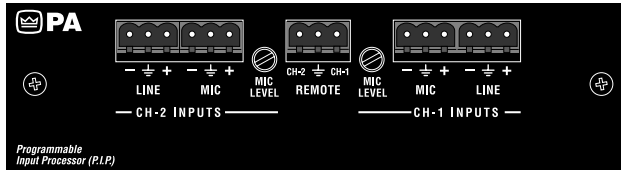

**P.I.P.-PA** permits the unique capability of adding one mic/line input directly to each channel of an amplifier. With phantom power for microphones, this mic/line input may be remotely switched from mic to line priorities.

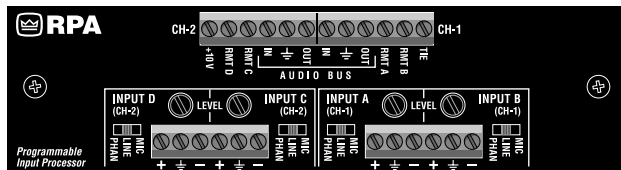

**P.I.P.-RPA** A phantom-power mixer that has four balanced mic or line inputs with voiceover capability and adjustable “duck” level, 84 dB of attenuation. A 10-volt DC source for remote control capability is provided. The P.I.P.-EXT (Part M44731-4), available from service, allows the P.I.P.-RPA and other PIP cards to be “extended” outside the amplifier for easy set up.

**P.I.P.-RPAT** has the same features as the P.I.P.-RPA but includes four input transformers.

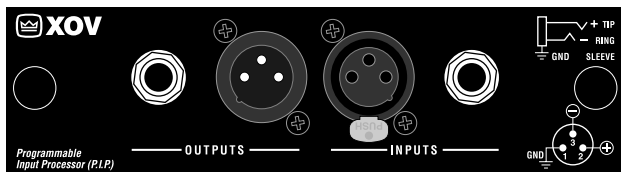

**P.I.P.-XOV** is a versatile, economical mono 12- or 18-dB/octave crossover/filter which offers bi-amping and tri-amping capability.

## 8.2 R.S.V.P. Module



**R.S.V.P.** The R.S.V.P. (Remote Switching Voltage Provider) can be used in applications requiring remote power turn on/off of banks of amplifiers. Each R.S.V.P. can control up to 20 CT-10 Series amplifiers and/or daisy chain to other R.S.V.P. modules, allowing larger systems to be controlled. The R.S.V.P. can also be controlled by the IQ-PIP AUX output.

## 8.3 Com-Tech 210 Cooling Fan

A cooling fan (part GCT200FAN) is available for North American Com-Tech 210s (all other units include a fan). We recommend the kit if you will be operating a Com-Tech 210 at high levels, in high temperatures for long periods, or with high duty cycle input signal, (see Section 3.2.1). Contact an authorized Crown servicer for installation of the optional fan kit.

## 8.4 Constant Voltage Computer

Crown's constant voltage computer is a easy-to-use slide rule for audio applications. The first scale finds the impedance of a step-down transformer based on delivered power and the transformer's rated voltage. This scale also identifies the proper transformer tap to use when a particular constant voltage rating is not provided with the transformer (such as 25, 35, 50, 70, 100 or 140 volts). Other scales include line loss, parallel resistance, dB-SPL vs. distance and dB-SPL vs. power. To obtain a constant voltage computer, call our Technical Support Group and ask for literature.

## 9 Service

This unit has very sophisticated circuitry which should only be serviced by a fully trained technician. This is one reason why each unit bears the following label:



**CAUTION: To prevent electric shock, do not remove covers. No user serviceable parts inside. Refer servicing to a qualified technician.**

### 9.1 Worldwide Service

Service may be obtained from an authorized service center. (Contact your local Crown/Amcron representative or our office for a list of authorized service centers.) To obtain service, simply present the bill of sale as proof of purchase along with the defective unit to an authorized service center. They will handle the necessary paperwork and repair.

Remember to transport your unit in the original factory pack.

### 9.2 North American Service

Service may be obtained in one of two ways: from an authorized service center or from the factory. You may choose either. It is important that you have your copy of the bill of sale as your proof of purchase.

#### 9.2.1 Service at a North American Service Center

This method usually saves the most time and effort. Simply present your bill of sale along with the defective unit to an authorized service center to obtain service. They will handle the necessary paperwork and repair. Remember to transport the unit in the original factory pack. A list of authorized service centers in your area can be obtained from our Technical Support Group.

#### 9.2.2 Factory Service

To obtain factory service, fill out the **service information page** found in the back of this manual and send it along with your proof of purchase and the defective unit to the Crown factory.

For warranty service, we will pay for ground shipping both ways in the United States. Contact Crown Factory Service or Technical Support to obtain prepaid shipping labels prior to sending the unit. Or, if you prefer, you may prepay the cost of shipping, and Crown will reimburse you. Send copies of the shipping receipts to Crown to receive reimbursement.

Your repaired unit will be returned via UPS ground. Please contact us if other arrangements are required.

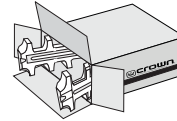

**Always use the original factory pack to transport the unit.**

### Factory Service Shipping Instructions:

1. When sending a Crown product to the factory for service, be sure to fill out the service information form that follows and enclose it inside your unit's shipping pack. Do not send the service information form separately.
2. To ensure the safe transportation of your unit to the factory, ship it in an original factory packing container. If you don't have one, call or write Crown's Parts Department. With the exception of polyurethane or wooden crates, any other packing material will not be sufficient to withstand the stress of shipping. **Do not use loose, small size packing materials.**
3. Do not ship the unit in any kind of cabinet (wood or metal). Ignoring this warning may result in extensive damage to the unit and the cabinet. Accessories are not needed—do not send the product documentation, cables and other hardware.

If you have any questions, please call or write the Crown Technical Support Group.

#### Crown Customer Service

Technical Support / Factory Service  
Plant 2 SW, 1718 W. Mishawaka Rd., Elkhart,  
Indiana 46517 U.S.A.

*Telephone:* 219-294-8200  
800-342-6939 (North America,  
Puerto Rico, and Virgin Islands only)

*Facsimile:* 219-294-8301 (Technical Support)  
219-294-8124 (Factory Service)

*Internet:* <http://www.crownaudio.com>

