



20048

CROWN

SERIAL NO. _____

ISSUED TO _____



INSTRUCTION MANUAL

M-600

audio amplifier



The information furnished in this manual does not include all of the details of design, production, or variation of the equipment. It does not cover all the possible contingencies which may arise during operation, installation, or maintenance. Should special problems arise, or further information be desired, please contact the CROWN International Customer Services Department.

CROWN International
1718 W. Mishawaka Rd.
Elkhart, Indiana 46514
PH: (219) 294-5571



TABLE OF CONTENTS

	Page
Section 1. General Information	
1.1 Introduction/Purpose of Equipment	1-1
Section 2. Specifications/Performance	
2.1 General Specifications	2-1
2.2 Specifications (M-600)	2-2
2.3 Specifications (M-2000)	2-4
2.4 Performance	2-6
Section 3. Installation/Operation	
3.1 Unpacking	3-1
3.2 Mounting	3-1
3.3 Connecting Output Lines	3-2
3.4 Connecting Input Lines	3-3
3.5 Connecting Power	3-6
3.6 Controls and Adjustments	3-9
3.7 The Protection Mechanisms	3-10
3.8 Operating Precautions	3-11
3.9 Load Protection Methods	3-12
3.10 The Interlock Connector	3-13
3.11 Cleaning	3-15
Section 4. Theory of Operation	
4.1 General	4-1
4.2 Principles of Bridge Amplifier	4-1
4.3 Block Diagram Circuit Theory	4-1
4.4 Detailed Circuit Theory	4-2
Section 5. Accessories/Options	
5.1 Introduction	5-1
5.2 Standard Plug-In Assembly	5-1
5.3 PA Option	5-3
5.4 CL-1, Current Limiter for Motor Control	5-5
5.5 CCM-1, Constant Current Module	5-7
5.6 Current Sense Adapter	5-9
5.7 Compressor Limiter with Remote Gain Control	5-11
5.8 Bandpass Filter with Bridging Input	5-13
5.9 Very High Purity Sine Oscillator	5-15
5.10 Voltage Controlled Function Generator	5-17
5.11 Multiplying D/A Converter — Unipolar Operation	5-19
5.12 Multiplying D/A Converter — Bipolar Operation (Offset Binary)	5-21
5.13 Multiplying D/A Converter — Bipolar Operation	5-23

TABLE OF CONTENTS, (Continued)

Page

Section 6. Illustrated Parts List

6.1	General Information	6-1
6.2	Standard and Special Parts	6-1
6.3	Ordering Parts	6-1

Section 7. Maintenance

7.1	Introduction	7-1
7.2	Required Test Equipment	7-1
7.3	Other Test Equipment	7-1
7.4	Identifying Parts	7-1
7.5	Establishing Problems	7-3
7.6	Disassembly for Inspection, Service, Testing, Adjustment and Repair	7-3
7.7	General Notes on Reassembly	7-5
7.8	Visual Inspection	7-7
7.9	Electrical Checkout, Troubleshooting and Adjustment	7-7
7.9.1	Turn-On Checkout (No Input Signal and No Load)	7-10
7.9.2	Power Control Module Checkout and Adjustment	7-12
7.9.3	Main Module Checkout and Adjustment	7-12
7.9.4	Meter Module Checkout and Adjustment	7-15
7.9.5	Intermodulation Distortion Checkout	7-16
7.9.6	Noise Level Checkout	7-16
7.9.7	Thermal Protection Checkout	7-17
7.10	Repair Instructions	7-18
7.10.1	Consumable Materials	7-18
7.10.2	Repair of Wiring	7-18
7.10.3	Repair of Printed Circuit Boards	7-18
7.10.4	Replacing Baffles	7-18

Section 8. Service Bulletins

LIST OF ILLUSTRATIONS

Fig. 2-1	M-600 Typical Frequency Response: 2.828 Volts Output	2-6
Fig. 2-2	M-600 Output vs R(Load) at 1 KHz	2-6
Fig. 2-3	M-600 Typical Power Output: 16 Ohm Load	2-7
Fig. 2-4	M-600 Typical Power Output: 8 Ohm Load	2-7
Fig. 2-5	M-600 Typical Power Output: 4 Ohm Load	2-8
Fig. 2-6	M-600 I.M. Distortion	2-8
Fig. 2-7	M-600 Damping Factor	2-8
Fig. 2-8	M-600 Typical Power Efficiency: 120 VAC-Driven to Maximum Undistorted Level at 8 Ohms	2-9
Fig. 2-9	M-600 Percent Total Harmonic Distortion	2-9
Fig. 2-10	M-600 Output Impedance	2-10
Fig. 2-11	M-600 Phase Response	2-10
Fig. 2-12	M-600 Noise Spectrum	2-11
Fig. 2-13	M-600 Typical Limits of VI Output	2-12
Fig. 3-1	Mounting Dimensions	3-1
Fig. 3-2	M-600 Outputs	3-2
Fig. 3-3	Source Resistance and Damping Factors vs Length and Size of Output Leads	3-2
Fig. 3-4	Inductance of Parallel Wire	3-3
Fig. 3-5	Passive L-P Filters	3-4
Fig. 3-6	Active L-P Filters	3-4
Fig. 3-7	Proper Use of Balanced Input with Unbalanced Signal Sources	3-5
Fig. 3-8	High Pass Filters (Butterworth)	3-5
Fig. 3-9	Wein Bridge Notch Filters	3-6
Fig. 3-10	Power Supply Jumper Connections for Various Power Input Voltages	3-7
Fig. 3-11	Peak Sensing Line Voltage Monitor	3-8
Fig. 3-12	M-600 Rear View (Cover Removed)	3-8
Fig. 3-13	M-600 Front Panel	3-9
Fig. 3-14	M-600 Rear View (Cover Removed)	3-10
Fig. 3-15	Fuse Selector Nomograph for Loudspeaker Protection	3-12
Fig. 3-16	Relay Controlled Protector with Overload Indicator	3-12
Fig. 3-17	Precision Signal Limiter	3-13
Fig. 3-18	M-600 Interlock Receptacle (Rear of M-600 View)	3-14
Fig. 3-19	Standard Interlock Plug (Rear of M-600 View)	3-14
Fig. 3-20	M-2000 Interlock Cable (Rear of M-2000 View)	3-14
Fig. 3-21	Voltage Comparator Standby Controller (Rear of M-600 View)	3-14
Fig. 3-22	AC Power Remote Start (Rear of M-600 View)	3-14
Fig. 3-23	Digital Controller Interface (Rear of M-600 View)	3-14
Fig. 3-24	Output Crowbar (Rear View M-600)	3-14
Fig. 3-25	Dust Filter	3-15

LIST OF ILLUSTRATIONS (Continued)

	Page
Fig. 4-1	M-600 Block Diagram 4-4
Fig. 4-2	M-600 Electrical Schematic Diagram 4-5
Fig. 4-3	M-600 Main PC Board Layouts, #7985 and #9579 4-6
Fig. 4-4	M-600 Power Supply Schematic Diagram 4-7
Fig. 4-5	Display Circuit Schematic Diagram 4-7
Fig. 4-6	M-600 Power Supply PC Board Layout 4-8
Fig. 5-1	Pictorial, Standard Plug-In Assembly 5-1
Fig. 5-2	Standard Plug-In Assembly Schematic 5-2
Fig. 5-3	Universal Plug-In PC Board (view from component side) 5-2
Fig. 5-4	Pictorial, Current Sense Adapter Assembly 5-9
Fig. 5-5	Schematic, Current Sense Adapter Assembly 5-10
Fig. 6-1	Covers and Front Duct Panel 6-2
Fig. 6-2	Fan Panel Assembly 6-4
Fig. 6-3	Transformer and Front Panel Assembly 6-6
Fig. 6-4	Power Supply Assembly 6-8
Fig. 6-5	Control Panel Assembly 6-10
Fig. 6-6	Bottom Output Panel 6-12
Fig. 6-7	Top Output Panel 6-14
Fig. 6-8	Duct Back Panel Assembly 6-16
Fig. 6-9	Harness Assembly 6-18
Fig. 6-10	Meter Module 6-20
Fig. 6-11	Input Control Panel 6-22
Fig. 6-12	Main Module Printed Circuit Card 6-24
Fig. 6-13	Power Control Module Printed Circuit Card 6-26
Fig. 6-14	Display Module Printed Circuit Card 6-28
Fig. 6-15	Positive Output No. 1 Printed Circuit Card 6-30
Fig. 6-16	Positive Output No. 2 Printed Circuit Card 6-32
Fig. 6-17	Positive Output No. 3 Printed Circuit Card 6-34
Fig. 6-18	Positive Output No. 4 Printed Circuit Card 6-36
Fig. 6-19	Negative Output No. 1 Printed Circuit Card 6-38
Fig. 6-20	Negative Output No. 2 Printed Circuit Card 6-40
Fig. 6-21	Negative Output No. 3 Printed Circuit Card 6-42
Fig. 6-22	Negative Output No. 4 Printed Circuit Card 6-44
Table 7-1	Required Test Equipment 7-2
Fig. 7-1	Input Power Connections for M-600 Checkout and Troubleshooting 7-6
Fig. 7-2	M-600 Wiring Diagram (Sheet 1 of 2) 7-8
Fig. 7-2	M-600 Wiring Diagram (Sheet 2 of 2) 7-9
Fig. 7-3	M-600 Voltage Test Points 7-11
Fig. 7-4	Waveforms Produced by M-600 with Properly Adjusted Bridge 7-13
Fig. 7-5	M-600 Output and Bridge Balance Operational Amplifier Outputs when Properly Balanced 7-14
Fig. 7-6	M-600 Output Waveform with 10 KHz Square Wave Input and 8 Ohm Load 7-14
Fig. 7-7	Test Setup for Measuring M-600 Intermodulation Distortion 7-16
Fig. 7-8	Setup for Measuring M-600 Noise Level 7-17
Table 7-2	Consumable Materials 7-19



SECTION 1. GENERAL INFORMATION

1.1. INTRODUCTION/PURPOSE OF EQUIPMENT

The M-600 is a high power systems amplifier for precision amplification of frequencies from DC to 20 KHz. It features extremely low harmonic and intermodulation distortion and very low noise. Because of the very large output power, 70V rms audio distribution systems may be driven with no output step-up transformer.

The M-600 as a system amplifier features an interlock of its high power supply which may be interfaced with external controllers and/or other M600 amplifiers. Two amplifiers joined thru the interlock cable and a heavy, output ground-strap can provide a 140V rms balanced output at over 2 KW. Such an ensemble is referred to as a model M-2000.

A front panel plug-in circuit board allows the user to construct various input signal-sources or conditioners to suit individual applications. The standard plug-in contains an input attenuator and an AC-DC coupling mode-switch along with a blank universal layout board.

The output circuitry deploys 32 rugged 150 watt transistors (4800W dissipation) in a CROWN-developed and patented bridge circuit having one end of the load common to ground. This circuit effectively doubles the available output voltage without increasing the operating voltage of the output transistors, resulting in increased reliability since fragile high voltage transistors or series output-circuitry are not required.

Meter lights and a red indicator lamp indicate the presence of AC power. The power switch is of the visually indicating type and engages only the low power supplies and cooling system which in turn control the high power supplies by means of a 50A relay.

A self-contained, forced-air cooling system having a 1900W cooling capacity in 25°C air is employed with a two-speed fan to minimize noise output and dust loading of the input filter at times of low dissipation.

The high power supply contains two 1 KW transformers and computer grade filter capacitors giving 100 joules of energy storage.

The low power supply furnishes ± 15 VDC outputs from a current-limited IC regulator which is also protected with automatic thermal shutdown. Shutdown of this supply simultaneously disables the high power supply.

The unit contains 68 discrete bipolar transistors, 1 FET, 35 diodes, 2 zeners, 2 bridge rectifiers, 2 moxies, 1 dual tracking regulator IC, and 4 dual IC opamps. This results in an effective complement of 257 semiconductors.

The output transistors operate in the CROWN-patented AB+B mode of operation where all quiescent current is carried by the driver transistors. Electronic overload protection is provided in the form of the proprietary Signal Programmed Automatic Current Executor (SPACE controller) which acts as a signal-variable current limiter at audio frequencies and as a VI limiter at low frequencies and DC.

If the unit should overheat due to a cooling system failure, or the line voltage become excessive, the high power supply will be disengaged, placing the unit in the standby mode. The low power supply and cooling system remain on.

On the rear of the unit are switches to engage a 4 - 5 second turn-on delay and a low frequency load-protector if they are desired by the user. Actuation of those systems results in the unit going into the standby mode which is indicated by an amber indicator light located on the front panel.

The panel meter incorporates a full-wave peak catch-and-hold circuit which allows accurate observations of peak output voltage levels. A comparator circuit attached to the output of the peak catch-and-hold circuit controls a pair of level indicator lamps. The red lamp functions as an "excess output" indicator while the green lamp acts as a "signal level adequate" indicator. The red threshold is

switch adjustable to be 0, 3, 6, 10, 15, or 20 dB below full output while the green threshold is switch adjustable to be 0, 3, 6, 10, 15, or 20 dB below the red threshold.



SECTION 2. SPECIFICATIONS/PERFORMANCE

2.1. General Specifications

- General Protection:** High line voltage or over temperature results in shutdown of the high power supplies, each of which is fused. Controlled-slewing-rate voltage amplifiers protect the amplifier against RF burnouts. Input overload protection is furnished by a resistor at the input of the amplifier to limit current.
- High Power Supply:** 2 - 1 KW transformers with computer grade capacitors storing 100 joules are powered through a 50A relay.
- Low Power Supply:** ± 15 Vdc supplies are provided by a current limited shortproof regulator which has automatic thermal shutdown. Supplies are accessible at the input plug-in and interlock connector. Shutdown of these supplies results in shutdown of the high power supplies.
- Power Requirements:** 50-60 Hz AC with adjustable taps for 120, 220, and 240V $\pm 10\%$ operation. Draws 80 W or less on idle, 1KW at 500W output into 8 ohms.
- Displays:** A lighted 4" VU meter is driven by a full wave peak catch-and-hold amplifier having a step response time of less than 10usec to a "0" VU reading. The reading is held for approximately .6 seconds which is adequate time for the meter to fully respond.
- A two threshold level comparator drives two level indicating lamps. The red overlevel lamp may be switch-selected to indicate at 0, 3, 6, 10, 15, or 20 dB below full output. The green operating range lamp may then be switch-selected to indicate the range extending to 0, 3, 6, 10, 15 or 20 dB below the red threshold. An amber neon indicator indicates the standby mode (high power supply deactivated).
- A red neon indicator indicates power on.
- A green mechanical indicator in the power switch indicates switch engaged.
- Controls:** On the meter display are two knobs for adjusting the indicator lamp thresholds.
- Push-Push power switch.
- On the standard input plug-in are an AC-DC input coupling switch and an input attenuator pot.
- The LF Protection and Delay switches are located on the rear panel.

Interlock:	Up to 8 units may be commonly interlocked such that if any one is requesting the standby mode all units will be in standby. The standby mode may be initiated by opening an external common to ground contact of 10V 3ma rating i.e. an open collector high voltage TTL output or an opto isolator output. The ± 15 VDC supplies are available through the interlock connector for supplying interlock peripherals.
Input Plug-ins:	The standard plug-in contains an AC-DC input coupling capacitor and switch, a gain control potentiometer, and a universal PC layout which may be adapted for input peripherals such as: differential inputs, filters, oscillators, servo amplifiers, remote DC gain controls, compressors, digital controllers, etc. Regulated ± 15 VDC supplies are provided with the maximum total available current of the supplies limited to 25 ma. The delay mode of amplifier operation may be programmed from the plug-in.
Connectors:	Standard Input - 1/4 inch phone jack. Special Input - 3 term. barrier strip - routes to input plug-in. Output - Color coded binding posts on standard 3/4" centers. AC Line - Three wire 20A, 120V male connector with 5 ft. min. cable. Interlock - 11 pin "octal" socket.
Construction:	Aluminum chassis with 1/4" thick front panel reinforced with steel to retain the power transformers, 1/8" aluminum side panels. Heavy duty handles on front to ease transport. Plug in circuit boards.
Dimensions:	19" standard rack mount (W.E. hole spacing), 8-3/4" height, 16-1/2" behind mounting surface, handles extend 2" in front of mounting surface. Center of gravity is nearly centered at 5" behind the mounting surface.
Weight:	92 pounds (41.7 Kg) net weight.
Finish:	Bright anodized brushed aluminum front panel with black anodized lower extrusion and black anodized aluminum chassis and covers.

2.2. Specifications (M-600)

R.M.S. Power Response: +1, -0db DC-20KHz at 600W into 8 ohms.
+1, -0db DC-15KHz at 1KW into 4 ohms.

R.M.S. Power at Clip Point: Typically 750W into 8 ohms, 1350W into 4 ohms. (See graphs.)
(Less than .01% THD at 1KHz)

R.M.S.. Burst Power (IHF): Typically 840W into 8 ohms, 1600W into 4 ohms. (See graphs.)

DC Output: Typically 20A maximum (supply fuse limited) at 100V or 2KVA. (See graphs.)



CROWN
M-600

Frequency Response:	± 1 dB DC-20KHz at 1W into 8 ohms. (See graphs.) ± 1 dB DC-100KHz at 1W into 8 ohms. ± 1 dB 10Hz-100KHz at 1W in AC coupled input mode of standard input plug in.
Phase Response:	+0, -15 degrees DC-20KHz at 1W into 8 ohms. (See graph.)
Slew Rate:	16V/usec.
I.M. Distortion: (60-7KHz 4:1)	Less than .05% from .01W to 600W (peak equivalent to a single sinusoid, rms.) into 8 ohms. Less than .01% at 600W into 8 ohms or 1200W into 4 ohms.
Harmonic Distortion: (True RMS Measure)	Less than .05% from DC-20KHz at 600W into 8 ohms.
Output Impedance:	5.5mohms in series with 2.5 uH which are together shunted by 2.7 ohms in parallel with 1 uF. (See graphs.)
Damping Factor: (8 ohms)	Greater than 400 from DC to 1KHz at 1A rms, typically 1500 from DC to 100Hz. (See graphs.)
Load Impedance:	Primarily used at 4 ohms or greater maximum cont. sinusoidal output power at 2.5 ohms, lower impedance affects only maximum power; will drive a completely reactive audio load with no adverse effects. See operating area graph.
Input Gain:	20 \pm 1% (26dB) at standard input with input attenuator fully CW -1 \pm 1% at interlock connector input.
Std. Input Sensitivity:	3.46V rms \pm 1% for 600W rms into 8 ohms.
Input Impedance:	25K \pm 30% with standard input. 44.76K \pm 5% at interlock connector input.
Hum and Noise: (20Hz-20KHz)	120 dB below 600W into 8 ohms. Typically 128 dB unweighted.
DC Drift at Output:	Typically less than 100uV/ $^{\circ}$ C with all inputs grounded.
Heat Sinking:	Forced air with high efficiency coolers (8) which can dissipate 1900W with 25 $^{\circ}$ C intake air at 1 atmosphere. (Dissipation derates to zero at 75 $^{\circ}$ C.) A two speed fan with an intake filter (washable) mounted on the left side of the amplifier forces air thru the coolers and out both the top and bottom of the amplifier.
Turn-On:	May be switch selected for instantaneous or 4-5 seconds of delay after applying power. No dangerous transients.

Low Frequency Load Protection:	May be switch selected to produce shutdown of the high power supply for DC outputs greater than 6V or low frequency outputs greater than 600W at 10Hz and 8 ohms.
Output Transistor Protection:	Short, mismatch, and open-circuit proof; electronic protection operates without flyback pulses, thumps or shutdown.

2.3. Specifications (M-2000)

(Joined pair M600's with balanced output)

R.M.S.Power Response:	+1, -0dB DC-15KHz at 2KW into 8 ohms. +1, -0dB DC-20KHz at 1.2KW into 16 ohms.
R.M.S. Power at Clip Point: (Less than .01% THD at 1KHz)	Typically 2.7KW into 8 ohms, 1.5KW into 16 ohms.
R.M.S. Burst Power (1HF):	Typically 3.2KW into 8 ohms, 1680W into 16 ohms.
DC Output:	Typically 20A maximum (supply fuse limited) at 200V or 4KVA.
Frequency Response:	$\pm .2$ dB DC-20KHz at 1W into 8 ohms. ± 1 dB DC-50KHz at 1W into 8 ohms.
Phase Response:	+0, -20 degrees DC-20KHz at 1W into 8 ohms.
Slew Rate:	32V/usec.
I.M. Distortion: (60-7VHz 4:1)	Less than .1% from 10mW to 2KW (peak equivalent to a single sinusoid, rms) into 8 ohms. Less than .01% at 2KW into 8 ohms or 1.2KW into 16 ohms.
Harmonic Distortion: (True RMS Measure)	Less than .05% from DC-10KHz at 2KW into 8 ohms.
Output Impedance:	20mohms in series with 6uH.
Damping Factor: (8 ohms)	Greater than 140 from DC to 1KHz at 1A rms, typically 400 from DC to 100Hz.
Load Impedance: (Balanced Output)	Primarily used at 8 ohms or greater; maximum cont. sinusoidal output power at 5 ohms, lower impedance affects only maximum power; will drive a completely reactive audio load with no adverse effects. (See operating area graph of M-600 and multiply V out axis by two.)
Input Gain:	$40 \pm 1\%$ (32dB) at standard input with input attenuator fully CW.
Std. Input Sensitivity:	3.16V rms $\pm 1\%$ for 2KW rms into 8 ohms.
Input Impedance:	25K $\pm 30\%$ with standard input.
Hum and Noise:	115dB below 2KW into 8 ohms. Typically 125dB unweighted.
DC Drift at Output:	Typically less than 200uV/ $^{\circ}$ C with inputs grounded.

CROWN
M-600

Hum and Noise:	115db below 2KW into 8 ohms. Typically 125db unweighted.
DC Drift at Output:	Typically less than 200uV/°C with inputs grounded.
Heat Sinking:	See M-600, twice capacity.
Turn-On:	Same as M-600.
Low Frequency Load Protection:	Same as M-600.
Output Transistor Protection:	Same as M-600.
General Protection:	Same as M-600.
Power Supplies:	See M-600, twice capacity.
Power Requirements:	50-60Hz AC with adjustable taps for 120, 220, and 240V±10% operation. Draws 116W or less on idle, 3.8KW at 2KW output into 8 ohms.
Displays:	Same as M-600 except only one unit has a meter level indicator package. The second unit has a blank panel in its place.
Controls:	Same as two M-600's except for above mentioned display complement. Both units come with a standard input plug-in; however, only one is used.
Interlock:	Same as M-600. Both units are commonly interlocked.
Input Plug-Ins:	Same as two M-600's. Only the master unit uses its plug-in however. If the unit without the display is used as the master unit the total available ±15VDC supply current to the input plug-in becomes 50ma.
Connectors:	Same as M-600.
Dimensions:	Same as two M-600's. If the units are racked above one another a minimum rack spacing of 1-3/4" should be allowed between the units for air discharge.
Weight:	184 pounds (83.5Kg) net weight.
Finish:	Same as M-600.

2.4 Performance

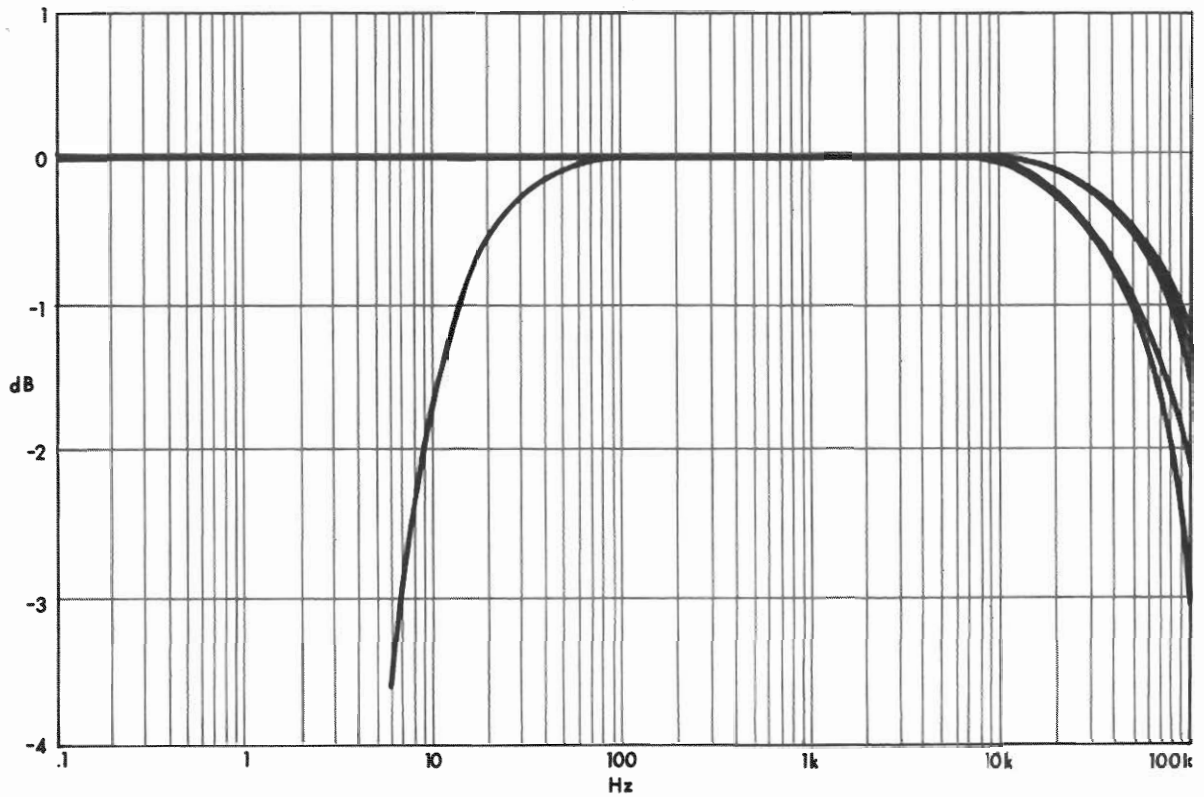

NOTES:

1. For Curve Identification: Start at 100KHz, Top Curve
2. First Curve No Load
3. Second Curve 16 Ohm Load

4. Third Curve 8 Ohm Load
5. Fourth Curve 4 Ohm Load
6. Fifth Curve 8 Ohm Load (Atten. Set at -6 -W/C)
7. *AC Input Coupling

Fig. 2-1. M-600 Typical Frequency Response: 2.828 Volts Output

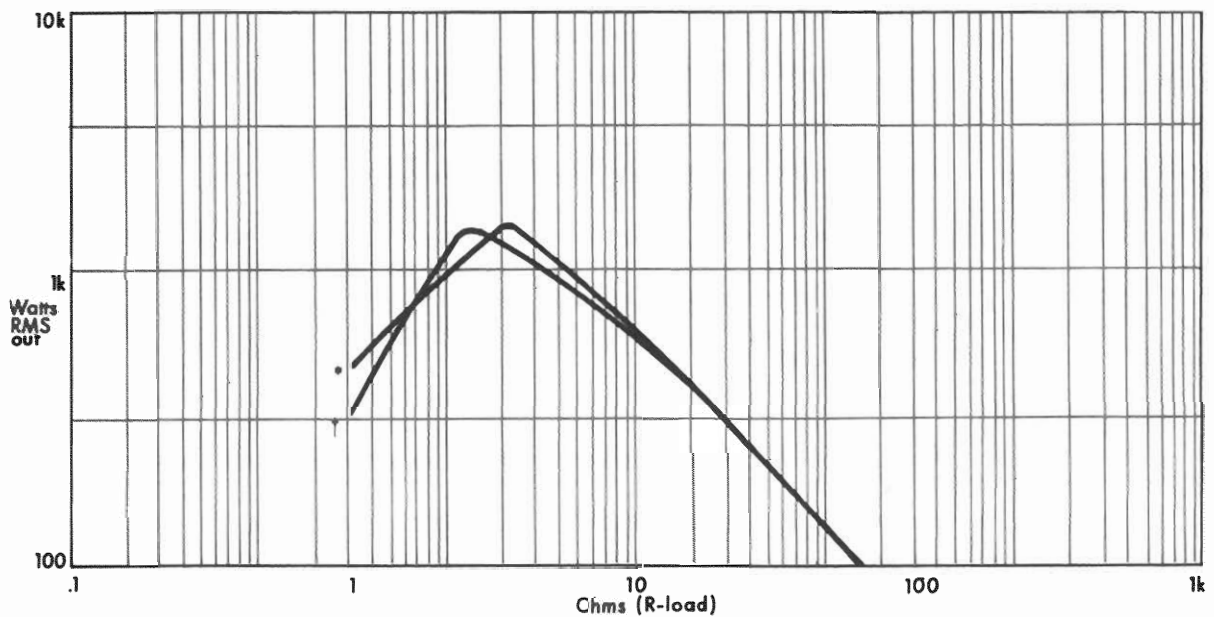

NOTES:

1. *—Continuous
2. †—Tone Burst

Fig. 2-2. M-600 Output vs R (Load) at 1 KHz

CROWN
M-600

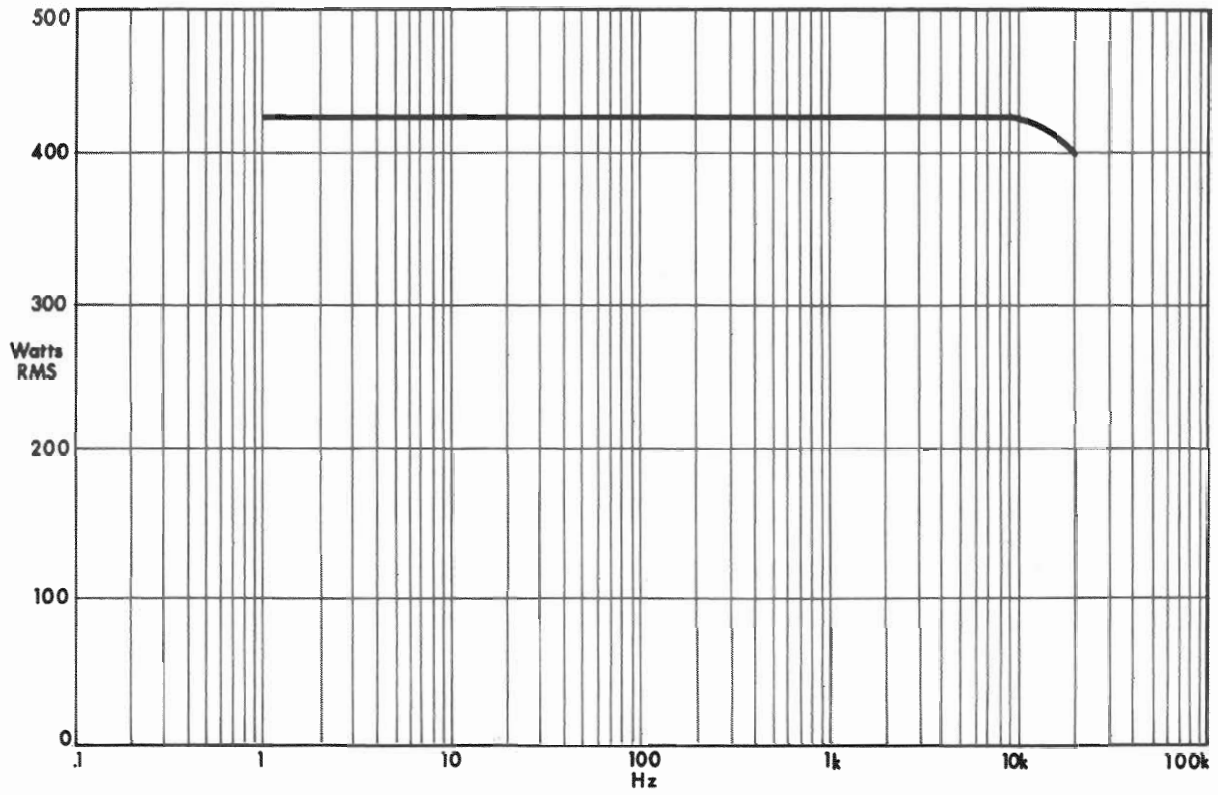

Fig. 2-3. M-600 Typical Power Output: 16 Ohm Load

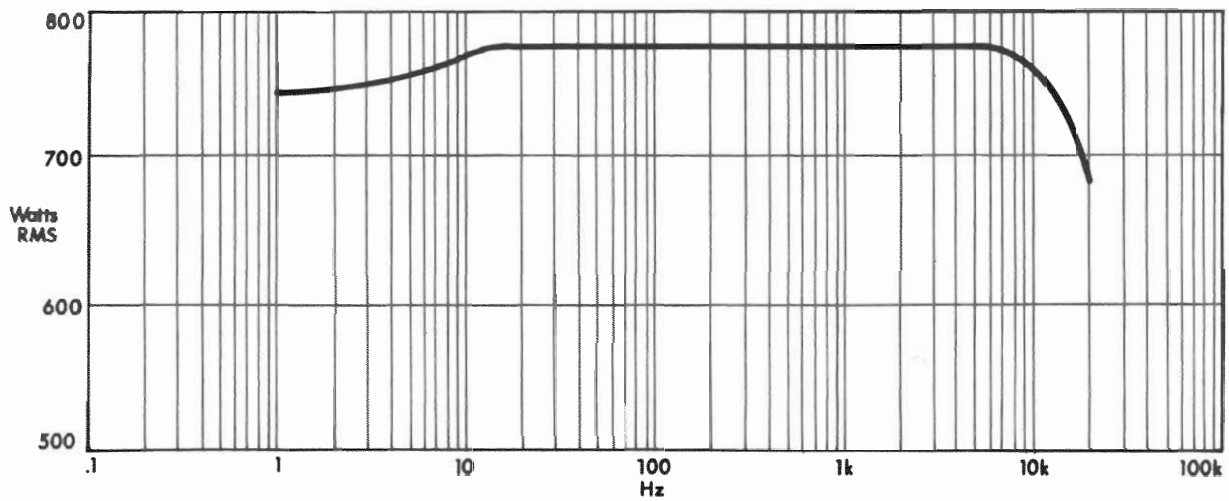

Fig. 2-4. M-600 Typical Power Output: 8 Ohm Load

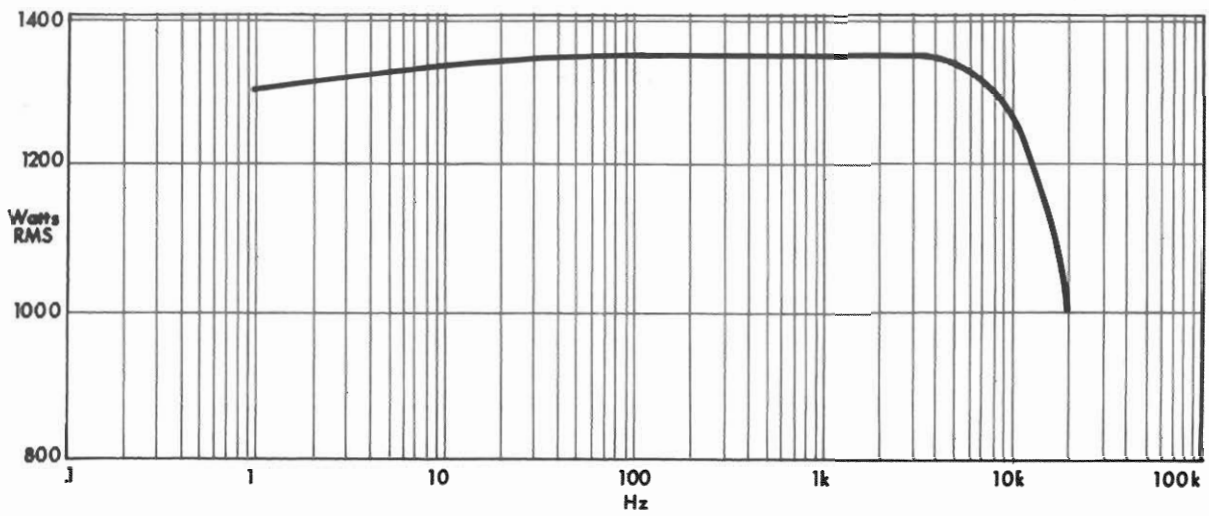
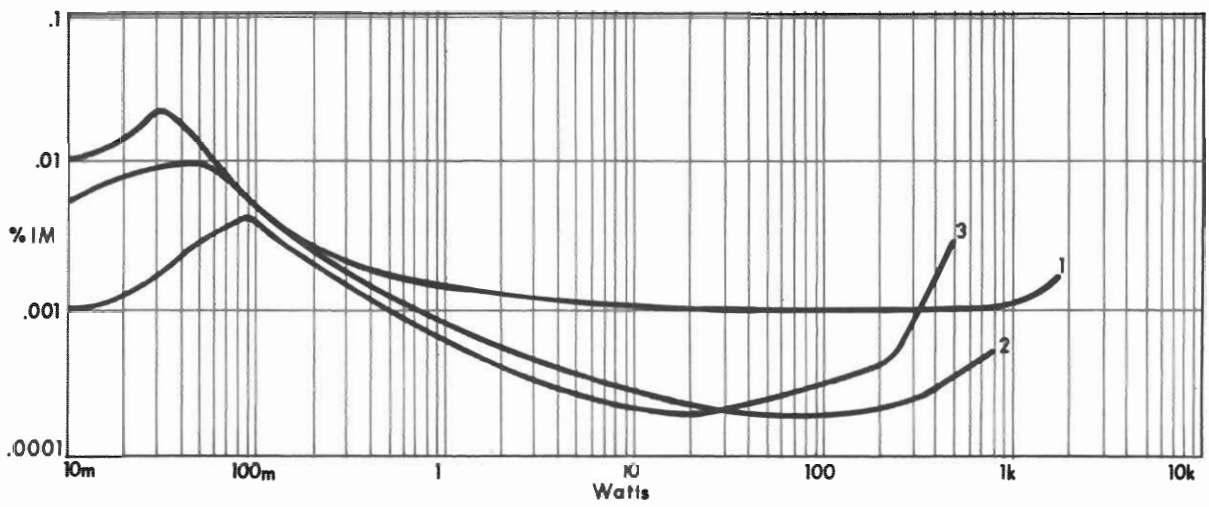
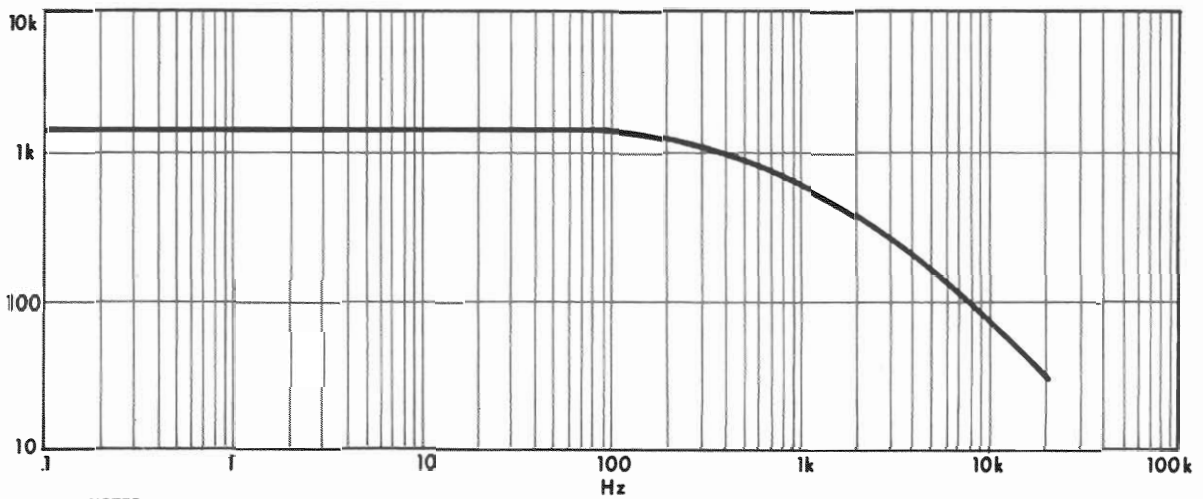

Fig. 2-5. M-600 Typical Power Output: 4 Ohm Load



NOTES:
 1. Curve 1 — 4 Ohm Load
 2. Curve 2 — 8 Ohm Load
 3. Curve 3 — 16 Ohm Load

Fig. 2-6. M-600 I. M. Distortion



NOTES:
 1. 8 Ohm Load — 1 Amp Test Level

Fig. 2-7. M-600 Damping Factor

CROWN
M-600

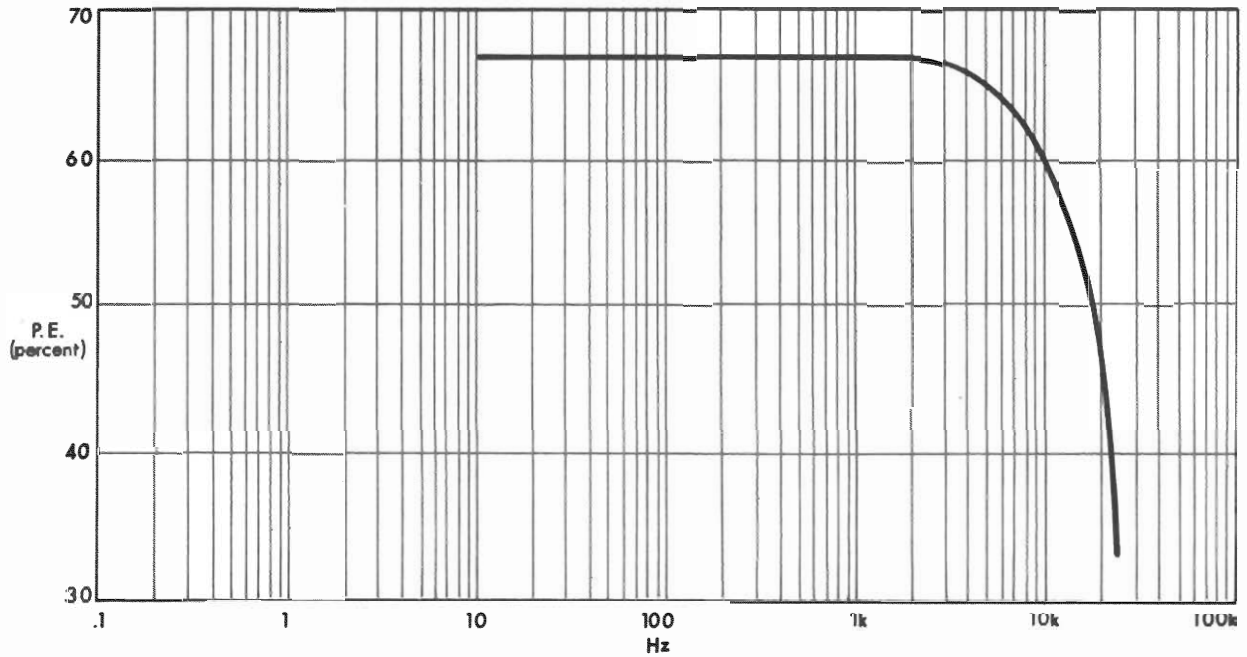

Fig. 2-8. M-600 Typical Power Efficiency: 120 VAC-Driven to Maximum Undistorted Level at 8 Ohms

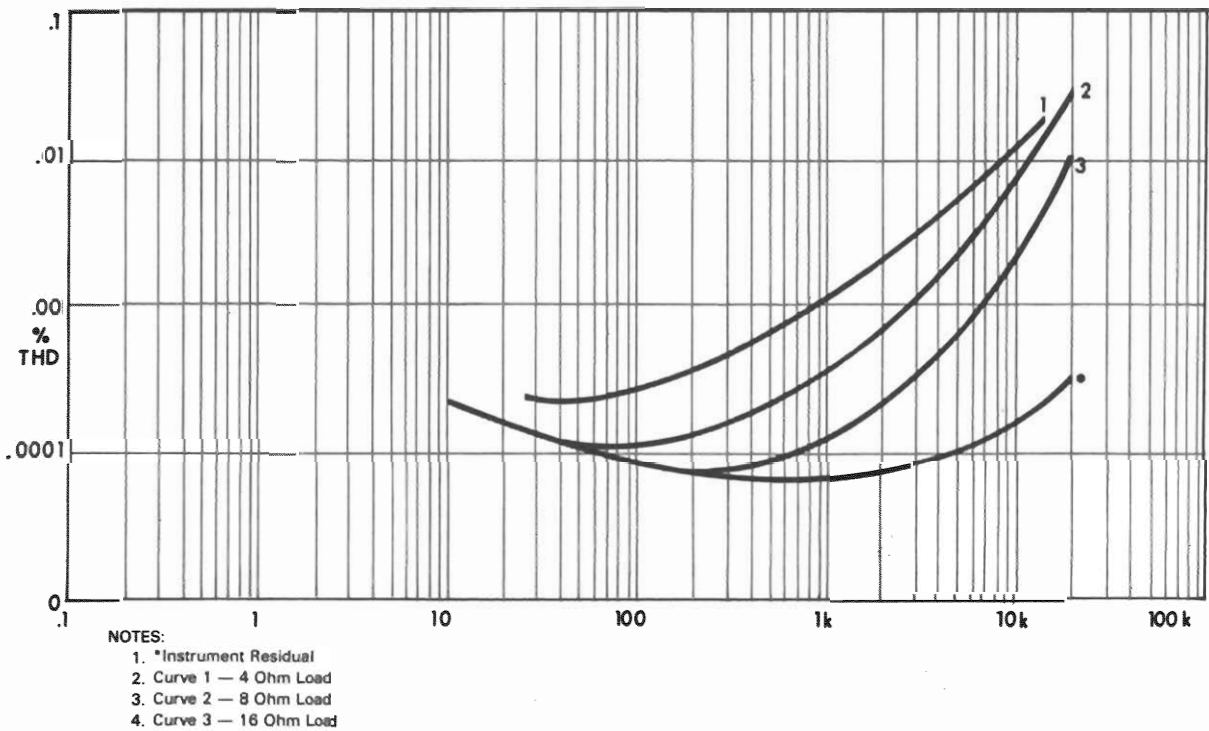

Fig. 2-9. M-600 Percent Total Harmonic Distortion

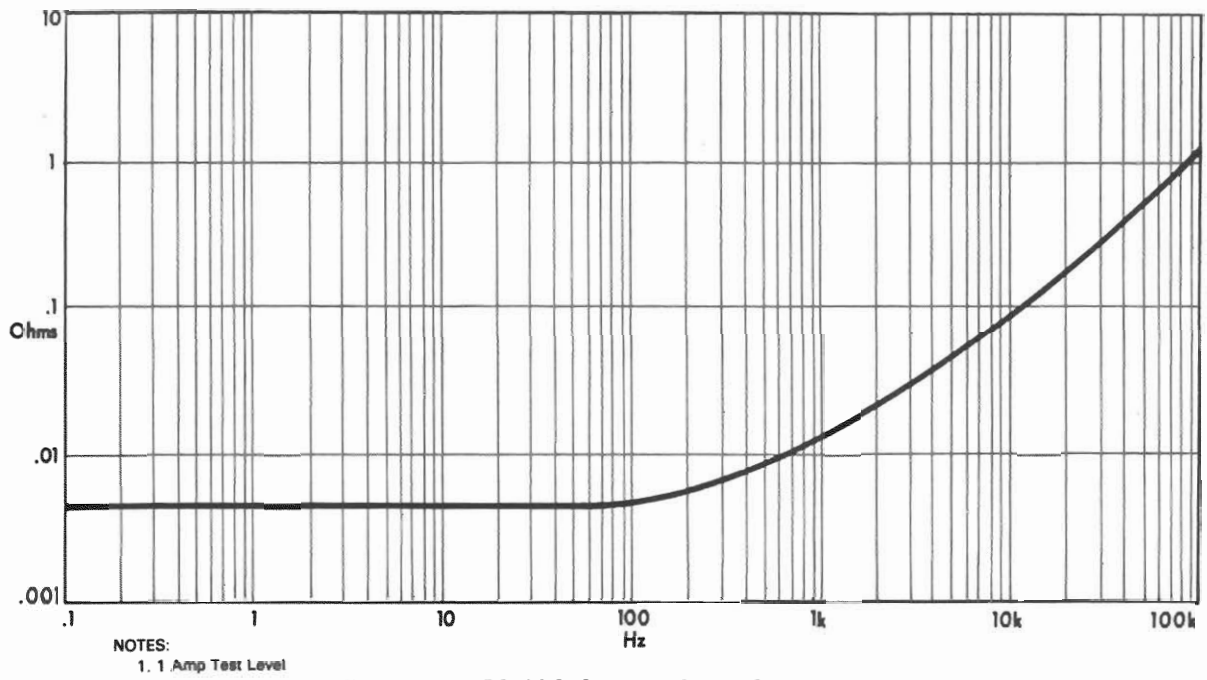
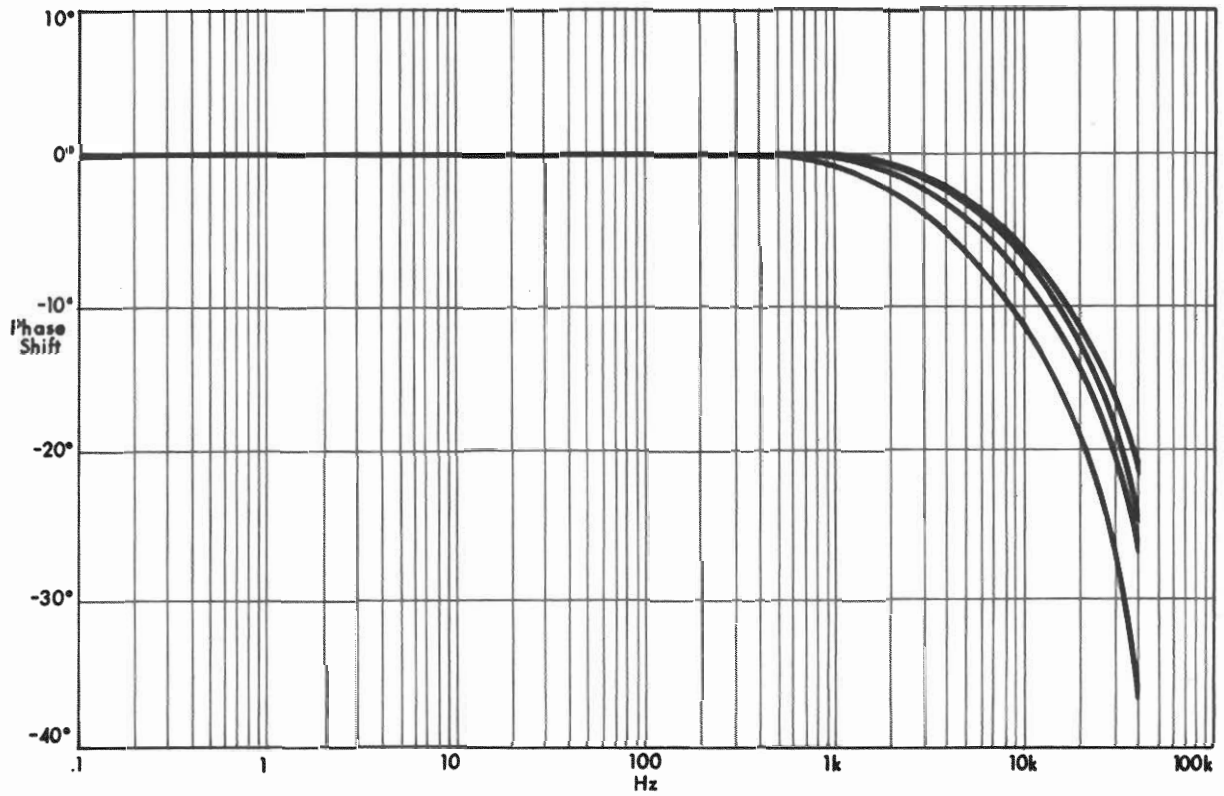

Fig. 2-10. M-600 Output Impedance



- NOTES:
1. Curve 1 — Open Ckt and 16 Ohm Load
 2. Curve 2 — 8 Ohm Load
 3. Curve 3 — 4 Ohm Load
 4. Curve 4 — Input Atten. Set to -6 : 8 Ohm Load (Worst Case)
 5. Effective Signal Delay $T_d=1.5$ μ SEC — Open
 6. =1.6 μ SEC — 16 Ohms
 7. =1.7 μ SEC — 8 Ohms
 8. =1.9 μ SEC — 4 Ohms
 9. =2.6 μ SEC — Worst Case
 10. Output 2.828 Volts All Loads

Fig. 2-11. M-600 Phase Response

CROWN
M-600

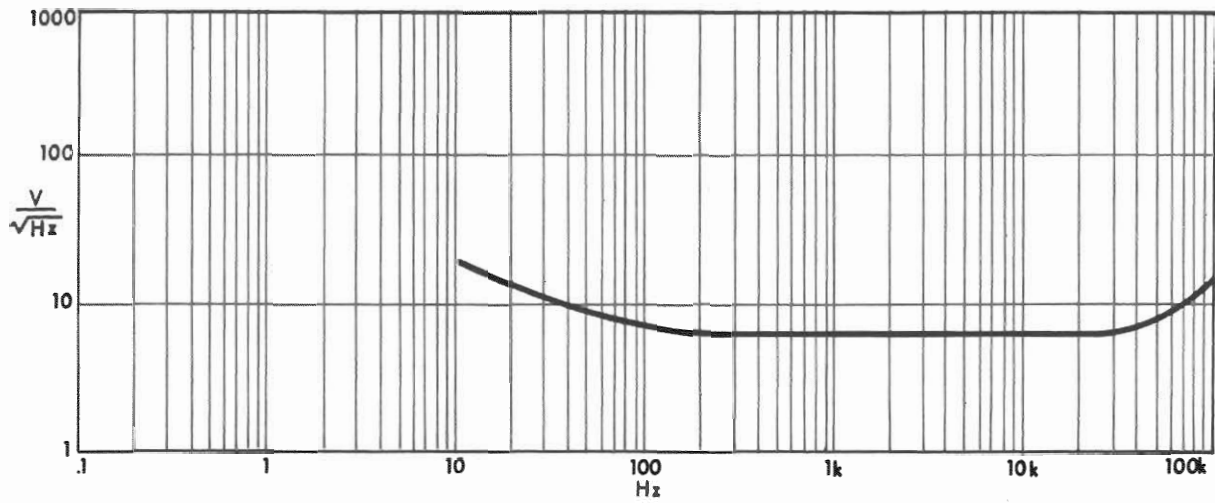

- NOTES:
1. Vertical Scale Calibrated in nV/\sqrt{Hz}
 2. Spectrum Total is Equivalent to 1.7 μV Input
 3. Noise Over a 20Hz to 20KHz Bandwidth

Fig. 2-12. M-600 Noise Spectrum

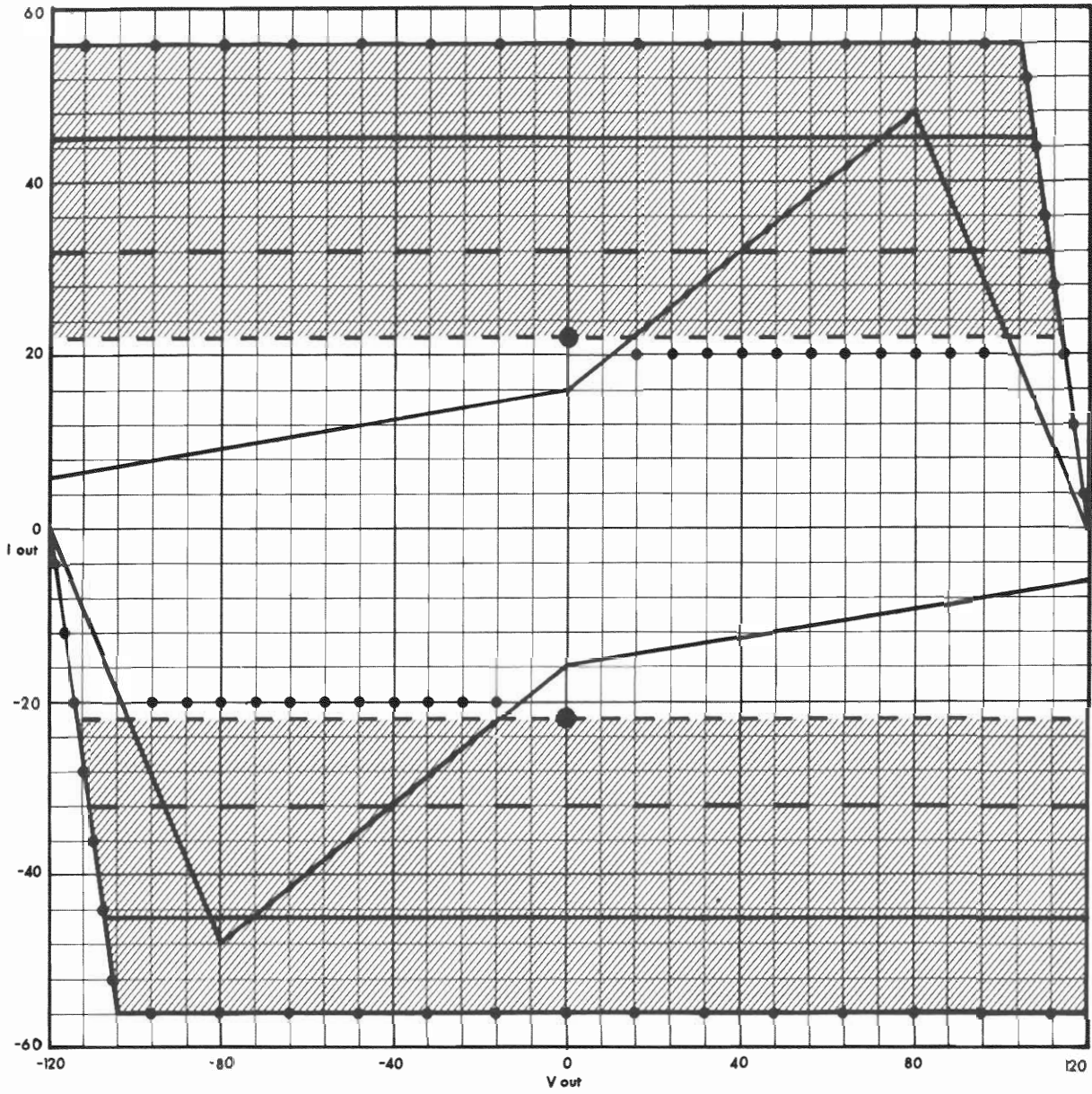

- AC LINE FUSE BLOWS
- MID-FREQ. BURST LIMIT
- SHORT CIRCUIT CONTINUOUS LIMIT
- MAX. AC LIMIT (Z_L , V OUT (SINE) AT MAX.)
- MAX. CONT. AC POWER ($Z_A = 2.75$ OHMS)
- MIN. A.C. LIMIT (Z_L AT MIN.)
- AREA OVER WHICH LIMITER (AC) VARIES (SIGNAL DEPENDENT)

NOTE: FJR M-2000 MULTIPLY V_{OUT} AXIS BY FACTOR OF 2 (TWO).

Fig. 2-13. Typical Limits of VI Output

SECTION 3. INSTALLATION/OPERATION

3.1. Unpacking

As soon as the amplifier shipment is received, please inspect for any damage incurred in transit. Since the unit was carefully inspected and tested at the factory, it left the factory unmarred. If damage is found, notify the transportation company immediately. Only the consignee may institute a claim with the carrier for damage during shipment. However, CROWN will cooperate fully in such an event. Be sure to save the carton as evidence of damage for the shipper's inspection.

Even if the unit arrived in perfect condition - as most do - it is advantageous to save the packing materials. They will prove valuable in preventing damage should there ever be occasion to transport or ship the unit. Note the carton and internal pack - each is designed for protection during transit. **Do not ship the unit without this factory pack!**

Be sure to return the warranty registration form to the factory within ten days for the full warranty coverage.

3.2. Mounting

The M-600/M-2000 is designed on a standard 19 inch rack mounting format. If the rack is to be subjected to portable or other usages likely to result in mechanical shock to the rack, additional internal support should be provided to prevent rack damage.

The simplest form of support is to use chassis supporting angles joined to the side of the rack which support the amplifier from beneath. If chassis slides are used, care should be taken to avoid toppling the rack when the slides are extended. The center of gravity of the amplifier is approximately five inches behind the front panel.

Mounting in any structure of less constructional integrity than an industrial rack requires the construction of a supporting structure or shelf under the amplifier.

If a number of units are being racked on electrically common rails and a very high S/N ratio is to be main-

tained the inputs should be independent in that all the input commons should not be joined together if they are common to chassis, as is the standard input, since AC potentials would typically appear throughout the rack, creating ground loops. There are three basic alternatives in this situation:

1. Use a bridging or differential input on each of the amplifiers.
2. Use a multiplicity of signal sources, one per amplifier.
3. Separate the chassis grounds of the units by insulating the units from the mounting rails.

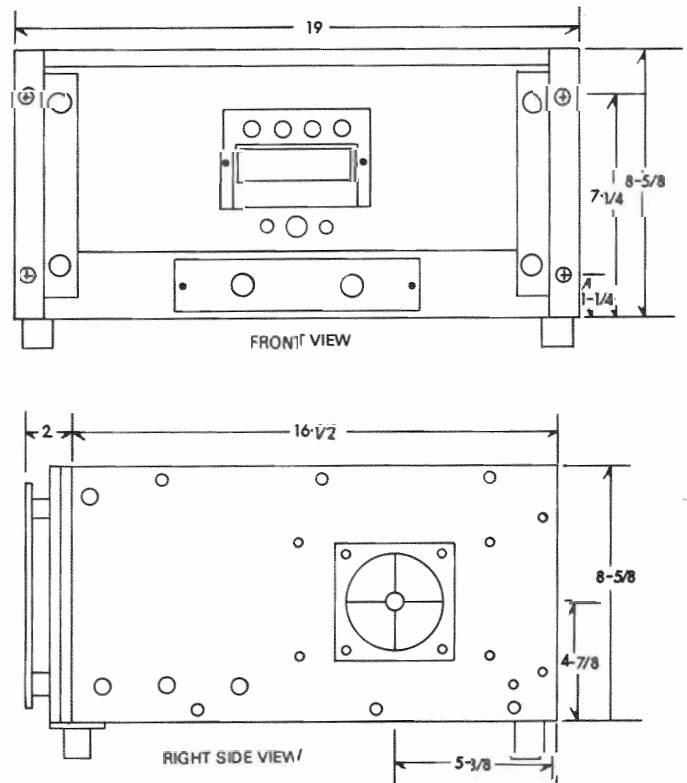

Fig. 3-1. Mounting Dimensions

A minimum rack clearance of 1-3/4" should be allowed above and below the unit for hot air discharge. If M-600's are mounted above one another as would be typical of an M-2000 a 1-3/4" minimum spacing should be allowed between units. If the 1-3/4" clearance rule is followed it will usually not be necessary to remove the rubber feet from the bottom of the unit which extends below the 8-3/4" standard rack height. Should the feet need to be removed, two oval head screws are provided to replace the front feet screws.

A source of cooling air should be provided for the fan intake. In some cases a vent tube to the outside of the rack may be required if the rack ventilation is poor and/or the amplifier heat output is high. In no case should the unit be contained by a small sealed box because automatic thermal shutdown will occur if the unit is operated for any period of time.

If the air supply is unusually dusty it may be desirable to prefilter the air supply using commercial furnace filters, etc. to prevent rapid loading of the unit's own air filter. If the unit's filter becomes plugged it can be cleaned with mild soap and water; replacement is not necessary.

3.3. Connecting Output Lines

The M-600 output connector is located on the rear of the amplifier as shown in Fig. 3-2. In the case of the M2000 the principal output is taken between the red binding posts of both units. In either case the output potentials can be hazardous and connections should only be made with power and input signals removed from the unit!

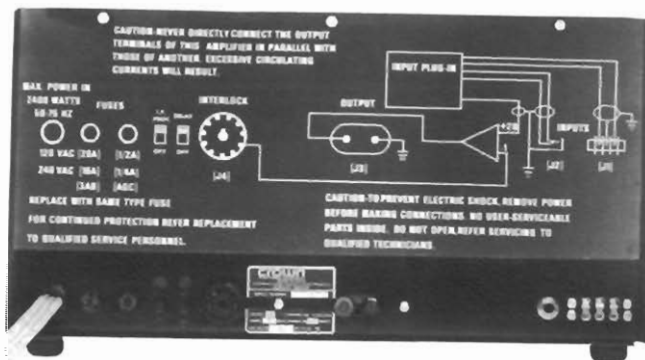

Fig. 3-2. M-600 Outputs

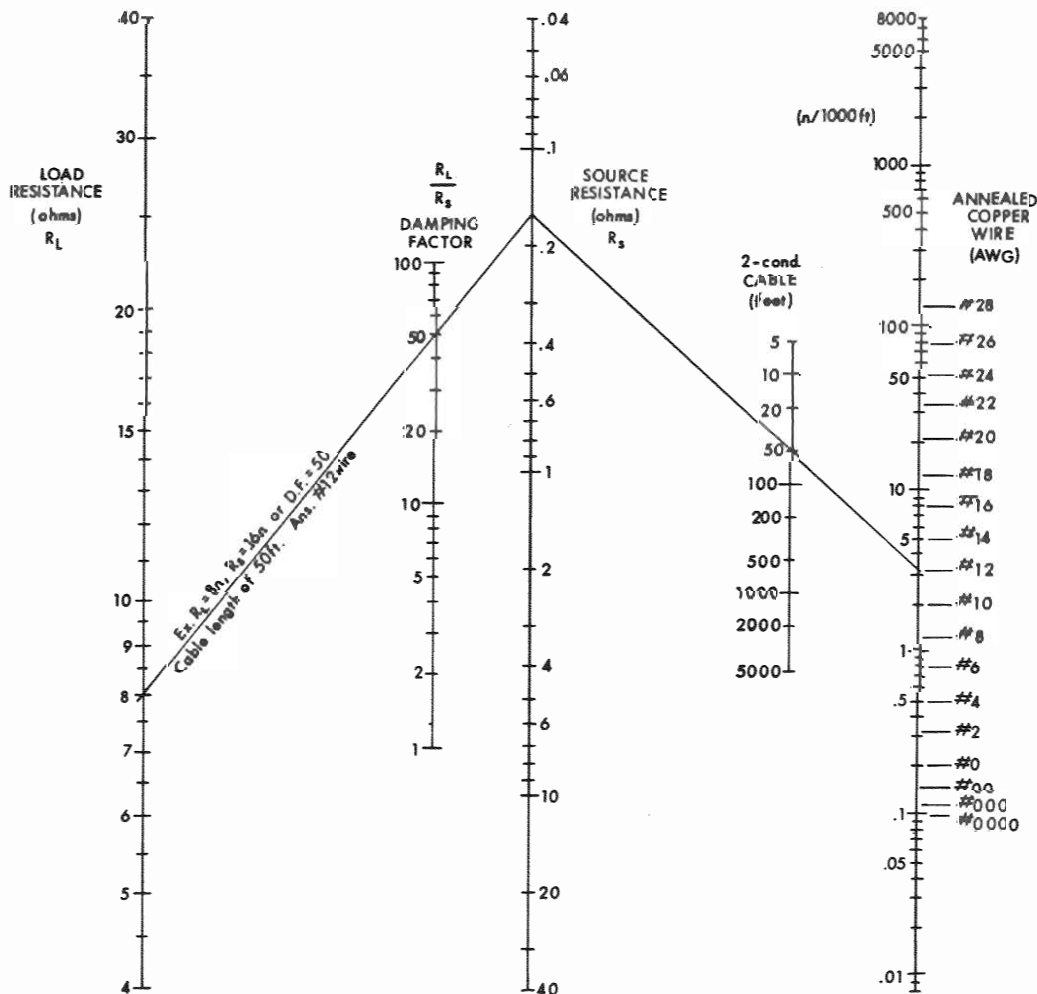

Fig. 3-3. Source Resistance and Damping Factors vs Length and Size of Output Leads

Output cables should always be carefully laced together so that large magnetic fields are not formed, resulting in current carrying loops. Such fields often will couple the input signal path and result in undesired feedback and oscillations. Of course, the output cables should never be routed with input cables for the same reason.

Amplifier input and output grounds should never be joined external to the unit. Such a connection is almost always a form of regenerative feedback and results in system oscillations. High frequency coupling between output signals and input grounds and signals is frequently difficult to eliminate. A common cause of this problem is capacitive coupling through the AC mains where the output and input signals are attached to AC powered devices. In some situations the only solution may be to low pass filter the input at the amplifier.

Output cabling must be of sufficient wire gauge to support the output current without excessive overheating, power loss, or increase in output impedance. The increase in output resistance (or decrease in damping factor as audio systems prefer) is shown in Figure 3-3. The effects of parallel 2 wire cable on output inductance is shown in Figure 3-4. The most typical output cabling would be #12 duplex primary wire.

Output connectors should be of such a type as to reliably handle the unit's output current. A preferred connector is a dual banana (MDP) plug. Care should then be taken that the connector is kept tight as frequent plugging and unplugging loosens these connectors.

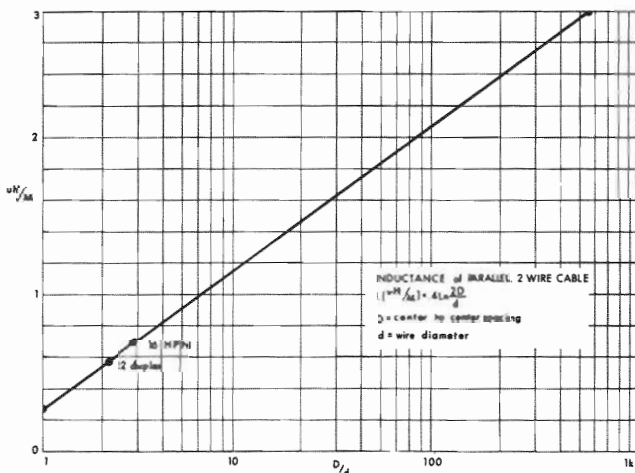

Fig. 3-4. Inductance of Parallel Wire

3.4. Connecting Input Lines

Due to the versatility of the input plug-in the number and nature of the input signals may be greatly varied. The following remarks refer specifically to the standard input plug-in; however, the principles discussed will be relevant to special cases, but of varying degree.

Ground loops producing hum and noise are one of the most common problems and while the solution to them is theoretically trivial, the practical implementation often is not trivial. Theoretically, ground loops will never occur if one and only one ground path (circuit) is allowed between any two device grounds. The input and output grounds of the amplifier, while they are internally joined, should not be externally joined since this would provide a second ground path forming a loop with the internal path. The output ground is connected to the chassis on the rear connector panel; thereby, allowing the chassis mounting to be a possible source of ground loops if other devices attached to the amplifier inputs and outputs are mounted in an electrically common rack and are likewise internally chassis-ground joined. A circumstance such as this requires the isolation of the most appropriate units from the rack so that a loop is not formed.

Another likely source of a ground loop is the third wire of the AC power connector. Only one piece of equipment in a system should deploy this terminal where the terminals are tied to the system's signal ground.

Transducers may have their electrical common tied to their mountings. If so the mounting should be insulated from ground structures providing they are not the only building on earth grounds. In sound systems an FM antenna will frequently be grounded to the structure upon which it is mounted. If the FM tuner has its antenna input chassis grounded, the antenna should be low-frequency decoupled by inserting capacitors in series with the lead-in wires (i.e. .01uF ceramic discs).

Unintentional feedback of output signals into input signal lines can result in system oscillations, or gain errors.

Input signals should never be supplied to the amplifier via the current carrying output common lead except in the case of driving the unity gain inverting input as in the case of an M-2000 interconnection. In this case the ground

to ground strap should be kept short and heavy. Under normal circumstances, input signals should be supplied to the standard input via their own independent ground lead which is in no external way connected to the output signal circuits.

The AC power lines frequently form a high frequency feedback path between input and output devices which are powered by the mains. The amplifier itself couples the mains due to its floating supply-lead grounded bridge circuit which couples some output signal back to the AC mains through approximately 200PF. For this reason it is advisable that the third wire ground of the amplifier be connected, in preference to any other system-earth ground. It is always desirable that AC mains coupling be minimized in devices coupling to the output signals.

If oscillations are present the typical result is excess amplifier and load heating. Sometimes a hum will accompany a meter deflection which will vanish suddenly as the input level is turned down. If a system has multiple level controls the output to input feedback loop causing the oscillation will enclose the level control closest to the input which controls the oscillation. Multiple loops may be present.

If it is not feasible to eliminate the feedback path the high frequency system gain may be reduced by deploying a lowpass filter of the amplifier's input. Such a filter may be built on the standard input plug-in board or may be purchased in the form of the PA plug-in board.

Filters built on the input plug-in may be either of the passive or active type. Figure 3-5 shows three designs for passive Butterworth filters (maximally flat f-resp.). The appended values are for a 3db cutoff frequency of 15KHz. Component values for other frequencies can be computed by means of the formulas given.

Inductors used to construct these filters should have a cutoff frequency Q of 10 or more and be of low external magnetic field pickup type. Toroidal construction is preferred.

Active low pass filters may be constructed on the standard input plug-in card. Figure 3-6 depicts the most popular form for 2 and 3 pole Butterworth types. As in Figure 3-5 15KHz component values and equations are provided. As an example of PC board layout, see the appendix for the schematic and a possible layout for the do-it-yourself construction of a PA adapter. This schematic also shows the employment of a balanced input (differential on bridging type) circuit.

If system instability is being caused by high frequency signals being produced along the common (ground) of the

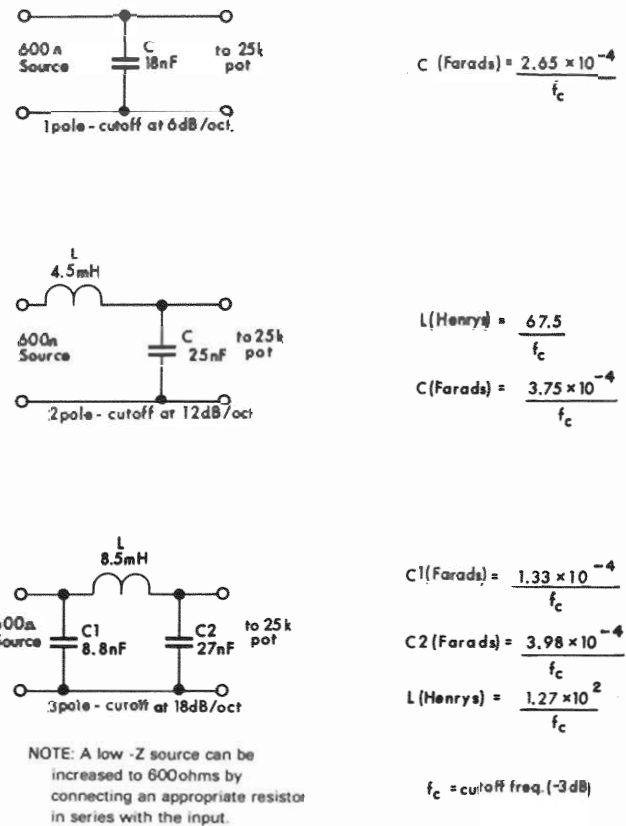

Fig. 3-5. Passive L-P Filters

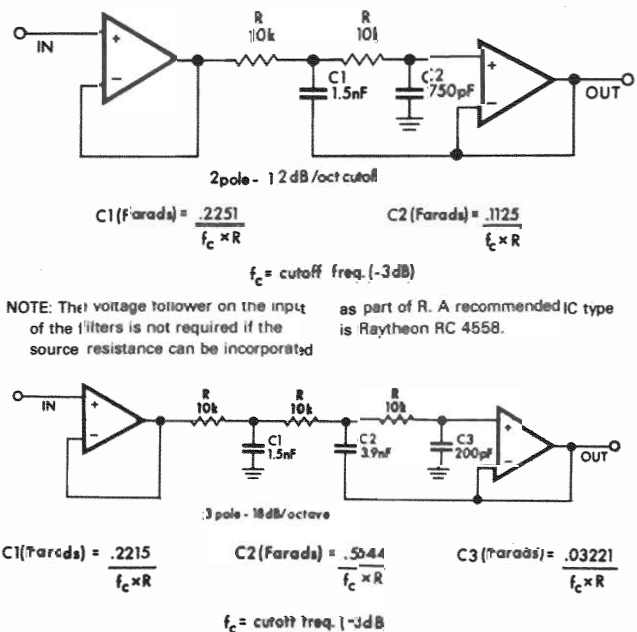

Fig. 3-6. Active L-P Filters

input cabling between the signal source (unbalanced) and amplifier the problem may be alleviated by using a balanced input amplifier and cabling as shown in Figure 3-7.

Note that any potential differences between the signal source and amplifier grounds will appear as a common

mode signal at the balanced input and produce no net input to the power amplifier.

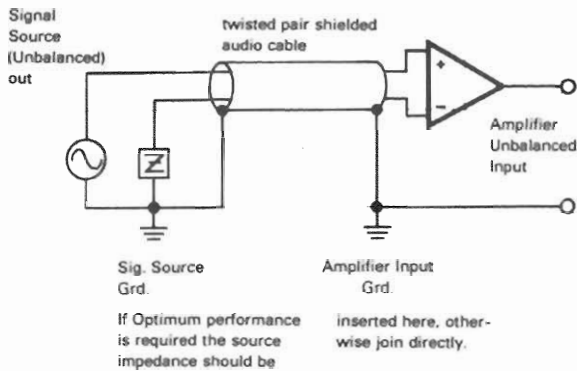

Fig. 3-7. Proper Use of Balanced Input with Unbalanced Signal Sources

Low pass filters are useful for much more than preventing system oscillations. Should ultrasonic or RF input signals which would either damage a load or slow rate jam the amplifier be present, they may be appropriately subdued with a low pass filter.

High pass filters are similarly useful if a load is being overdriven with a low frequency signal. The simplest high pass filter is a capacitor in series with the input (i.e. C500 of the standard input plug-in). Active filters should be used if a good sharp cutoff characteristic is desired. Figure 3-8 shows the discussed filters and their responses. Formulas are given and typical component values for a cutoff frequency f_c of 30Hz.

Should discrete frequencies such as AC mains frequency hum contaminate the input signal a band reject or notch filter may be used to improve the signal to noise without limiting the overall bandwidth. Figure 3-9 shows an adjustable Q, Wien bridge circuit. The component values shown are for a notch frequency of 60Hz and Q of 10. Q's as high as 100 and 1000 have been realized at 1KHz and 60Hz respectively. Such high Q's are not recommended since the stability of notch depth is greatly degraded.

Cascaded notch filters are frequently needed to reject signals such as AC mains hum since substantial harmonics of the fundamental frequency are usually

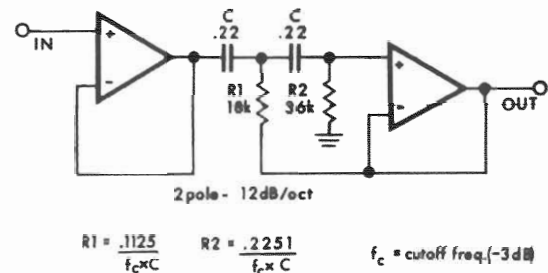

NOTE: The voltage follower on the input of the filters is not required if the source impedance at f_c is much less than $.159/f_c \times C$.

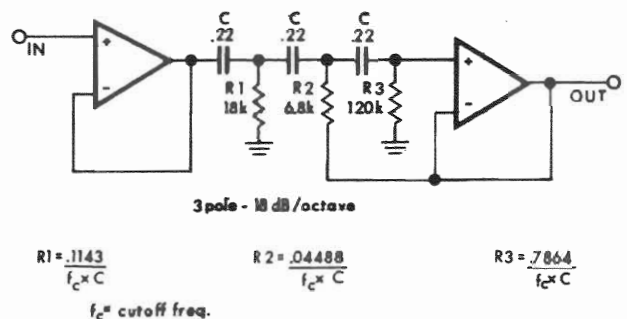

Fig. 3-8. High Pass Filters (Butterworth)

For design details concerning more elaborate filters, consult the following references:

1. "Operational Amplifiers" by Tobey, Graeme, and Huelsman - McGraw Hill 1971.
2. "Active Filters: Lumped, Distributed, Integrated; Digital, and Parametric" by Huelsman - McGraw Hill 1970.
3. "Active Inductorless Filters" by Mitra - IEEE Press 1971.
4. "Modern Filter Theory and Design" by Temes, and Mitra - J. Wiley 1973.
5. "Analysis and Synthesis of Linear Active Networks" by Mitra - J. Wiley 1969.

6. "Theory and Design of Active RC Circuits" by Huelsman - McGraw Hill 1968.

7. "The State Variable Active Filter Configuration Handbook, 2nd AD." by Estep - Estep Enterprises 1974.

8. "Analog Techniques for Filter Simulation" by Bridgeman EAI applications ref. library 8.411a

The amplifier power supplies offer multiple connections for operation at different line voltages. The serial plate indicates for which voltage the amplifier was factory-wired. The application of an AC voltage more than 10% above the indicated voltage will result in automatic removal of power from the high voltage supplies, placing the unit in the "standby" mode.

Converting from one voltage connection to another is a complex operation and should be attempted only by a competent technician. The high-voltage supplies use dual power transformers which must be wired identically. Failure to properly wire the primaries can result in transformer damage should the transformer not share the load properly.

NOTE

The conversion involves two power supplies - a high voltage supply and a low voltage supply. Since different transformers have been used in several production batches, careful identification is imperative. The transformers have the CROWN part number stamped into the top end bells, for convenient identification.

In order to change the voltage, it is first necessary to disconnect power and to remove the top and bottom covers from the unit. (Caution - the main supplies often remain charged for several minutes). The voltage connections are made with push-on connectors and terminal strips.

After the correct operating voltage has been chosen, and all the primary leads identified, the conversion can be performed following the correct drawing of Figure 3-10 and the power supply schematic in Section 4. The drawings in Figure 3-10 are presented chronologically according to production. Notice the three possible transformer combinations. Also note that the three combinations all offer different combinations of operating voltage connections.

When testing the amplifier, the line voltage must be the peak equivalent to a sinusoid of the indicated line voltage when at full load. Line regulation problems can introduce a substantial reduction in the available output power on an amplifier of this size.

Voltages above 150V (120V connection) or 300V (220 or 240V connection) are potentially damaging to the ±15V monolithic dual tracking regulator and are to be avoided.

If the line voltage connection is converted from 100/120VAC to 200/220/240VAC or vice-versa, the over-voltage adjustment (R414) found on the power supply control module (a small board at the rear of the unit) should be readjusted. This readjustment requires a variac and voltmeter. If a peak sensing line voltage:

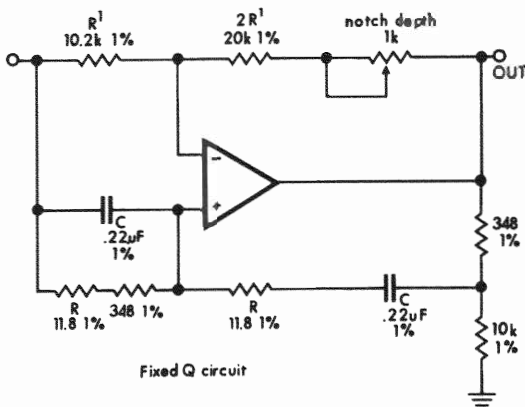

Fixed Q circuit
 $f_n = \text{notch freq.} = \frac{.1592}{(R+348)C}$

NOTES:

1. The two R's may be variable and ganged for frequency tuning.
2. R's and C's should be of high stability types. Metal film and polycarbonate or polystyrene respectively. They should be matched to within 1%.
3. A recommended IC type is Raytheon RC4558.

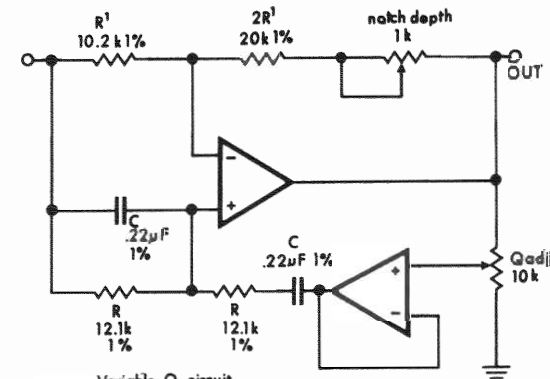

Variable Q circuit
 $f_n (\text{notch freq.}) = \frac{.1592}{R \times C}$; $Q = \frac{1}{3(1-\alpha)}$; $\alpha = \text{pot ratio}$

Fig. 3-9. Wein Bridge Notch Filters

3.5. Connecting Power

The amplifier is furnished with a three-wire 20A, 120V AC plug as standard equipment. Should another type of connector be required, the standard plug should be removed and the desired type installed (which should have an integral cable strain-relief).

The third wire ground should be used with caution since it may introduce a ground loop in a system (read sections 3.2, 3.3, and 3.4).

Power must be 50 or 60 Hz AC. Operation at 400 Hz is not possible since the cooling fan motor becomes inoperative!

CROWN
M-600

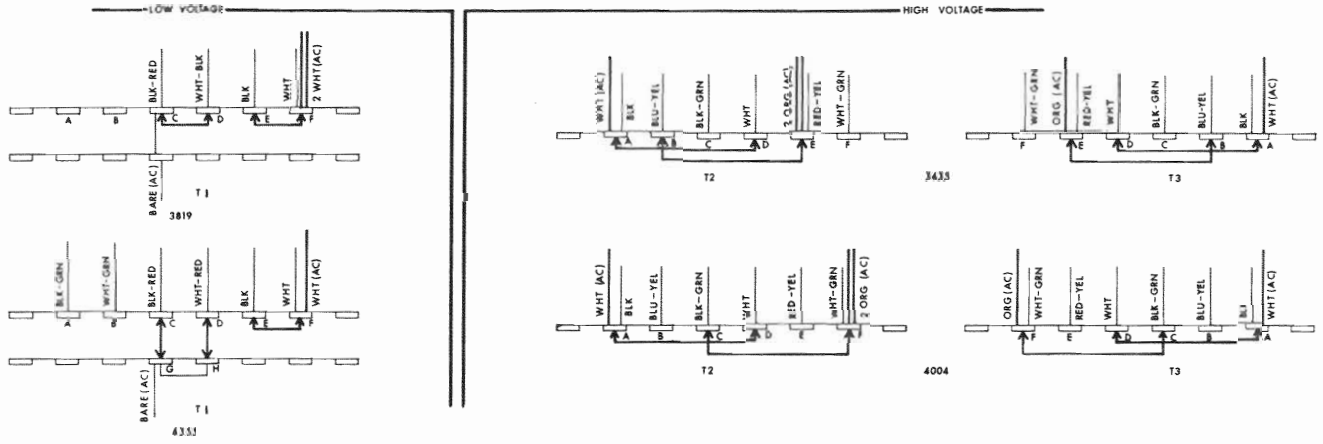

OPERATING VOLTAGE	3435	3819	4004	3819	4004	4355
	Jumpers	Jumpers	Jumpers	Jumpers	Jumpers	Jumpers
100					A-D / B-E*	A-G/B-H/E-F
120	A-D / B-E*	C-D / E-F	A-D / C-F**	C-D / E-F	A-D / C-F**	C-G/D-H/E-F
128	A-D / C-F**	Same as 120V				
200					B-D*	A-G/B-E
220			C-D*	Same as 240V	C-D*	A-G/D-E
240	B-D*	D-E	C-D**	D-E	C-D**	C-G/D-E
248	C-D*	Same as 240V				
256	C-D**	Same as 240V				

LEGEND FOR TABLE:

- Improper operation for this transformer combination.
- Not available.
- * — For T2, move two ORG (AC) wires to E with RED/YEL wire.
For T3, move one ORG (AC) wire to E with RED/YEL wire.
- ** — For T2, move two ORG (AC) wires to F with WHT/GRN wire.
For T3, move one ORG (AC) wire to F with WHT/GRN wire.

NOTES: — All drawings above illustrate connection for 120VAC.
 — Convert for operation at another line voltage by reconnecting jumpers and/or ORG (AC) wires as in table
 — The high-voltage supply is viewed from the front with bottom cover removed.
 — The low-voltage supply is viewed from the front with top cover removed.

Fig. 3-10. Power Supply Jumper Connections for Various Power Input Voltages

monitor such as Figure 3-11 is not available a DC voltmeter reading of the main supply potential V_{cc} will suffice. With no input signal $+V_{cc}$ will be found on the top heat sinks and when the line voltage is 10% high will read +67 volts. Adjust R414 fully CW as seen from the knob side of the control. Adjust the variac for 10% above nominal voltage. Set the time delay and low frequency protection switches to off. Slowly rotate R414 CCW until the power relay drops open. This is the correct setting for R414.

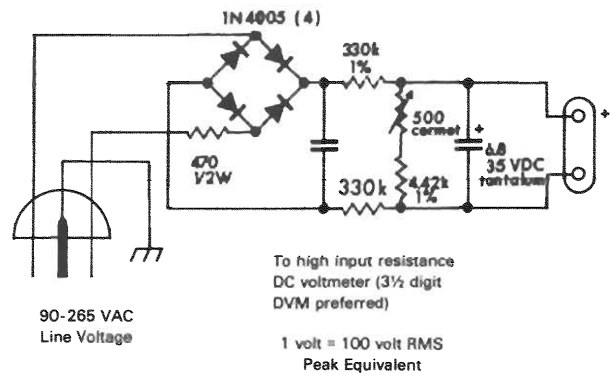

Fig. 3-11. Peak Sensing Line Voltage Monitor

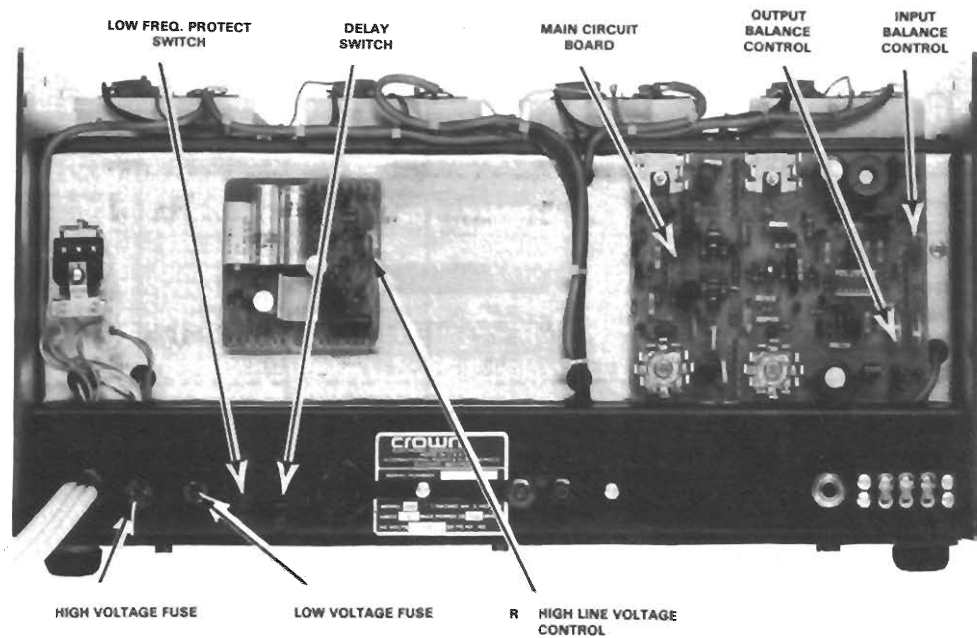

Fig. 3-12. M-600 Rear View (Cover Removed)

CROWN
M-600

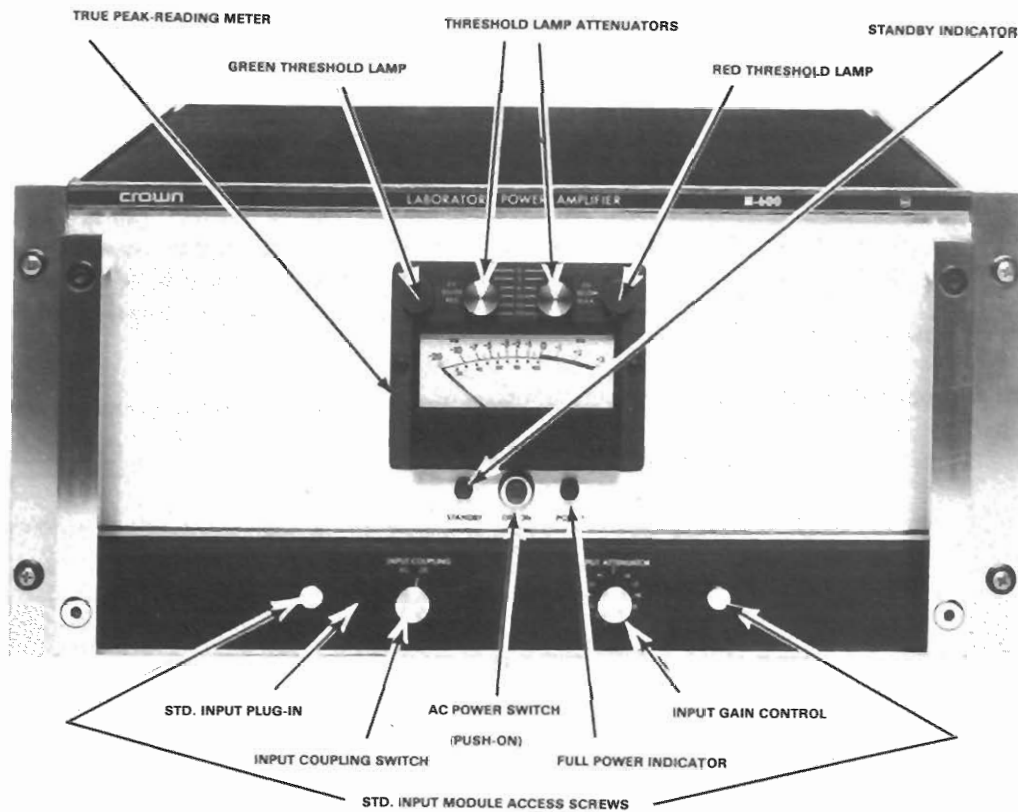

Fig. 3-13. M-600 Front Panel

3.6. Controls and Adjustments

The standard input plug-in contains an input level attenuator and an AC-DC input coupling switch. On an M-2000 only the input controls on the master unit (M-600) are used.

The peak level indicator lights have threshold control switches which are mounted above the meter. The "dB below max." switch controls the threshold of the red indicator lamp where "max." is approximately 110V peak output. The "dB below red" switch controls the threshold of the green indicator. This results in the "dB below red" switch defining the operating range (green) while the "dB below max." defines the overdrive level (red) for a system.

The AC power switch, mounted directly below the meter and between the standby and power indicators is of

mechanically indicating push-push type. If the AC power switch is engaged the power indicator should be on unless power is not connected or a fuse is blown.

On the rear of the unit are mounted two slide switches labeled DELAY and L.F.PROT. Engaging the DELAY switch (up position) inserts a 4-5 second time delay in the state transition from standby to high power supplies on. Engaging the L.F.PROT. switch (up position) causes the unit to go to the standby mode if low frequency (subsonic) outputs of more than 10 volts occur. The 4-5 second time delay is automatically engaged by this switch.

The DC balance controls located behind the back panel seldom, if ever, need adjustment. ONLY in the most critical applications will they need adjustment (not sound reinforcement). To adjust the DC balance controls, use the following procedures (see main circuit board layout in Sec. 4):

1. Make sure amp has been allowed at least 15 minutes of warm-up.

2. Set input level control fully CCW.

3. Remove input signal from corresponding input.

4. Place sensitive DC voltmeter across output.

5. Adjust output balance control using small flat-bladed screwdriver for zero reading on voltmeter.

6. Turn level control fully CW and set AC-DC switch to AC.

7. Adjust input balance control using small flat-bladed screwdriver for zero reading on voltmeter.

The DC balance controls are now adjusted.

Other internal adjustments are discussed in Sections 7 and 3.5.

3.7. The Protection Mechanisms

The M-600 is protected against all the common hazards which plague highpower amplifiers, including shorted, open, and mismatched loads; overloaded power supplies; excessive temperature; chain destruction phenomena; input overload damage; high frequency overload blowups; and high line voltage.

Protection against shorted and low impedance loads is provided by the Signal Programmed Automatic Current Executor (SPACE control). It functions as an automatic current limiter at audio frequencies whose value of current limiting threshold is dependent on the history of the output signal. Output current causes the threshold to decrease while output voltage causes the threshold to increase. The no signal threshold is high enough to allow tone bursting (even into 4 ohms) without premature limiting.

Since the limiter has no instantaneous response to output

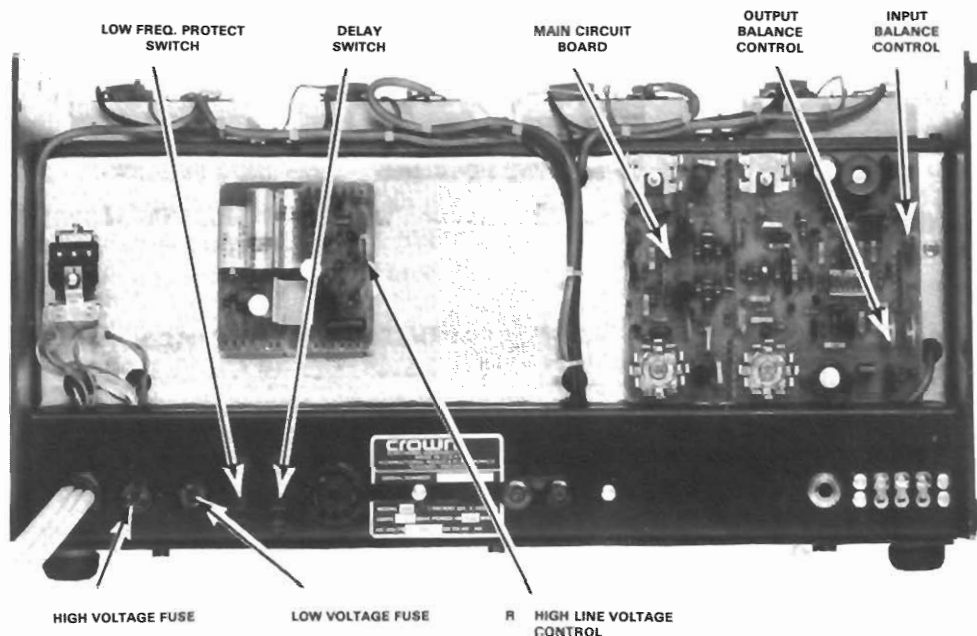

Fig. 3-14. M-600 Rear View (Cover Removed)



CROWN
M-600

voltage, flyback transients do not appear in the output when limiting occurs on inductive loads. Flyback transients are a necessary response of a VI limiter when limiting drive to an inductive load. The actual response of the flyback pulse is that the amplifier yields to the load resulting in a pulse emanating from the load which returns the inductive energy of the load to the opposite polarity power supply of the amplifier as that supply that produced the excessive output. The audible effect of flyback pulses is to produce a rasping, popping sort of sound which is not pleasing.

A current limiter will not yield to the load but will sustain the constant current demands of the inductive load without flyback.

At subsonic frequencies, the SPACE control behaves as a VI limiter and provides the increased protection needed at DC to prevent destruction due to heat buildup in the half of the output stage that is being driven.

Fuses inherently protect the power supplies against overload. The AC line for the main supply 120VAC is fused with a 20A 250V type AB fuse (on 240, 220VAC, 10A type AB 250V).

The low power supply and cooling fan are fused with a 1/2A type AGC fuse on 120 VAC and a 1/4A type AGC fuse on 220 or 240 VAC.

The use of any other fuse sizes will invalidate the warranty.

NEVER CHANGE FUSES WITH POWER APPLIED!

On two of the heat sinks are mounted thermal switches which control the fan speed. Should heat sink temperature rise above 60°C the fan will go into high speed to remove the excess heat. When the heat is removed the fan will resume low speed operation.

On another pair of heat sinks are mounted semiconductor heat sensors (maxies) which at 75°C will place the unit in the standby mode of operation. The fan continues to operate in the standby mode which should quickly remove the excess heat. Such a condition would normally not occur unless a high ambient temperature and high dissipation condition were simultaneously occurring.

All of the amplifier's voltage-amplifier circuitry is designed to be inherently current-limited. Thereby, if any of the devices should fail, (which is extremely unlikely), no damage will occur to the rest of the stages.

The input stage is protected against overdrive damage by a series limiting resistor should the input signal level ever become very excessive.

The amplifier features a controlled slewing-rate which, coupled with the SPACE controller, protects the amplifier from blowups when fed large RF input signals.

3.8. Operating Precautions

The following are a number of operating precautions given as an aid to understanding proper and improper amplifier usage:

1. Use care in making connections, selecting signal sources, and controlling the output level. The load you save may be your own. CROWN is not liable for any damage done to loads due to careless amplifier usage or deliberate overpowering. For pointers on load protection see Section 3.9.

2. Never parallel the output with any other amplifier's output. Such connection does not result in increased power output. Damage incurred by such operation is not covered by the warranty.

3. Never drive a transformer-coupled device or any other device which appears as a low frequency short (less than 3 ohm) without a series isolating capacitor. Such operation may damage the device and/or needlessly waste output power.

Such operation may damage the device and/or needlessly waste output power.

4. Do not short the ground lead of an output cable to the input signal ground as oscillations may result from forming such a ground loop.

5. Never remove fuses with power applied.

6. Operate and fuse the amplifier only as set forth in Sec. 3.7.

7. Operate the amplifier from AC mains of not more

than 10% above the selected line voltage and only on 50 or 60Hz AC. Failing to comply with these frequency limits will also invalidate the warranty.

8. Never connect the output to a power supply output, battery, or power main. Damage incurred by such a hookup is not covered by the warranty.

9. Tampering in the circuit by unqualified personnel or the making of unauthorized circuit modification to other than the input plug-in board invalidates the warranty.

3.9. Load Protection Methods

The most common of all load protection schemes is a fuse in series with the load. The fuse may be single, fusing the overall system. Or, in a case such as a multiway speaker system, it may be multiple with one fuse on each speaker.

Fuses help to prevent damage due to prolonged overload, but provide essentially no protection against damage that may be done by large transients and such. To minimize this problem, high-speed instrument fuses such as Littlefuse 361000 series are most appropriate for such applications. For a nomograph showing fuse size vs. loudspeaker ratings refer to Fig. 3-15.

Another form of load protector is shown schematically in Fig. 3-16. Whenever the load is overdriven, a relay switches a lamp in series with the load, smoothly relieving the overload. The lamp then doubles as an overdrive indicator as it glows. If overdrive is unreasonably severe, the lamp will serve as a fuse. By adjusting the relay tension adjustment and the protection level control, this system is useful from 25 to 200 watts for a typical 8 ohm load.

The use of a limiter-compressor circuit as shown in the applications section is a highly effective way of controlling excessive signals with a minimum of waveform distortion. If a precision clipper limiter is preferred the circuit of Fig. 3-17 may be constructed on the input plug-in card.

The use of such a limiter would be to protect loads that are voltage sensitive and may not be acceptably overvoltage for any length of time. This is not the typical case for sound reinforcement systems which should use a limiter-compressor type of gain control.

Should a system encounter offensive turn-on transients the delay mode switch (rear of unit) should be engaged to prevent immediate turn-on of the amplifier power output. A 4-5 second delay of main supply power results.

If large low frequency signals should threaten sensitive loads, the LF Protection switch (rear of unit) should be engaged to prevent sustained output power which may

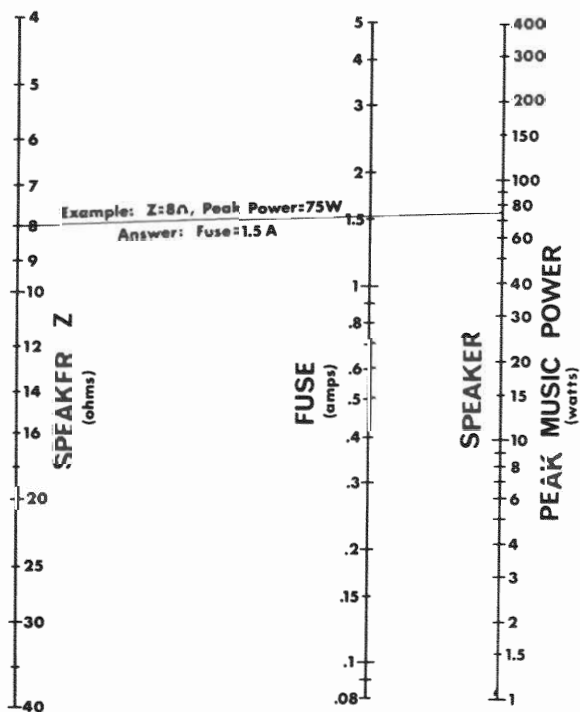

Fig. 3-15. Fuse Selector Nomograph for Loudspeaker Protection

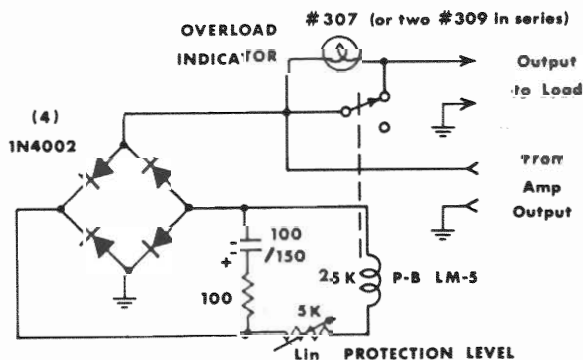

Fig. 3-16. Relay Controlled Protector with Overload Indicator

CROWN
M-600

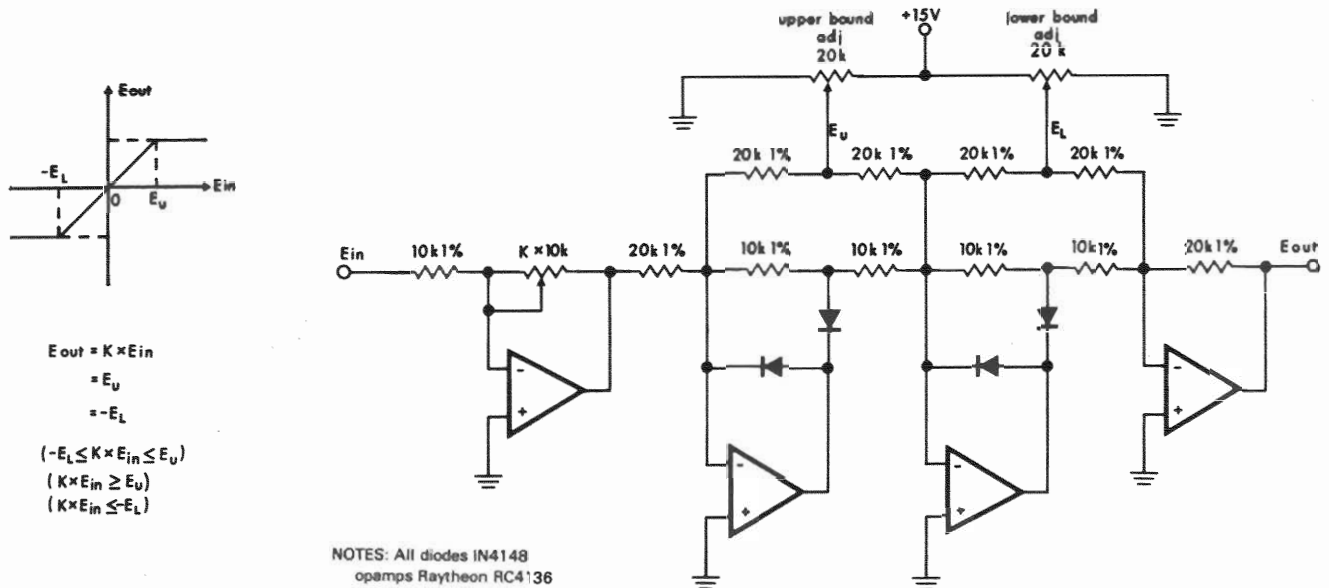

Fig. 3-17. Precision Signal Limiter

damage the load. The delay is automatically engaged with this function. The unit will automatically cycle back on from the standby mode 4-5 seconds after the excessive low frequency output has subsided. Approximately 10 volts of DC output are required to trigger this detector.

If an overload condition of a load or transducer can be electrically or electro-mechanically detected, measures can be taken to:

1. Reduce or limit the amplifier's input drive.
2. Disconnect or decouple the load from the amplifier.
3. Place the amplifier in the standby mode (main power supply not powered).

To externally control the standby mode a real panel interlock connector has been provided. Its operation is the topic of the next section.

3.10. The Interlock Connector

The 11 pin socket on the rear of the unit provides all necessary connections for the interlock system control and is shown in Fig. 3-18. Fig. 3-19 shows the standard M-600 interlock plug supplied with the unit.

Grounding the standby terminal (pin 1) will engage the main AC power relay. As wired with the standard plug, this requires only that transistor Q403 be saturated by the internal control signal. Should a multiplicity of M-600's be used in a system where simultaneous operation is required, such as M2000, the transistors Q403 must be wired in series and the grounds and standby terminals wired in parallel. Fig. 3-20 shows the wiring of an M-2000 interlock cable. A heavy ground is deployed between the output ground posts of the two M-600's composing the M-2000 as all of the output current must pass through this ground. If the grounds of jointly interlocked units are not at the same potential, erratic operation will result.

Opening of the circuit between pin 1 and ground will result in the standby mode for all units jointly interlocked. The current in such a circuit is the number of units (a maximum of 8) X .5ma. Such a current may be easily switched by external sensors or control circuits.

A simple voltage comparator controller is shown in Fig. 3-21. Such a device would be used when voltages could be produced by detectors indicative of system conditions which would result in a voltage comparison to disable or enable the main supplies.

A sum total of 25ma may be drawn from the ± 15 VDC supplies by the input plug-in and remote socket. An additional 25ma may be obtained by removing the front panel meter display.

If large common mode signals exist between the controller and the amplifier an optical coupler may be used to close the interlock circuit. Fig. 3-22 shows an AC powered remote start controller.

Interlock control may be also developed by digital logic. In Fig. 3-23 is shown a TTL IC (Hex Inverter, Open Collector Output) in such a function.

Should crowbaring the output to protect a load be necessary at the time of initiating the standby mode, it may be achieved as indicated in Fig. 3-24.

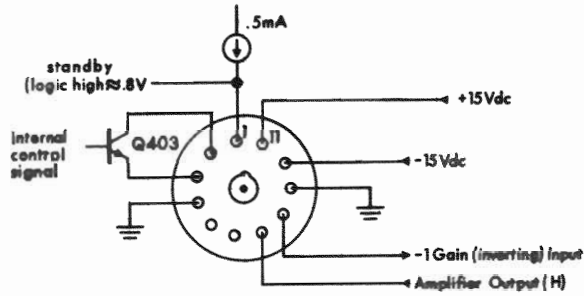

Fig. 3-18. M-600 Interlock Receptacle (Rear of M-600 View)

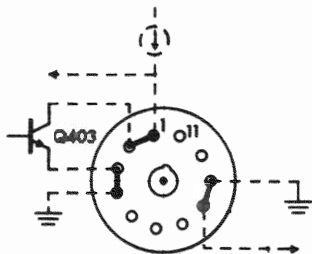

Fig. 3-19. Standard Interlock Plug (Rear of M-600 View)

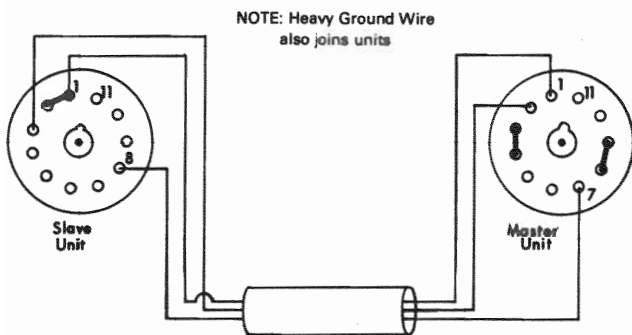

Fig. 3-20. M-2000 Interlock Cable (Rear of M-2000 View)

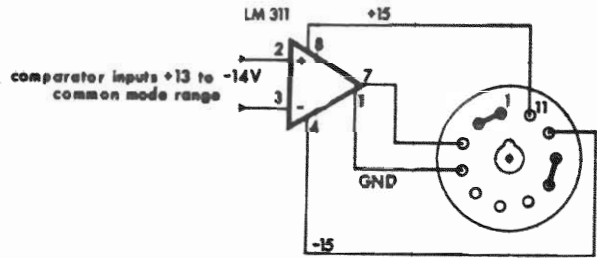

Fig. 3-21. Voltage Comparator Standby Controller (Rear of M-600 View)

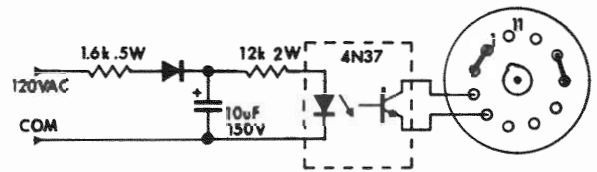

Fig. 3-22. AC Power Remote Start (Rear of M-600 View)

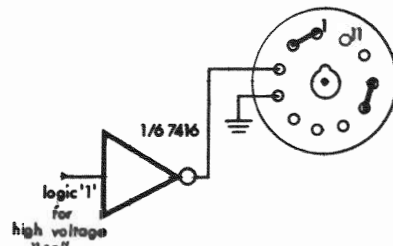
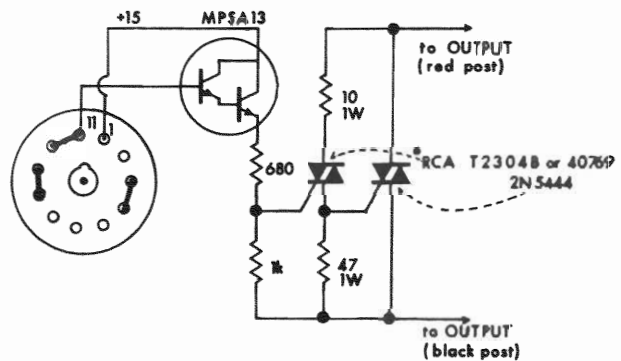

Fig. 3-23. Digital Controller Interface (Rear of M-600 View)



*Selection of this device may be needed for critical $\frac{dv}{dt}$ (off state) spec.

Fig. 3-24. Output Crowbar (Rear View M-600)

3.11. Cleaning

The M-600 has a dust filter on the air intake to the cooling system. Should this filter become clogged the unit will demonstrate impaired cooling and may cycle repeatedly into the standby mode due to an over temp. condition.

This filter is easily removed by pushing in on the plastic web and rotating. Use mild dishwashing detergents and warm water for best cleaning results. Replacement filters may be ordered from the factory.

Dust filters are not 100% efficient and eventually cleaning of the heat sinks will be required especially if the environment is dusty. Such cleaning is best done with compressed air. The amplifier top and bottom covers must first be removed for adequate access. Aim the compressed air directly into the heat sinks. Should the air stream strike the thin aluminum fins obliquely they may be bent and damaged! USE CARE!

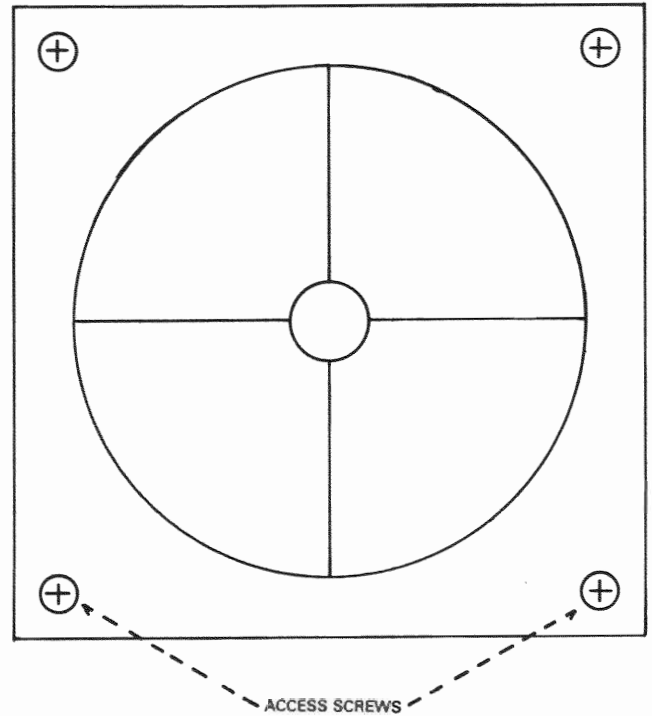

Fig. 3-25. Dust Filter



SECTION 4. THEORY OF OPERATION

4.1. General

The M-600 is a high power direct coupled amplifier with protection circuitry for the power output transistors. It is basically a bridge of four power amplifier elements powered by a floating power supply.

The amplifier is designed to accept many different inputs in the form of plug-in modules for wave shaping and control.

4.2. Principles of Bridge Amplifier

Two quasi-complementary (Class AB+B) amplifiers connected in a bridge make up the power section of the M-600. One side of the bridge is grounded and the other side is powered. The floating power supply powers both sides of the bridge. This allows the load to be driven in reference to ground.

The main quiescent bias current is carried by the driver transistors. The power transistors sense when the drivers are giving a significant current to the load and boost the load current, taking the current load away from the drivers.

The Signal Programmed Automatic Current Executor provides protection for the bridge by acting as an automatic current limiter at audio frequencies, and a VI limiter at subaudio frequencies. The SPACE circuit remembers the history of the output signal and adjust the threshold of current limiting. The no signal threshold of current limiting is high enough to allow full power tone bursting.

4.3. Block Diagram Circuit Theory

Refer to the block diagram, Fig. 4-1. The diagram does not show all circuit connections or feedback loops due to circuit complexity, but there is sufficient data to grasp the function of each circuit.

An input signal is fed to the input amplifier section. The input bias current is offset by the temperature compensated Input Bias Compensator. The input amp amplifies the signal and feeds it to the Signal Translator which divides the signal into two complementary signals. From there the two signals are sent to the last voltage amplifiers which are conventional amplifiers. The signal now feeds into the positive and negative predriver and driver sections which drive the high side power sections. The main bias servo corrects the bias on the driver stage according to the temperature sensed from a positive power section heat sink.

The signal now enters the load from the power sections and is referenced to ground. The feedback signal is taken from the signal terminal of the load and returns to the input amp, signal translator and last voltage amp. The feedback signal also is the input to the Bridge Balance Amp. The amplifier also uses the common point between the positive and negative power supply, (V_{cc} common) as its feedback signal and feeds the BBA buffers which in turn drive the low side power sections. A detailed explanation of the operation of the bridge amp will be found in Section 4.4.

The protection circuit measures the current in the power transistors and stores voltage and current information from the output signal, signals from the last voltage amplifiers, and the bridge balance amp buffers to provide power transistor protection. The Power Control senses high line voltage, high temperature, low frequency output (feature is switched selected) and time delay (also switch selected) and controls the main supply voltage through a relay. Operation is monitored by a red and an amber light on the front panel.

The display obtains its signal from the output of the power amplifier, rectifies the signal and feeds it to the peak comparator which in turn charges a "peak catch-and-hold" capacitor. The capacitor is automatically discharged after a time sufficient for the meter to respond. The signal from the capacitor goes through the meter buffer and to the meter.

The signal from the meter buffer also goes to the threshold warning light circuits. The red and green threshold lights and controls are located on the front panel.

4.4. Detailed Circuit Theory

Refer to the schematic, in Section 4. An input signal is applied to either J1, the standard input, or J2, the special input. The signal is then fed to the plug-in assembly or module.

The following description is for the standard plug-in module; for special modules, refer to the accessories section.

The signal enters the module through P9-19 for the standard input. The special input is not connected on the board, but enters the module through P9-1 and P9-3. To use the special input it is necessary to jumper the appropriate circuit paths on the board. The signal from P9-19 connects to SW500 and C500. Switch SW500 switches the DC blocking capacitor C500 in or out of the input circuit. The signal proceeds to R500 which is the input attenuator. The signal now goes to P9-22 and is routed to P1-4. From this point the signal enters IC-100A, through input protection resistor R105. D100 and D101 form a differential voltage limiting circuit to protect the IC. C105 attenuates RF inputs and controls the apparent input impedance. Input bias current is supplied through resistor R101 and adjusted by R100. R100 receives its voltage from the +15 volt supply and dropping resistor R175.

Q100, R102, R103, R104 and C100 further control the input by forming a temperature sensitive input bias compensator.

Feedback from the power section to the input is accomplished through voltage divider R113 and R112.

Q101 parallels the output of IC100A in order to improve the output response characteristic of the IC. Also, C101, C102 and C103 provide frequency compensation for the IC. The input offset voltage is compensated by R114 and R115.

The signal now appears at the bases of Q104 and Q105, through R110 and R111. Q104 and Q105 translate the signal to the last voltage amplifiers which require complementary signal components to drive the positive and negative power quadrants of the high side of the output bridge.

Following the signal through the positive side, Q104's collector direct couples to Q103, the last voltage amplifier. Q102 limits the collector current of Q103. C135 applies a feedback signal to the base of Q103. C127, C130, and C134 provide slew rate limiting.

Q114 and temperature sensing Q300 (which is mounted on a positive quadrant [high side] heat sink) control the bias for positive and negative predrivers, Q115 and Q117. Q116 is a speed-up device and discharges the base of the positive driver, Q301. As the current through Q301 increases, the voltage across R301 increases and turns on Q302 through Q309. These transistors then carry the heavy current until the voltage on R301 drops and turns them off. This action allows the drivers to carry the main bias current which reduces the bias circuit complexity normally found in high power amps. The negative side of the amp works in the same manner as positive side.

IC100B forms the bridge balance amp. It is basically a comparator using the point between the two high voltage power supplies (V_{cc} common) as its feedback signal. A reference voltage is applied to IC100B through R120 and R124 and is compared with the half voltage across the bridge from R127 and R125. R117 and R119 form the static balancing circuit and R122 tweaks the dynamic balance of the bridge through the voltage dividers using R124, R125 and R121, R123.

The output of IC100B is fed to Q109 and Q110 which buffer and translate the signal to the positive and negative quadrants of the low side predrivers. From here the operation is the same as described previously.

The bridge is protected from inductively induced transients by flyback diodes D300, D301, D302 and D303. C3 and R3 provide high frequency loading for the output. The protection circuitry controls the drive on the bases of Q115 and Q117 which drive the output modules. The output voltage is applied to the emitters of Q108 and Q113 and to C124 and C125. These components along with their associated components form the main output transistor protection circuit. C124 and C125 store a potential related to the history of I_c and V_{ce} . A history of I_c discharges the capacitors so as to reduce the limiting thresholds while a history of diminishing V_{ce} 's will charge the capacitors to increase the limiting thresholds. D105 through D108 are overcharge limiters. Q113 is the positive limiter and gets its I_c information from current sensing resistor R302. Q108 is the negative limiter and obtains its control from R321.

At low frequencies or DC the limiters perform in a foldback manner, i.e. allow increasing output voltage (when the product of output voltage and current is positive). Such a limiter fits a set of straight line approximations to the transistor power dissipation (V vs I) hyperbolas and is generally known as a $V - I$ limiter. When the output voltage polarity is opposite the current polarity (quadrants 2 and 4 of the $V - I$ output graph as shown in Fig. 2-13) the limiters voltage sensitivity is a function of R143 and R141. In quadrants 1 and 3 the network of R140 and R142 is also conducting through D108 or D107 which give increased slope to the limiting line and additional output power without exceeding the output transistor dissipation ratings.



At audio frequencies, C124 and C125 filter all voltage information to Q113 and Q108 such that the instantaneous response is that of a current limiter. R159, C126, and R137, C114 provide positive and negative limiter stabilization respectively. Q111, Q112 and their associated circuitry duplicate the protection circuits previously described, but are referenced to ground and protect the low side of the bridge should it require additional protection.

POWER CONTROL

The power supply is conventional, except the high voltage is not referenced to ground. The low voltage supply is a fixed ± 15 volt regulated, ± 24 V unregulated and $+23$ volts unregulated. IC400 is a fixed ± 15 V dual tracking regulator, thermal and short circuit protected internally and protected from reverse polarity output shorts by D405 and D406.

The power control circuit controls the high voltage relay K1. Q405 drives the relay coil and D407 protects Q405 from flyback transients when the coil de-energizes. Q404 is a phase inverter to control the base of Q405. Q404 receives its control from Q403 through J3 which must be jumpered as shown on the schematic for solo operation. J3 allows up to eight units to be interconnected. (See Section 3.10.)

Q403 is controlled by FET Q402 which forms a time delay controlled by SW2. Q401 is the key control transistor. It is controlled by (1). low frequency protection driver Q400 or signals through R410 (2). R310 and R333 which are mounted on the power heat sinks and sense the temperature of the power transistors and (3). D409 and R414 which sense an increase in line voltage through the -24 V supply.

R414 is adjusted to trip the high voltage relay at $+10\%$ of rated line voltage. This happens by causing the point between the emitter of Q401 and R411 to go negative which biases on Q401. Likewise, either R310 or R333 can cause this point to go negative when the heat sink temperature exceeds 75°C .

The low frequency protection switch SW3 will also engage the turn on delay circuit and connect V_{cc} common to C405 through R409. A DC voltage component will cause C405 to charge and turn off Q400 which turns on Q401 or turn on Q401 directly which causes the relay K1 to disengage the high voltage and place the unit in standby.

The two speed fan is automatically controlled by the thermal switches SW300 and SW301. When the heat sink temperature exceeds 60°C the thermal switches short R8 causing the fan to run at full speed.

DISPLAY BOARD

The output signal enters IC202B which along with D203 and D204 forms a full wave precision rectified negative input current for IC202A. IC202A compares the input signal with the meter output through R218. Should the output signal be greater than the input signal, D205 conducts. If the converse is true, Q200 will conduct. Q200 charges C201 which is buffered by voltage follower IC201A. IC201A drives R218 and the $200\ \mu\text{A}$ meter. The result is that C201 will store the largest peak value of the input signal. The peak catch-and-hold discharge timing circuit consists of Q202, Q203 and IC201B. Hold time is determined by C202 and R229. When Q200 charges C201 its collector current triggers Q202 and Q203 to fully charge C202. During the intervals when D205 is conducting C202 discharges through R229. When the charge on C202 falls below 0 volts, IC201B turns on Q201 which discharges C201, resetting the hold cycle. D206 prevents the leakage in Q201 from discharging C201.

IC200A and IC200B form comparators to control the red and green threshold lights. R202 through R207 form the red threshold resistor network and R208 through R213 form the green threshold resistor network. The selection of the appropriate resistors sets the reference of each comparator. IC200B drives the triac SCR201 which controls the green lamp and IC200A drives SCR200 which controls the red lamp. D201 turns off the green light when the red light comes on. I202 and I203 are the meter lights.

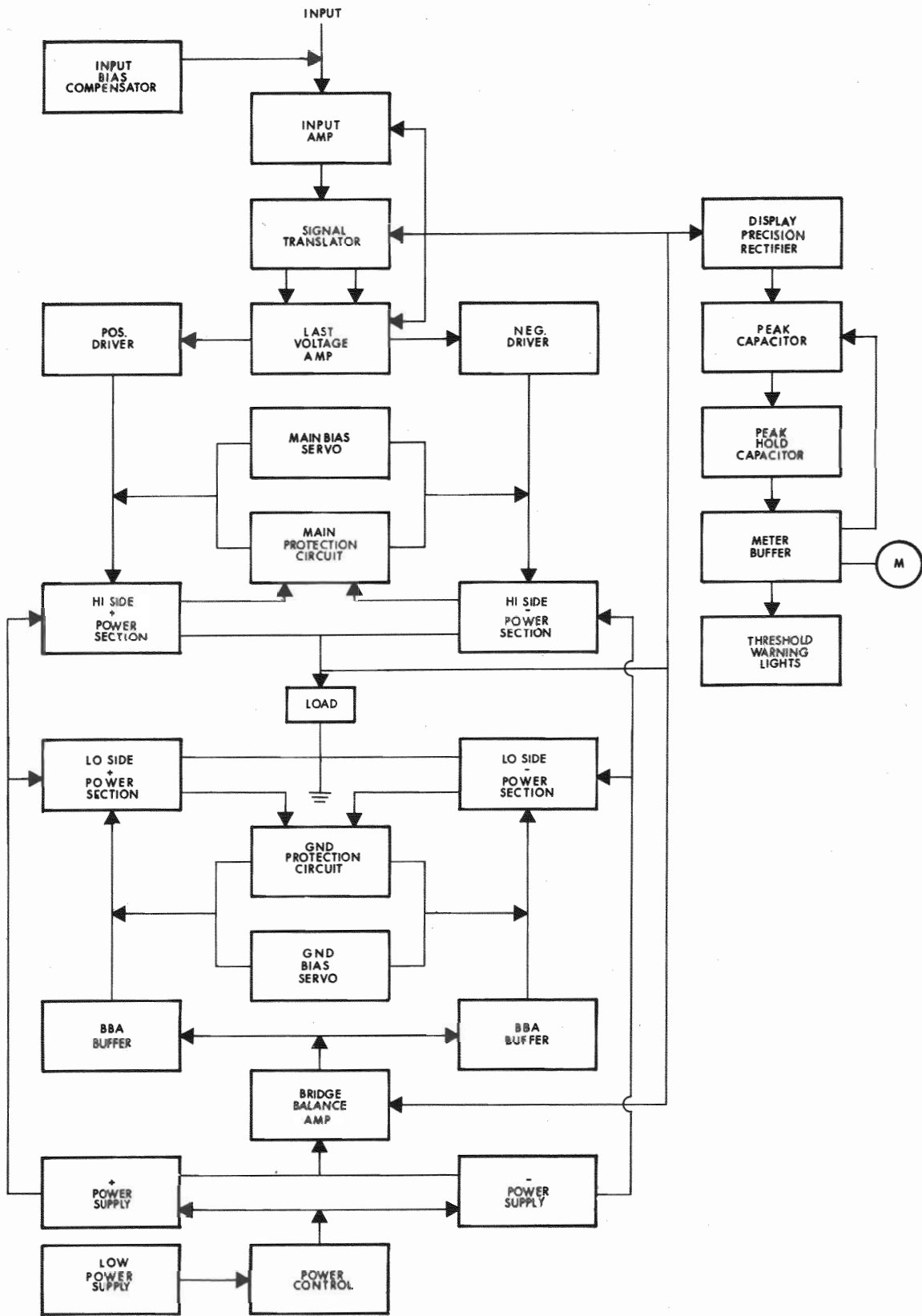
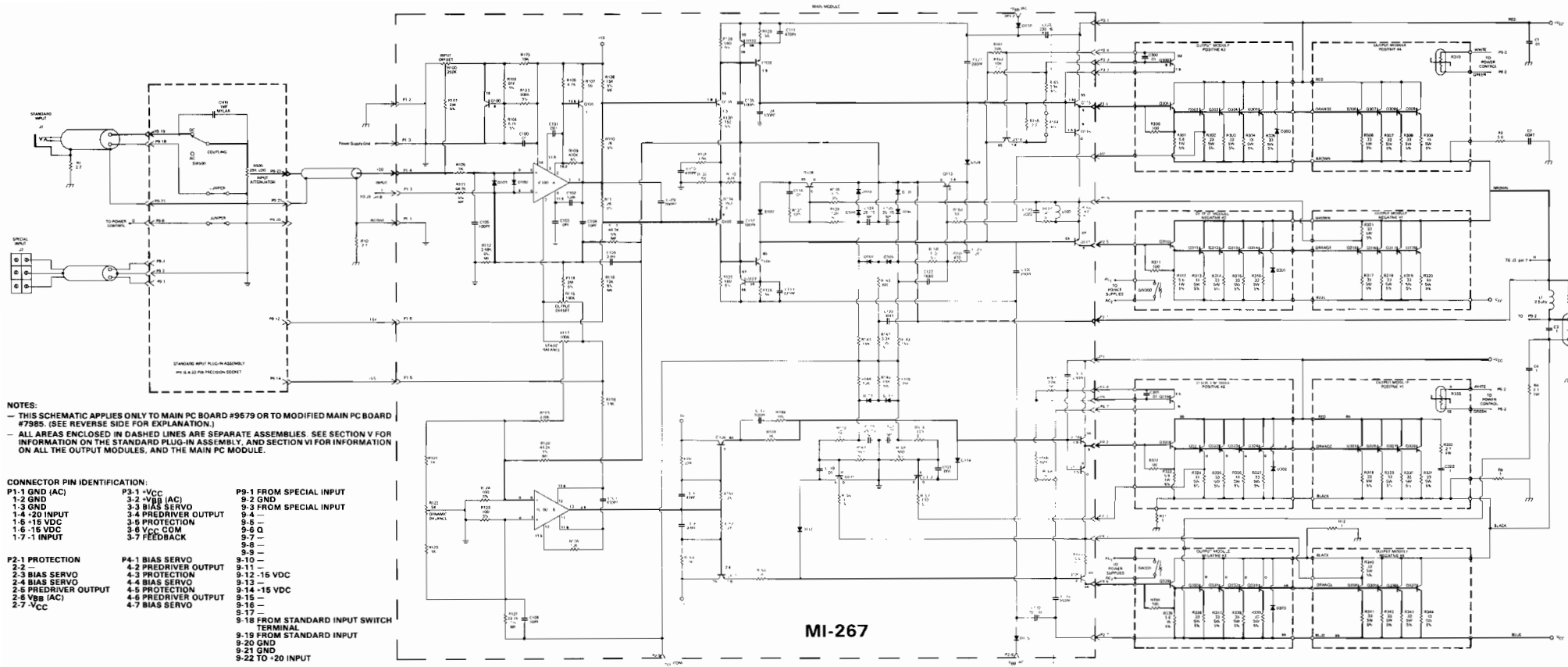

Fig. 4-1. M-600 Block Diagram



NOTES:
 - THIS SCHEMATIC APPLIES ONLY TO MAIN PC BOARD #9679 OR TO MODIFIED MAIN PC BOARD #7985. (SEE REVERSE SIDE FOR EXPLANATION.)
 - ALL AREAS ENCLOSED IN DASHED LINES ARE SEPARATE ASSEMBLIES. SEE SECTION V FOR INFORMATION ON THE STANDARD PLUG-IN ASSEMBLY, AND SECTION VI FOR INFORMATION ON ALL THE OUTPUT MODULES, AND THE MAIN PC MODULE.

CONNECTOR PIN IDENTIFICATION:

P1-1 GND (AC)	P3-1 +VCC	P9-1 GND
1-2 GND	3-2 +VBB (AC)	9-2 GND
1-3 GND	3-3 BIAS SERVO	9-3 FROM SPECIAL INPUT
1-4 +20 INPUT	3-4 PREDRIVER OUTPUT	9-4 -
1-5 -18 VDC	3-5 PROTECTION	9-5 -
1-6 -16 VDC	3-6 Vcc COM	9-6 Ω
1-7 -1 INPUT	3-7 FEEDBACK	9-7 -
		9-8 -
		9-9 -
P2-1 PROTECTION	P4-1 BIAS SERVO	P9-1 FROM SPECIAL INPUT
2-2 -	4-2 PREDRIVER OUTPUT	9-10 -
2-3 BIAS SERVO	4-3 PROTECTION	9-11 -
2-4 BIAS SERVO	4-4 BIAS SERVO	9-12 -15 VDC
2-5 PREDRIVER OUTPUT	4-5 PROTECTION	9-13 -
2-6 VBB (AC)	4-6 BIAS SERVO	9-14 -15 VDC
2-7 +VCC	4-7 BIAS SERVO	9-15 -
		9-16 -
		9-17 -
		9-18 FROM STANDARD INPUT SWITCH TERMINAL
		9-19 FROM STANDARD INPUT
		9-20 GND
		9-21 GND
		9-22 TO +20 INPUT

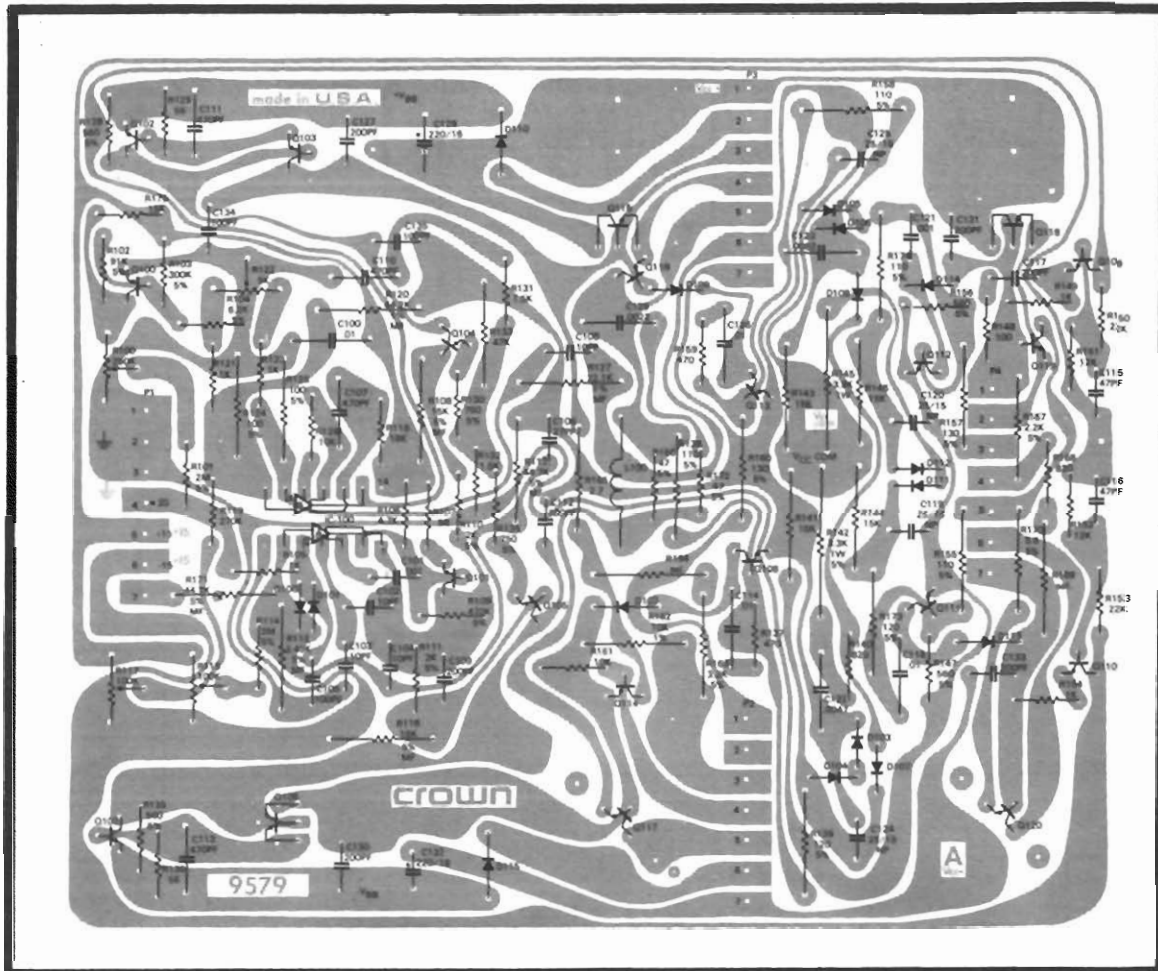

PC MODULE 9579

NOTES:

- PC BOARD #9579 REFERS TO SCHEMATIC MI-267.
- ORIGINAL PC MODULE 7985 ALSO REFERS TO MI-267 IF THE FOLLOWING MODIFICATIONS ARE MADE:
 ADD R147, R156
 CHANGE R174 FROM 100 OHMS TO 110 OHMS
 R155 FROM 130 OHMS TO 110 OHMS
 R173 FROM 110 OHMS TO 120 OHMS
 R138 FROM 120 OHMS TO 110 OHMS

NOTICE THAT PC MODULE 7985 WAS BUILT IN TWO DIFFERENT FORMS. ON THE 7985-1, C117 AND R148 WERE ADDED IN PARALLEL TO R149 ON TOP OF THE BOARD. PC 7985-2 WAS REARRANGED TO INCLUDE BOTH COMPONENTS IN THE LAYOUT. BOTH PC BOARDS ARE ELECTRONICALLY IDENTICAL AND APPLY TO MI-267 IF THE ABOVE MODIFICATIONS ARE MADE.

- THESE CHANGES ARE ILLUSTRATED ABOVE. THE 560 OHM 1/4 WATT RESISTORS ARE ADDED TO THE FOIL SIDE OF THE BOARD.
- MOST 7985 MODULES WERE MODIFIED AT THE FACTORY.

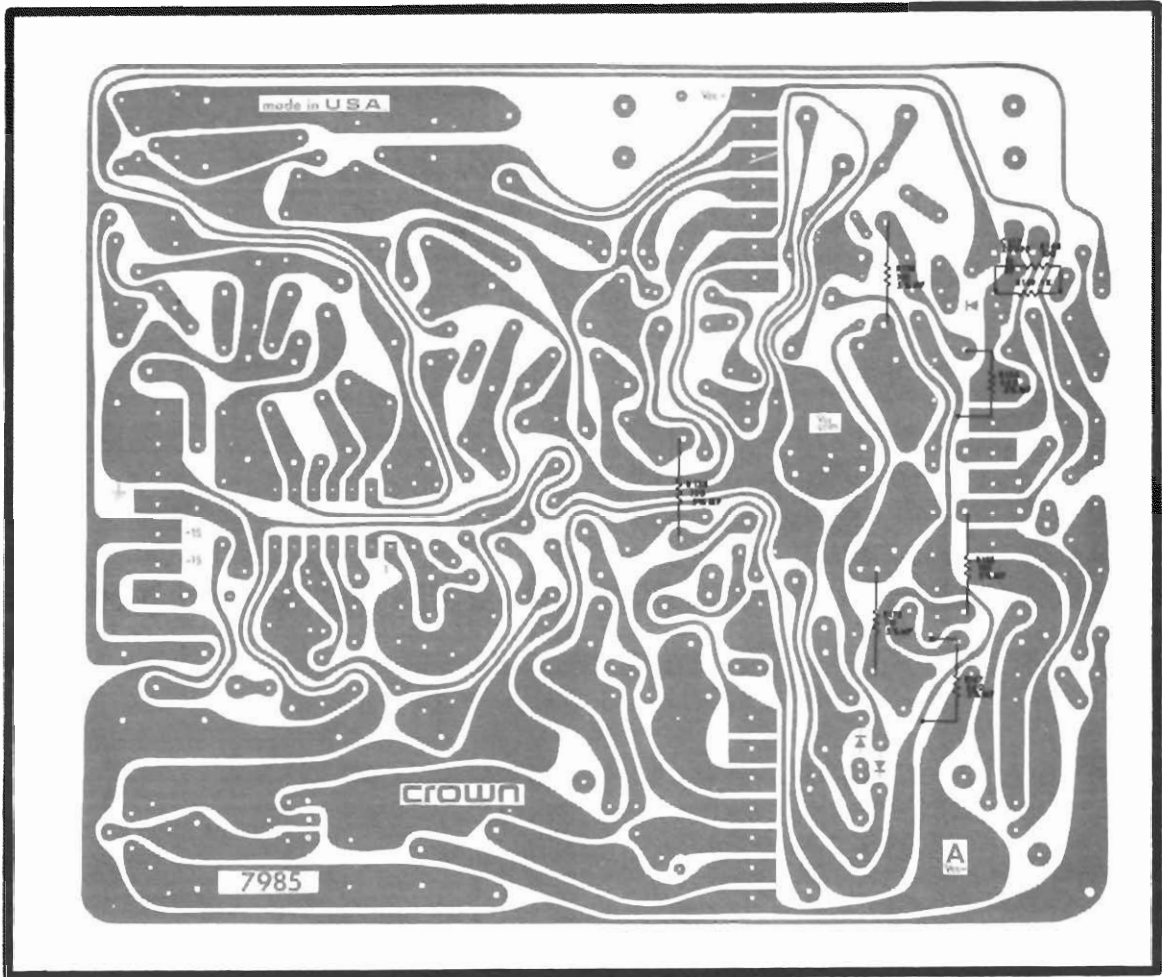

PC MODULE 7985-1

Fig. 4-3 M-600 Main PC Board Layouts, #7985 and #9579

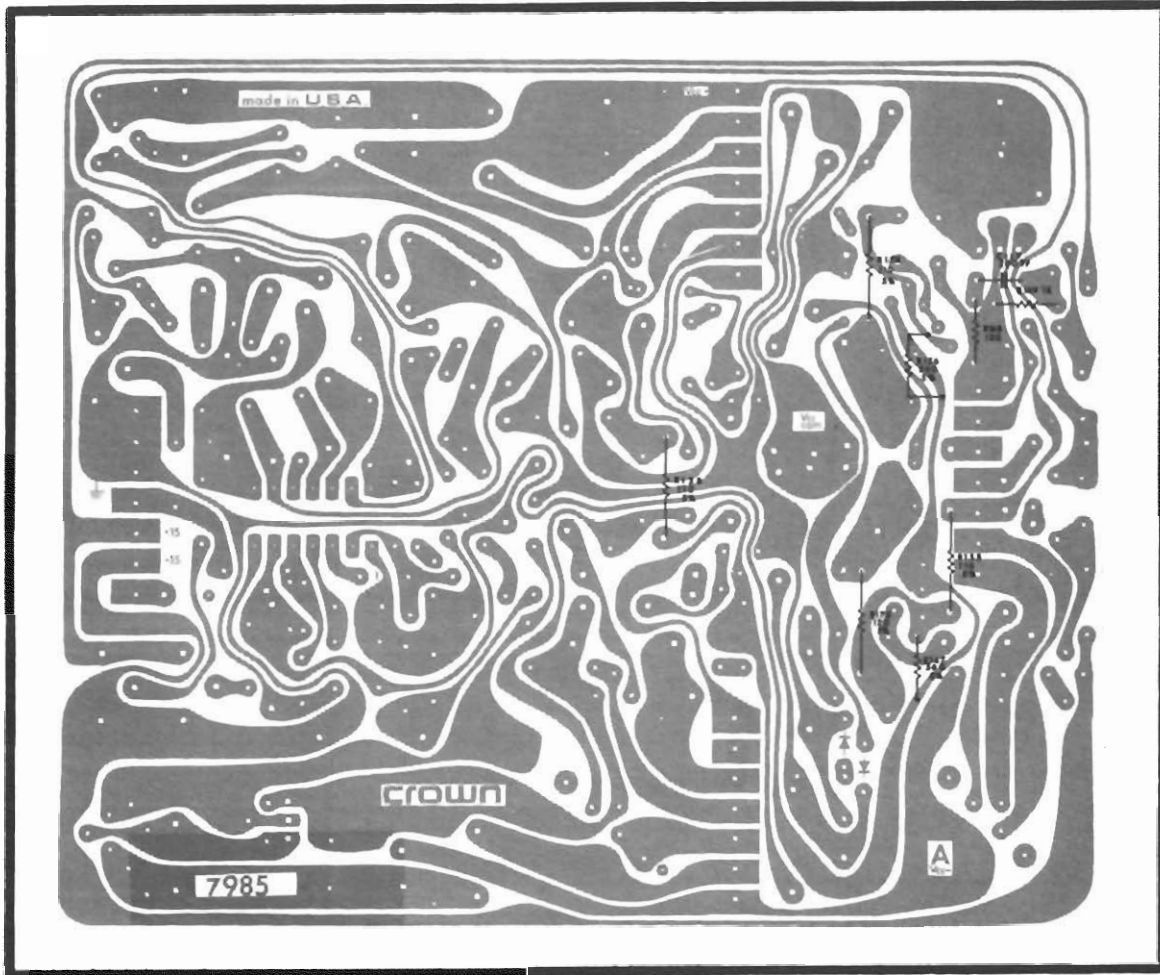

PC MODULE 7985-2

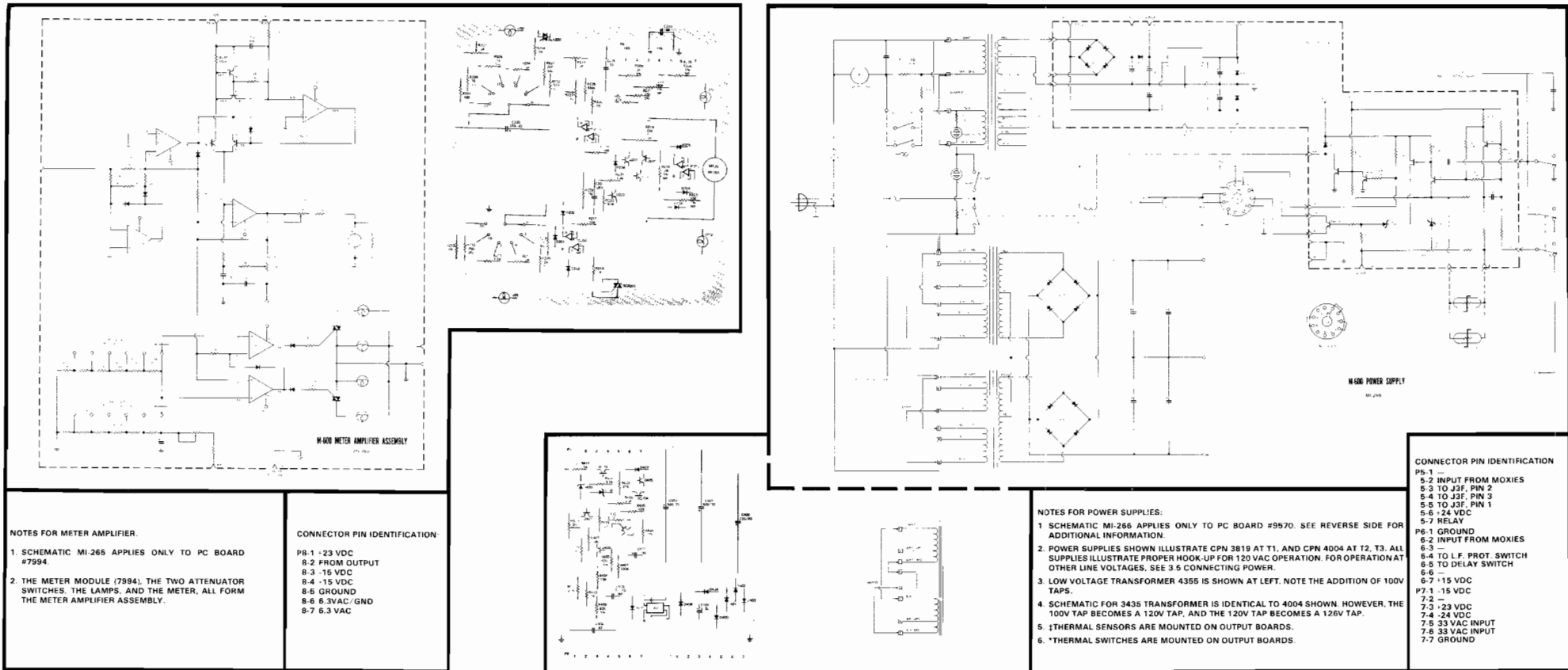
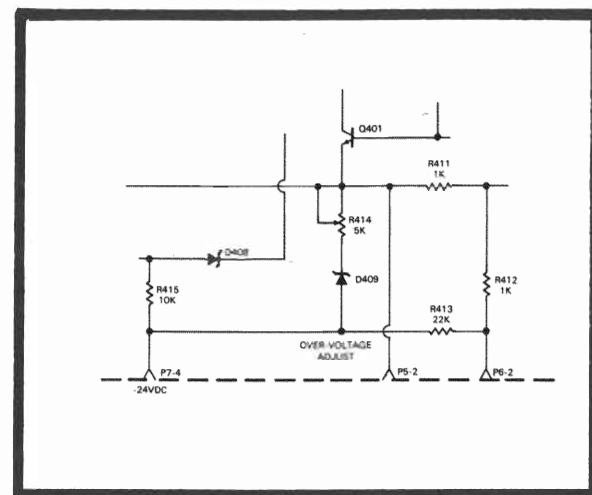
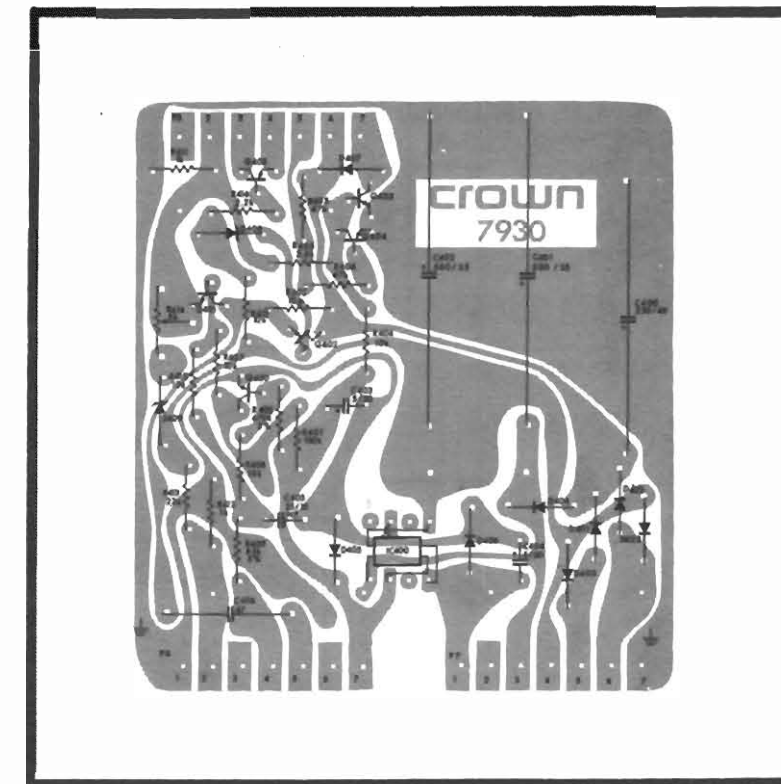

Fig. 4-5 Display Circuit Schematic Diagram

Fig. 4-4. M-600 Power Supply Schematic Diagram



R414 SHOWN IN RHEOSTAT CONFIGURATION



PC MODULE 7930

NOTES:

- EARLY PRODUCTION USED A PC BOARD #7930. THE LAYOUT IS SHOWN ABOVE.
- A PARTIAL SCHEMATIC IS SHOWN ABOVE, ILLUSTRATING THE DIFFERENCES BETWEEN THE TWO CIRCUITS. NOTE IN THE LATEST VERSION THE OVERVOLTAGE ADJUST IS CHANGED FROM A RHEOSTAT TO A POTENTIOMETER CONFIGURATION.
- TO INSURE PROPER OPERATION OF THE ORIGINAL CIRCUIT ZENER D409 MUST BE SELECTED FOR 24 VOLTS OR HIGHER

Fig. 4-6 M-600 Power Supply PC Board Layout

SECTION 5. ACCESSORIES/OPTIONS

5.1. Introduction

This section contains information and schematics for various plug-in modules for the M-600. Some of the modules are available from the CROWN factory pre-assembled while others can be assembled on the universal card supplied with each M-600.

CROWN Engineering will be glad to answer any questions that may arise concerning these and future modules. Also, CROWN Engineering will supply engineering time for special problems that will lead to manufacturing a minimum quantity of special modules. Contact the factory for further assistance.

5.2 Standard Plug-in Assembly

The standard plug-in assembly is shown schematically, Figure 5-2, and pictorially below, Figure 5-1. The PC board provided will provide needed supply and control voltages for many of the input circuits shown in this section. These circuits can be breadboarded right on the universal PC board. A full-size reproduction of the PC foil pattern is provided, Figure 5-3, for your design convenience.

The standard plug-in assembly includes front panel input attenuation and AC-DC switching. This feature is included in most of the suggested input configurations illustrated in this section.

If the additional circuitry breadboarded on the standard plug-in requires adjustment, some form of access to the controls must be provided. A CROWN designed extender card for this purpose (CPN 41471) is available from the Parts Department.

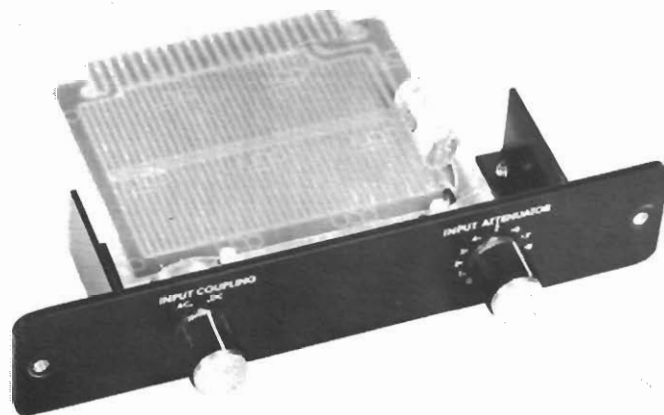

Fig. 5-1 Pictorial, Standard Plug-In Assembly

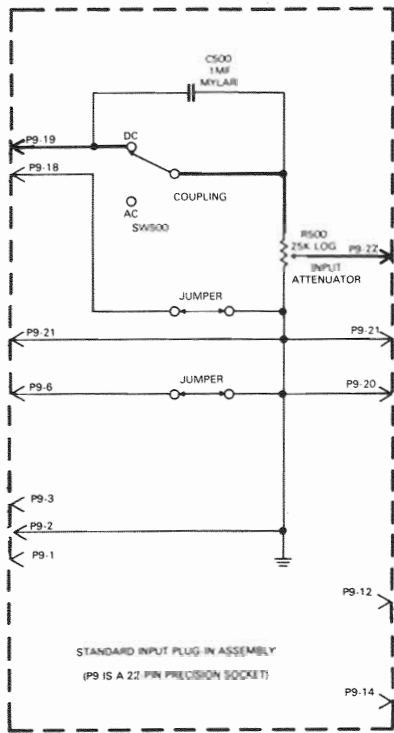

Fig. 5-2 Standard Plug-In Assembly Schematic

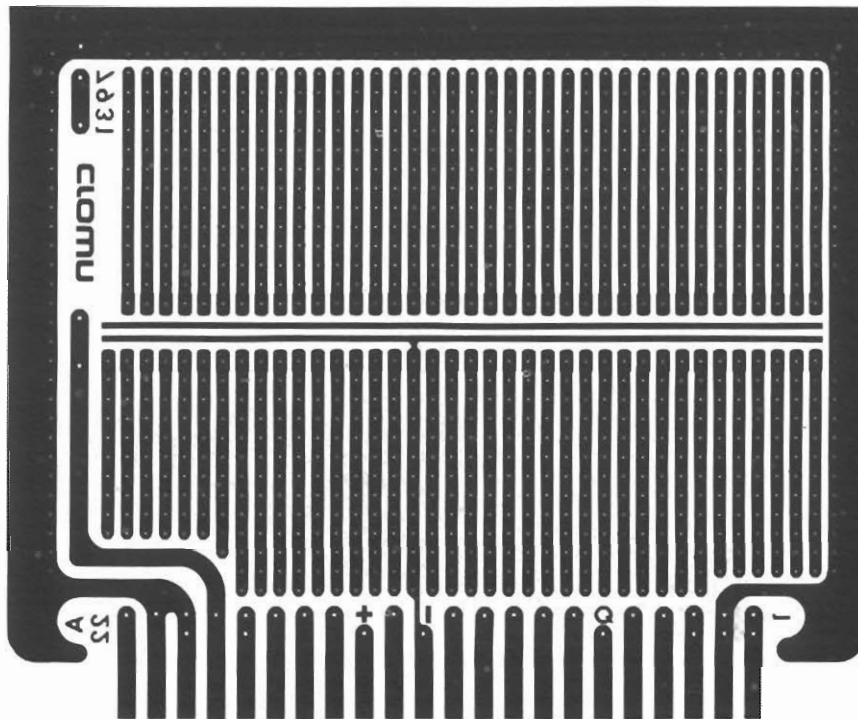
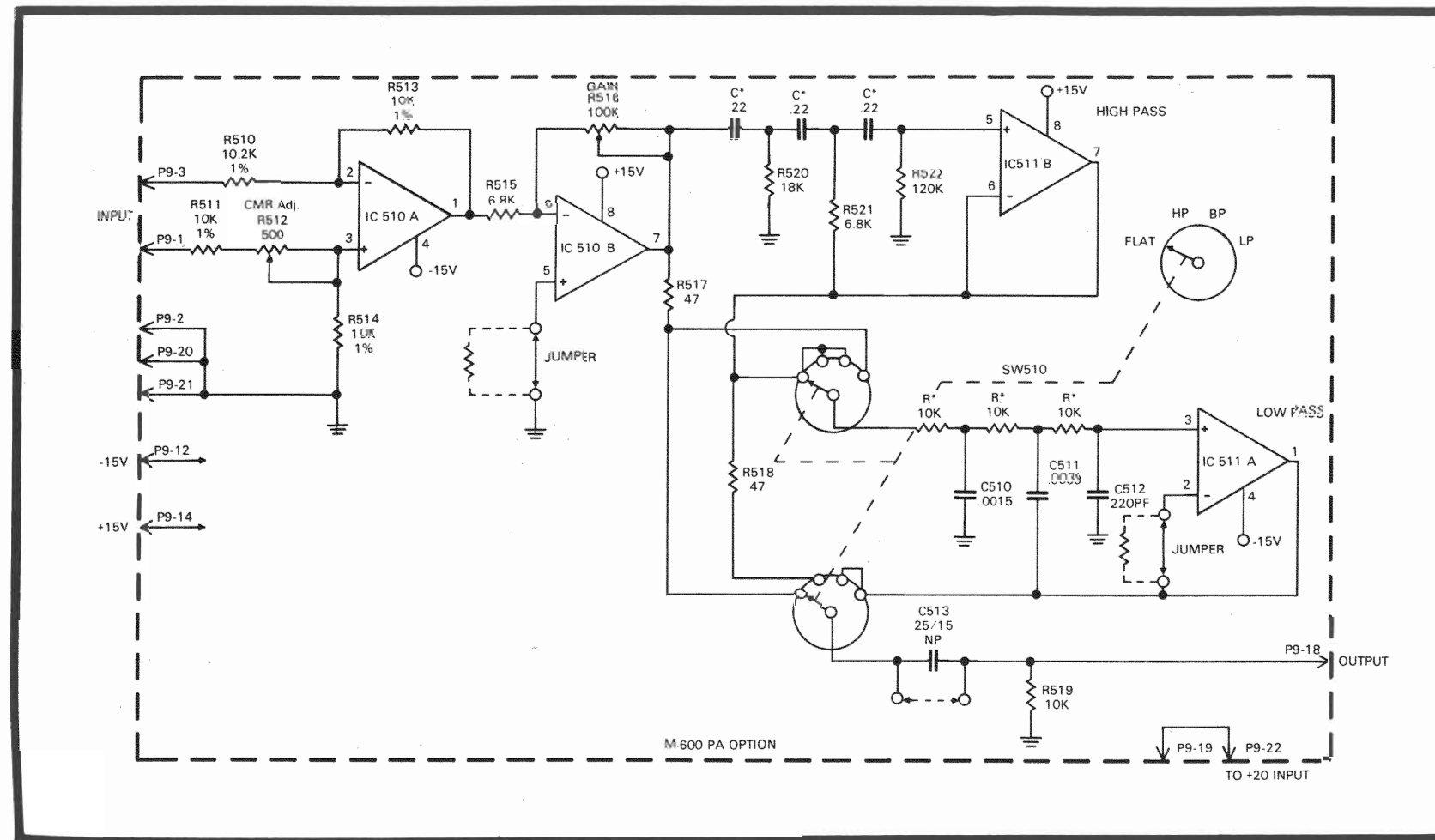

Fig. 5-3 Universal Plug-In PC Board (view from component side)



NOTES:

1. This schematic applies only to PC board #9560.
2. The three changes shown in dotted lines are for industrial applications using DC signals.
3. R* and C* are chosen according to the following general limitations:
 - a) $2K < R^* < 330K$
 - b) $R520 > 2K$
 - c) $R522 < 1M$
4. With valid values of R* and C*, R520, R521, R522, and C510, C511, C512 are chosen according to the following formulas:

$$R520 = \frac{.7184}{2\pi f_h C^*} \qquad C510 = \frac{1.392}{2\pi f_l R^*}$$

$$R521 = \frac{.2820}{2\pi f_h C^*} \qquad C511 = \frac{3.546}{2\pi f_l R^*}$$

$$R522 = \frac{4.941}{2\pi f_h C^*} \qquad C512 = \frac{.2024}{2\pi f_l R^*}$$

when f_h = highpass cutoff

f_l = lowpass cutoff

5. For values of C*, R*, C510, C511, C512, R520, R521, and R522 shown $f_h = 30\text{Hz}$ and $f_l = 15\text{KHz}$.
6. Inserting a plug into the standard input jack (J1) disconnects the filters.

5.3 PA Option

The PA option plug-in module is designed to optimize the M-600 for public address sound reinforcement service. The plug-in has the following features:

- 600 ohm balanced input
- Front panel gain control
- Filter networks (3 pole Butterworth) providing the following switch selectable functions:

High pass filter (30Hz)

Band pass filter (30Hz-15KHz)

Low pass filter (15½Hz)

Flat

- Directions are provided for changing the filter frequencies.

Circuit Description

A balanced input is provided by one-half of a 4558 operational amplifier providing unity gain. R512 provides common mode rejection adjustment for this stage. The other half of the 4558 provides driving power for the 3 pole Butterworth filters. R516 controls the gain of this stage and is located on the front panel of the module. A gain a 4558 makes up the two filter sections whose operation is switch-selected from the module's front panel.

Selecting Frequency Determining Components

After determining the desired cut-off frequencies, use the instructions and formulas in the notes to determine correct component values.

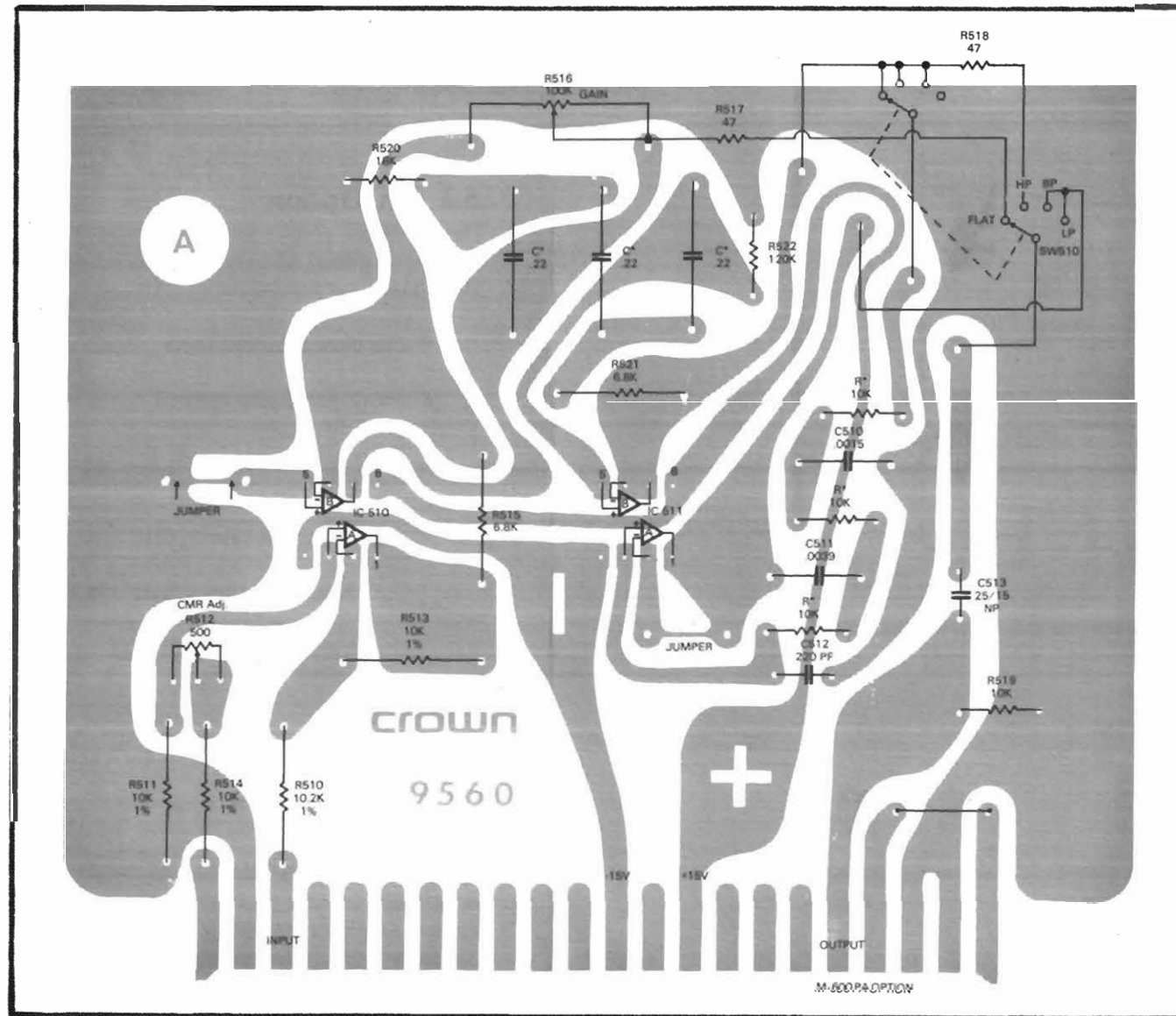

LEGEND:

- ● — = JUMPER WIRE
- □ — = (COMPONENT STANDING ON END)
- X — = CUT TRACE
- VIEW FROM FOIL SIDE OF PC BOARD

Reference Designation

Description

Crown Part No.

Other Information

Miscellaneous

- M-600 access door 9529
- Front end bracket 9530
- Circuit board 9560
- #8 x .375 hex SMT screw 2708
- Control knob 3513

Resistors

- R510 10.2K ohm 1/2 watt 1% MF 2344
- R511, R513, R514 10K ohm 1/2 watt 1% film 2343
- R512 500 ohm helipot trim 3668
- R515, R521 6.8K ohm 1/2 watt 1639
- R516 100K ohm audio pot ZY7194 2341
- R517, R518 47 ohm 1/2 watt 5% CF 2528
- R519, R*, R* 10K ohm 1/4 watt 5% CF 2631
- R520 1.8K ohm 1/4 watt 2633
- R522 1.20K ohm 1/2 watt MF 3856

Capacitors

- C510 .0015 MF 200V filmatic 3089
- C511 .0039 MF pacer 1693
- C512 200 P.F. mica 3411
- C513 25 M/F 15V NP vertical 3186
- C*, C*, C* 0.22 MF 100V filmatic 3218

Integrated Circuits

- IC510, IC511 RC4558 dual op amp 3919

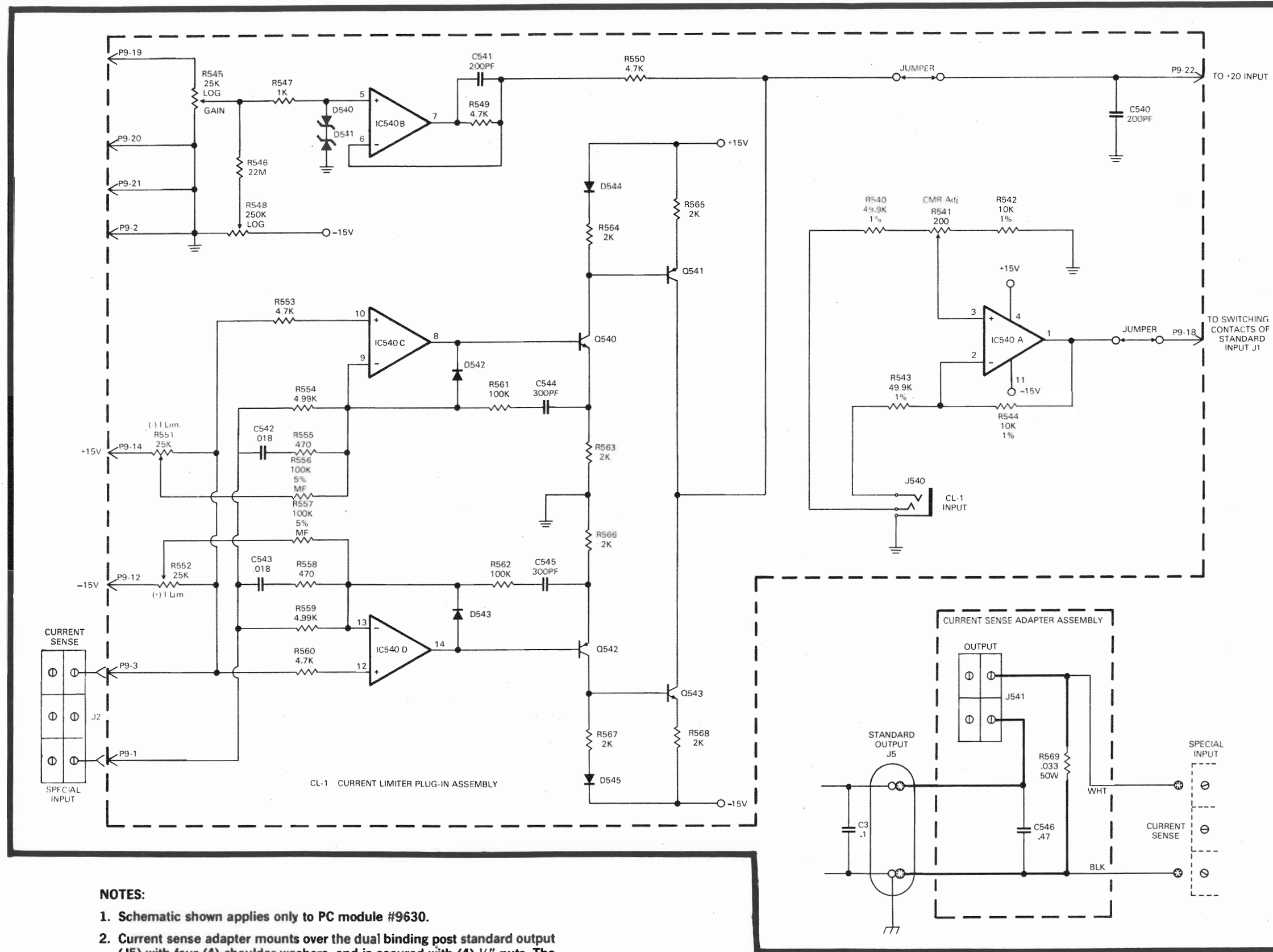

5.4 CL-1, Current Limiter for Motor Control

The CL-1 module is specifically designed for current limiting with a load of 14.4 mH in series with a 2 to 2.5 ohm resistance. Other loads will require compensation. Contact CROWN for further information and assistance if needed.

Circuit Description

The output current is sensed across a .033 ohm 50W resistor in series with the output. The voltage across this resistor is fed to a differential comparator circuit comprised of two sections of an HA-4741 quad op amp using the $\pm 15V$ power supply to set the \pm current limiting points.

Another section of the HA-4741 forms a current limited voltage follower and the fourth section provides for a balanced input.

The current limit adjustment spans from 100 mA to ± 20 A.

NOTES:

1. Schematic shown applies only to PC module #9630.
2. Current sense adapter mounts over the dual binding post standard output (J5) with four (4) shoulder washers, and is secured with (4) 1/4" nuts. The current sense wires are connected to the adjacent special input (J2). The existing plastic screws on J3 must be removed before assembling the adapter over the binding posts.
3. If a plug is inserted into the standard input (J1), the CL-1 input (J540) will be disconnected.

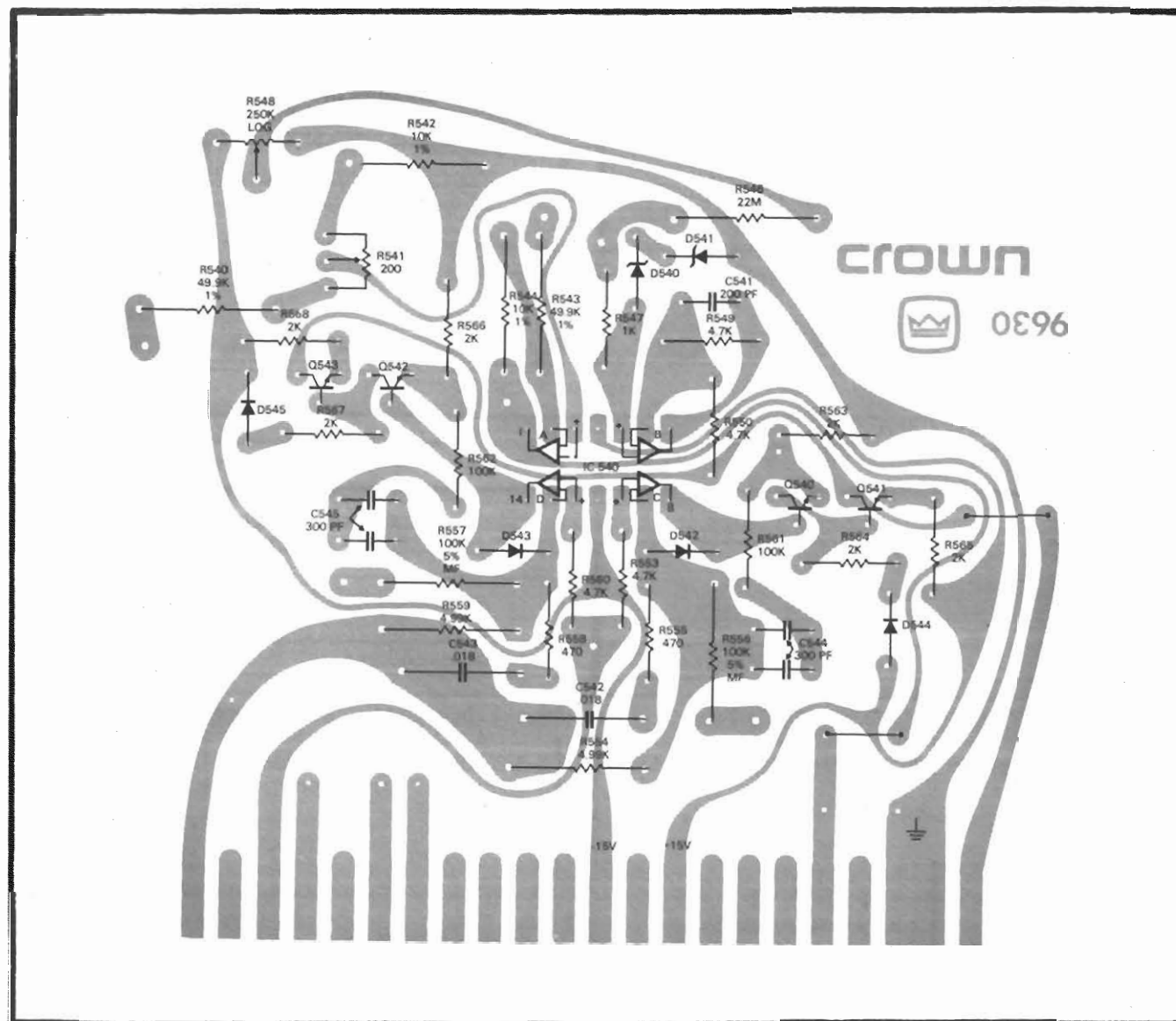

LEGEND:

- ● - = JUMPER WIRE
- □ = COMPONENT STANDING ON END
- X = CUT TRACE
- VIEW FROM FOIL SIDE OF PC BOARD

Reference Designation	Description	Crown Part No.	Other Information
Resistors			
R540, R543	49.9K ohm ½ watt 1% MF	NA	
R541	200 ohm helipot trim	3683	
R542, R544	10K ohm ½ watt 1% MF	2343	
R545	25K ohm LOG pot	3030	Gain
R546	22M ohm ½ watt 10%	3052	
R547	1K ohm ¼ watt 5% CF	2627	
R548	250K ohm vert. wht. pot log	3028	
R549, R550	4.7K ohm ¼ watt 5% CF	3939	
R551, R560			
R551, R552	25K ohm pot	NA	Clarostat PN 73JA 25K ohm 5%
R555, R558	470 ohm ¼ watt 5% CF	2626	
R556, R557	100K ohm ½ watt 5% MF	2324	
R561, R562	100K ohm ¼ watt 5% CF	2883	
R563, R564	2K ohm ¼ watt 5%	3804	
R565, R566, R567, R568			
R554, R559	4.99K ohm ½ watt 1% MF	3686	
Capacitors			
C540, C541	200 PF mica	3411	
C542, C543	.018 MFD paper	2198	
C544, C545	300 PF	3410, 3411 CPN 3410 and 3411 can be used in parallel to form 300 PF.	
Transistors			
Q540, Q543	Sel. 2N3859A NPN	2961	
Q541, Q542	PN 4250A PNP	3786	
Diodes			
D540, D541	1N961B 10 volt zener	3549	
D542, D543, D544, D545	1N4148	3181	
Integrated Circuits			
IC540A, B,C,D	HA-4741 quad op amp	4160	
Miscellaneous			
	CL-1 Front panel		
	CL-1 PC board		
	M-600 Front end bracket	95305	
	.25 Control nut .375L	3040	
	.375 Bright nut	1288 NIC	
	.375 Knurled nut	3495 BLK	
	.375 Int. star lock washer	2188	
	.625 x .375 x .030 BRT washer	2189 NIC	
	Shift rod bearing	3366	
	N112B 3-Cond. Hi D Jax	3507	
	#8 x .375S hex smt screw	2708	
	NSECO 1510-12 shaft lock	3450	

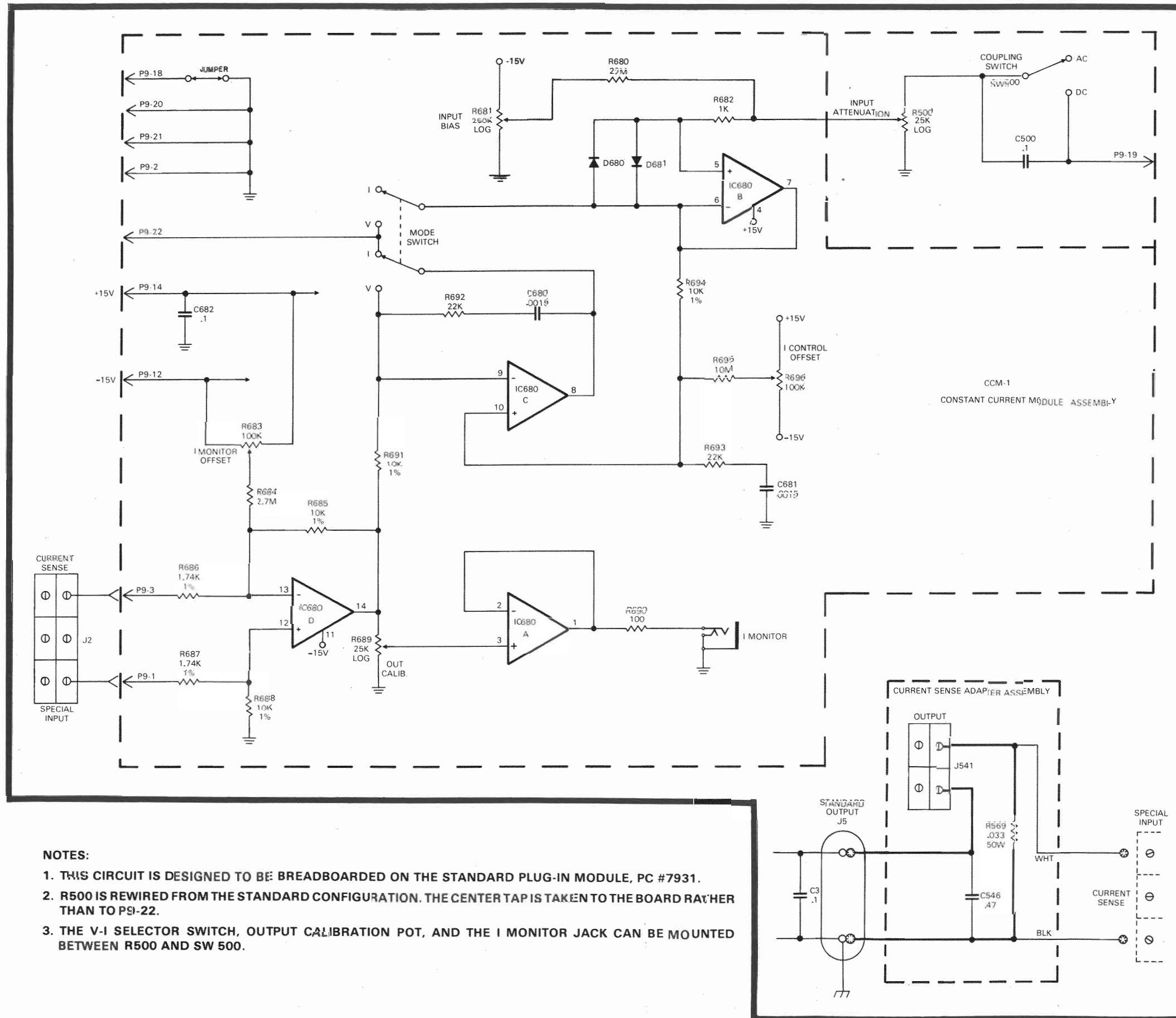

5.5 CCM-1, Constant Current Module

The CCM-1 module provides two switch selectable modes; constant voltage output controlled by input voltage and constant current output controlled by input voltage.

Circuit Description

The CCM-1 is comprised of an HA-4741 quad op amp. Two of the sections are used as current and voltage comparators, a third is used as a current source amplifier and the fourth is used as a buffered output for monitoring purposes. The current sense is provided by a .033 ohm 50W resistor in series with the M-600 output. This particular circuit is designed to control the M-600 for use in driving shake tables.

NOTES:

1. THIS CIRCUIT IS DESIGNED TO BE BREADBOARDED ON THE STANDARD PLUG-IN MODULE, PC #7931.
2. R500 IS REWIRED FROM THE STANDARD CONFIGURATION. THE CENTER TAP IS TAKEN TO THE BOARD RATHER THAN TO P9-22.
3. THE V-I SELECTOR SWITCH, OUTPUT CALIBRATION POT, AND THE I MONITOR JACK CAN BE MOUNTED BETWEEN R500 AND SW 500.

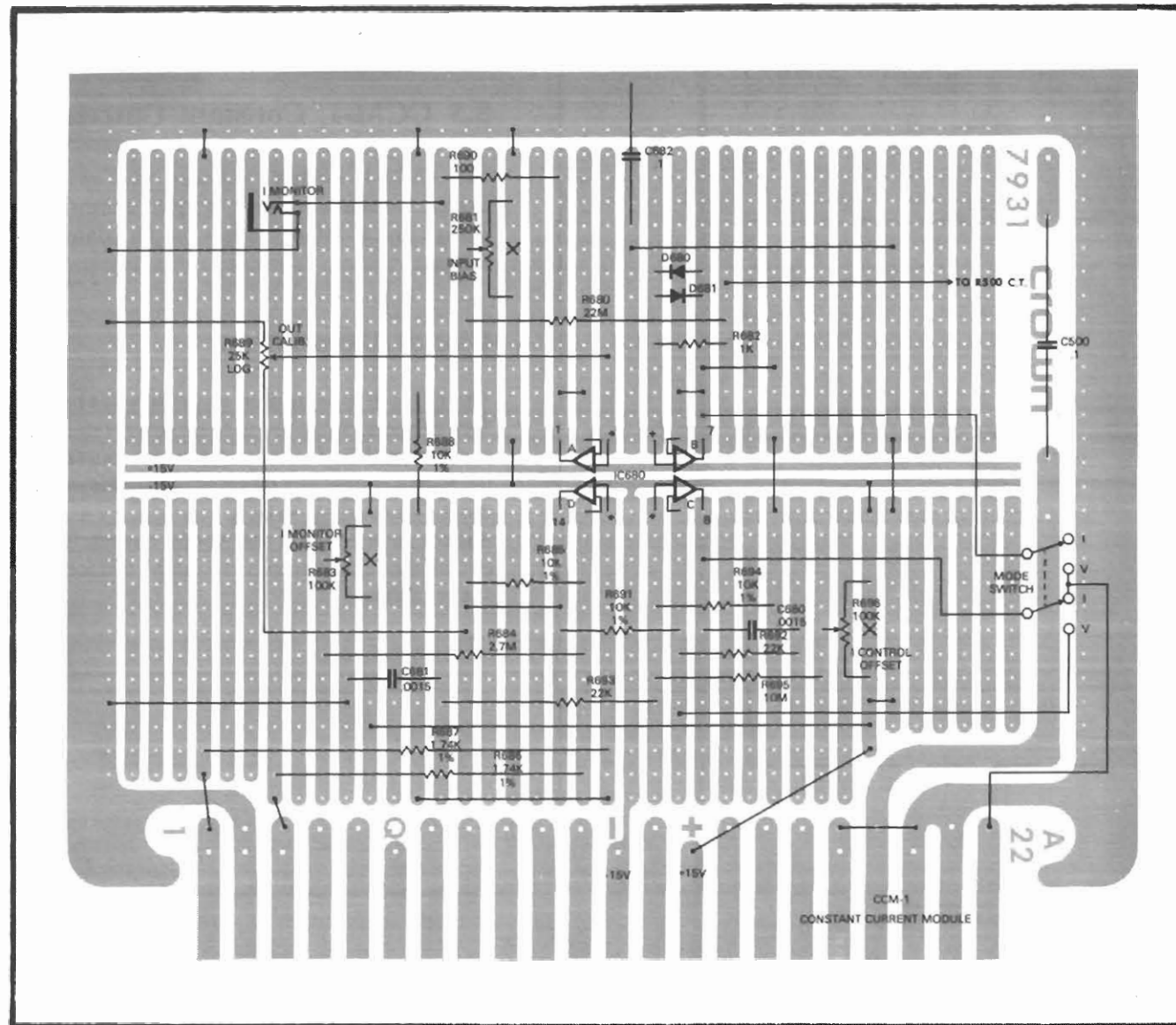

LEGEND:

- ● — = JUMPER WIRE
- □ — = COMPONENT STANDING ON END
- X — = CUT TRACE
- VIEW FROM FOIL SIDE OF PC BOARD

Reference Designation

Description

Crown Part No.

Other Information

Resistors

R680	22M ohm ½ watt 10%	3052	
R681	250K ohm log pot	3028	Input bias
R682	1K ohm ¼ watt 5% CF	2627	
R683, R696	100K ohm pot	1713	I monitor offset — R683 I control offset — R696
R684	2.7M ohm ¼ watt 5% CF	2634	
R685, R688, R691, R694	10K ohm ½ watt 1% MF	2343	
R686, R687	1.74K ohm ½ watt 1% MF	3929	
R689	25K ohm log pot	NA	Out calib.
R690	100 ohm ¼ watt 5% CF	2872	
R692, R693	22K ohm ¼ watt 5% CF	3302	
R695	10M ohm ¼ watt 5% CF	3221	

Capacitors

C680, C681	.0015 MF ceramic disc	2218	
C682	.1 MF 200V filmatic	2938	

Diodes

D680, D681	1N4148	3181	
------------	--------	------	--

Integrated Circuits

IC680A,B, C,D	HA-4741 quad op amp	4160	
---------------	---------------------	------	--



5.6 Current Sense Adapter Assembly

The current sense adapter is used with the CL-1 current limiter module and CCM-1 constant current module. The assembly is installed over the output terminals (J5) at the rear of the M-600.

To install, first remove the four nuts retaining the barrier strip on the adapter. Remove the barrier strip. Remove the red and black plastic nuts from the main output terminals.

Install two fiber shoulder washers over the output terminals. Fit the assembly over the output posts making sure the shoulder washers seat into the holes and properly insulate the output posts. Install the two 1/4" star solder lugs with white wires, then secure with 1/4" hex nuts. Reinstall the barrier block. The white and black wires with the #8 star solder lugs are connected to the special input, J2. The barrier strip becomes the new output connector.

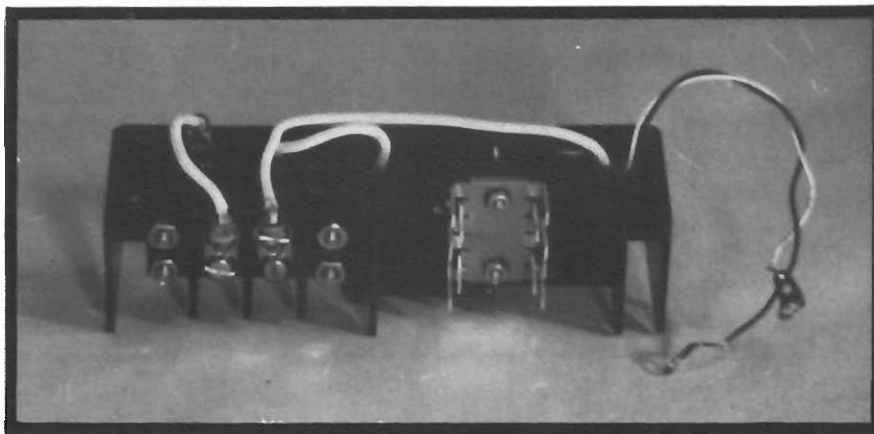

Fig. 5-4 Pictorial, Current Sense Adapter Assembly

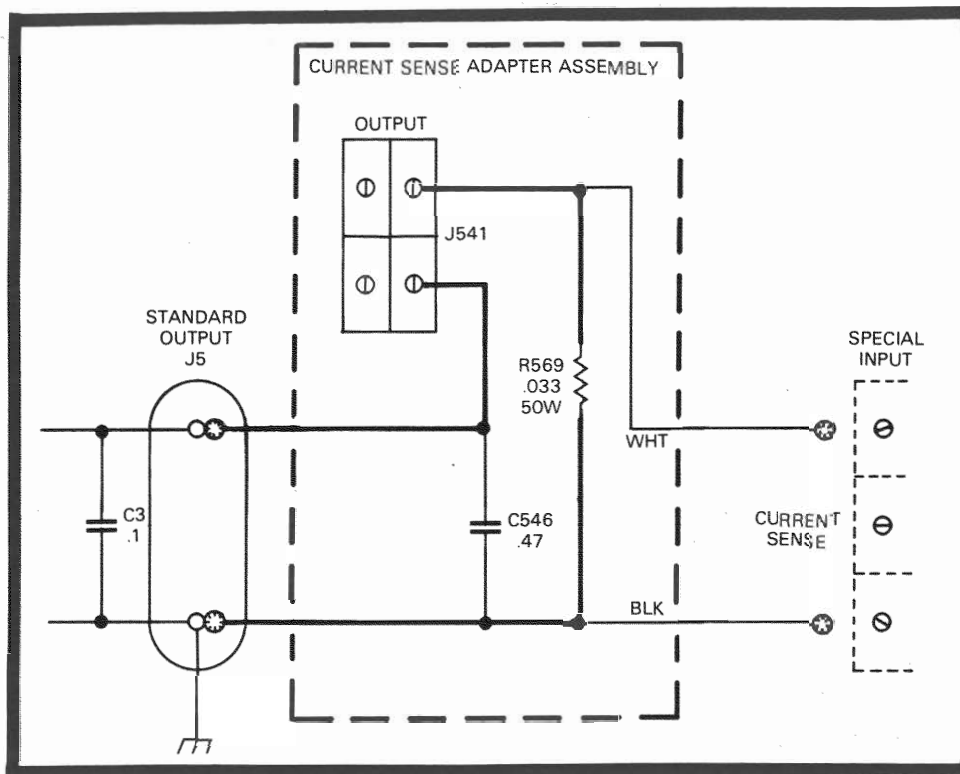
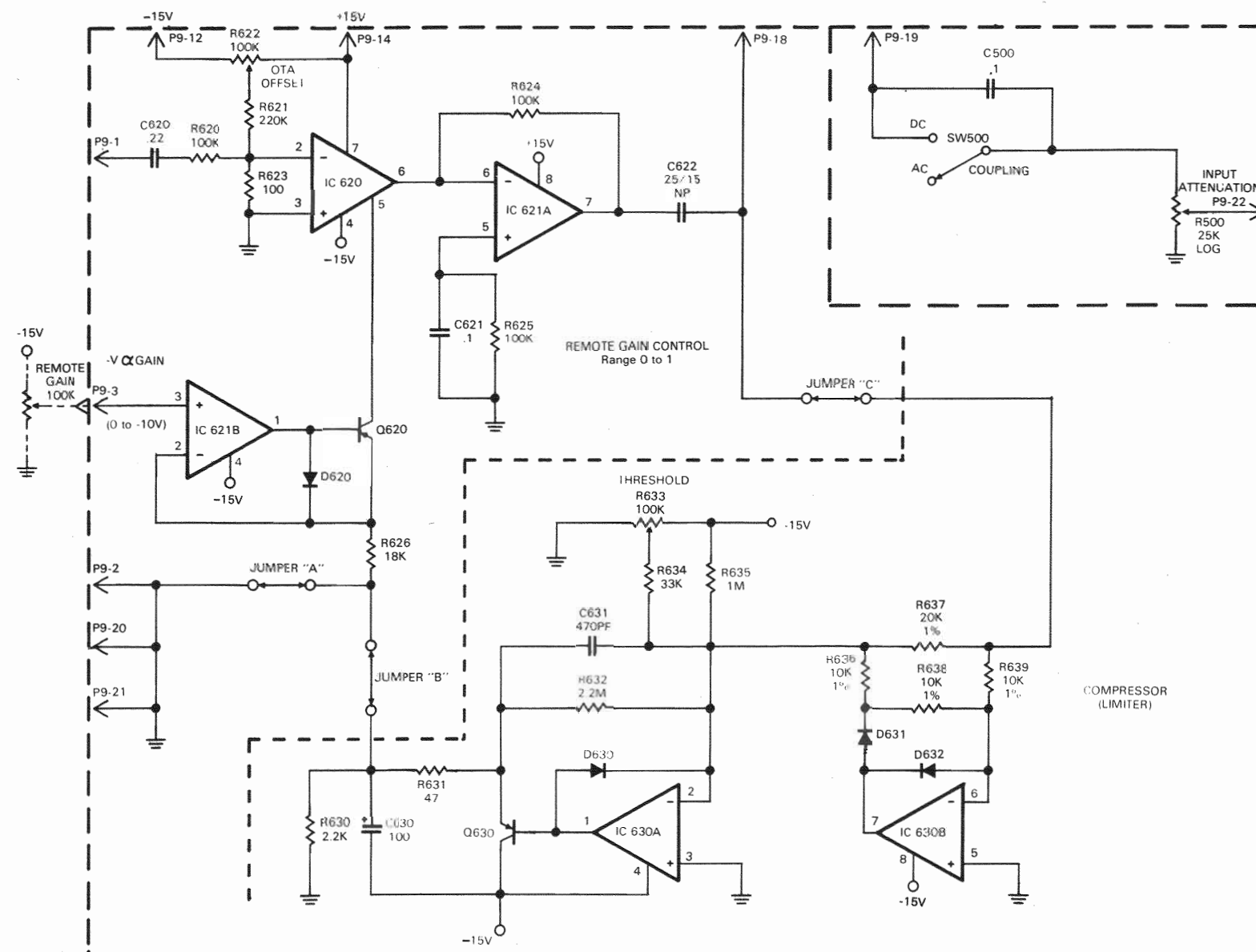

Fig. 5-5 Schematic, Current Sense Adapter Assembly

Reference Designation	Description	Crown Part No.	Other Information
	Capacitors		
C546	.47 MF 100V filmatic	3191	
	Resistors		
R569	.033 ohm 50 watt 3%		Dale RH-50
	Miscellaneous		
	Solder lug #6 hole	3163	
	CL-1 Resistor mount		
	CL-1 Resistor heat sink		
	.75 Fiber shoulder washer	1548	
	PA1-1U TO-5 P sink	3820	
	.25-32 hex nut		
	4-40 x .375 RHS screw	1344	
	#4 Int. star lock washer	1824	
	1/2" x 1/4" fish paper	3894	
	4-40 hex nut	1938	
	8-32 hex spacer	1346	
J541	2-542 barrier block	2968	
	Solder lug .218 hole	2934	
	Solder lug .250 hole	3515	
	#6 Int. star lock washer	1823	
	6-32 hex nut	1889	
	6-32 x .75 BHP screw	2135	
	8-32 x 1.25 THP screw	2268	
	#8 Int. star lock washer	1951	
	8-32 hex nut	1986	



5.7 Compressor Limiter with Remote Gain Control

The compressor limiter is designed for public address sound reinforcement use. It provides an attack time of 5 ms and a decay time of 200 ms. In addition, this circuit provides for remote gain control.

Circuit Description

A 3080 Operational transconductance amplifier is the key to circuit operation. The gain of the 3080 can be varied by varying its bias current. This is accomplished by the current amplifier Q620 and IC621B. The control voltage source is provided by a precision detector circuit IC630B and a DC amplifier IC630A. The output is buffered by IC621A which also provides signal to the precision detector. Remote gain control can be achieved by applying 0 to -10V to the non-inverting side of IC621B current amplifier.

NOTES:

1. This circuit is designed to be "breadboarded" on the standard plug-in module, PC #7931. A typical layout is provided.
2. Parts shown within the heavy dashed line are included on the standard plug-in assembly.
3. To use the Remote Gain control without the Limiter, install Jumper A, remove Jumpers B and C.
To use the Remote Gain control with the Limiter, remove Jumper A, and install Jumpers B and C.
4. A negative voltage (0 to -10V) at the α GAIN input (P9-3 via Special Input connector J2) will vary the gain from 0 to 1.

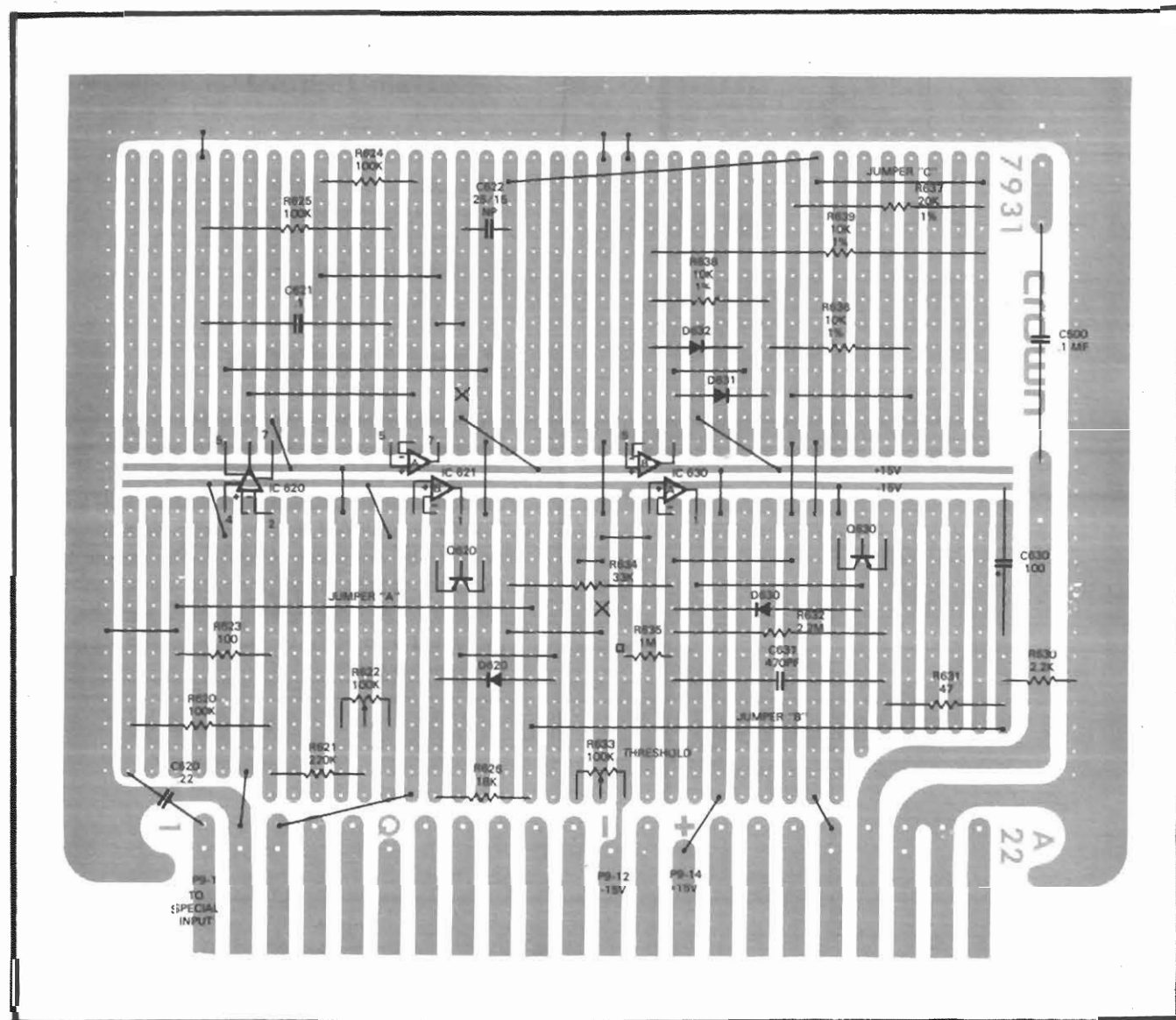

LEGEND:

- ● — = JUMPER WIRE
- □ — = COMPONENT STANDING ON END
- X — = CUT TRACE
- VIEW FROM FOIL SIDE OF PC BOARD

Reference Designation

Description

Crown Part No.

Other Information

Compressor Limiter Addition

Resistors

R630	2.2K ohm ½ watt 5% CF	1036
R631	47 ohm ½ watt 5% CF	2528
R632	2.2M ohm	NA
R633	100K ohm ½ watt 5% CF	1027
R634	33K ohm ½ watt 5% CF	1623
R635	1M ohm ½ watt 10% Comp	2865
R636, R638, R639	10K ohm ½ watt 1% MF	2343
R637	20K ohm ½ watt 1% MF	3752

Capacitors

C630	100 MF 6V tant	3169
C631	470 PF mica	2511

Transistors

Q630	2N4250A	3786
------	---------	------

Diodes

D630, D631, D632	1N4148	3181
------------------	--------	------

Integrated Circuits

IC630A,B	RC4558 dual op-amp	3919
----------	--------------------	------

Remote Gain Control

Resistors

R620, R622, R624, R625	100K ohm ½ watt 5% CF	1027
R621	220K ohm ¼ watt 5% CF	4219
R623	100 ohm ½ watt 5% CF	1007
R626	18K ohm ½ watt 10% Comp	1075

Capacitors

C620	.22 MF polycarb	3142
C621	.1 MF 200V filmatic	2938
C622	25 MF 15V NP vert	3186

Transistors

Q621	2N4250A	3786
------	---------	------

Diodes

D621	1N4148	3181
------	--------	------

Integrated Circuits

IC620	3080	NA
IC621A,B	JRC4558 dual op amp	3919

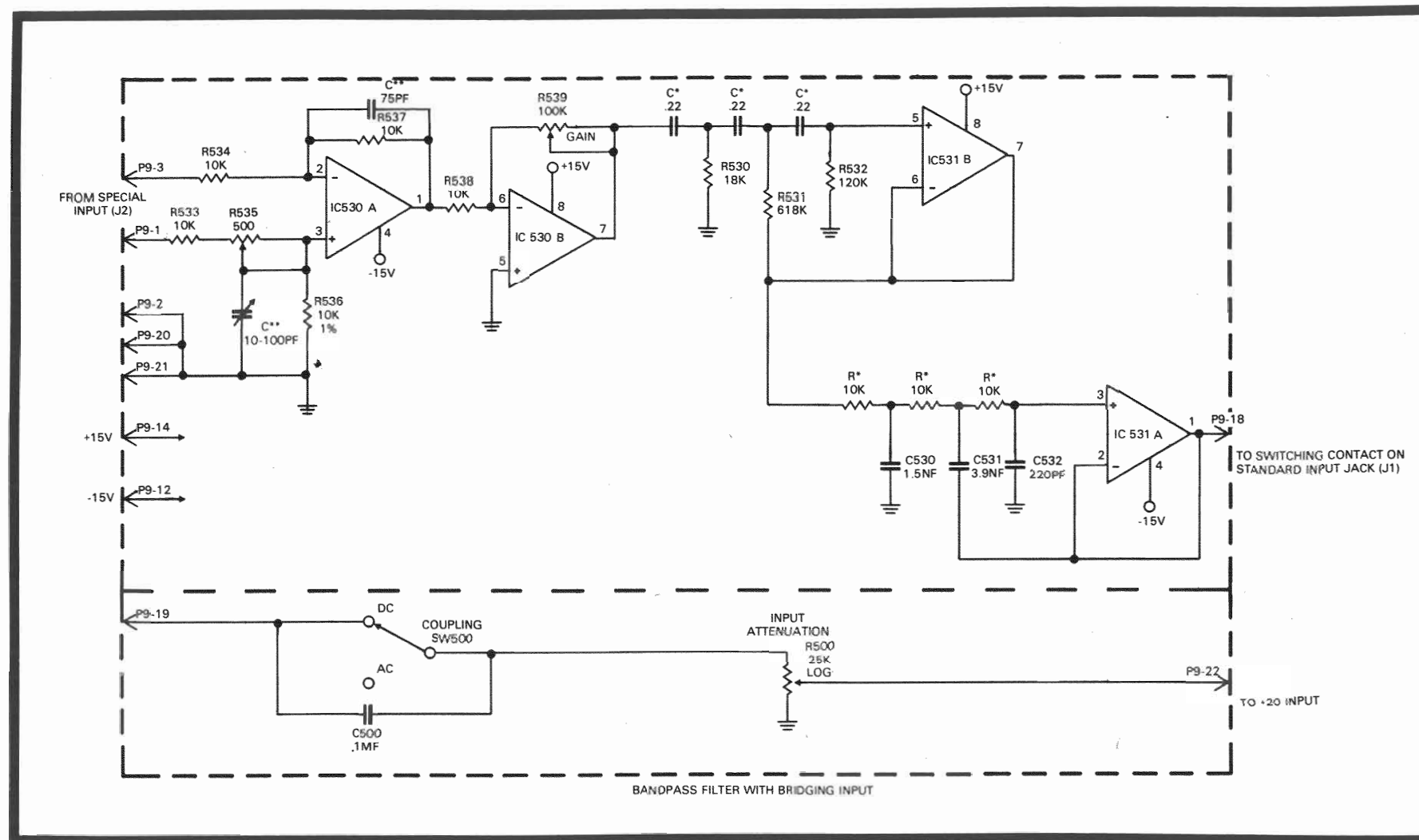

5.8 Bandpass Filter with Bridging Input

This circuit is identical to the PA Option, Section 5.3, but does not have the front panel filter function selector switch. This is designed as a fixed bandpass filter with cut-off frequencies determined by using the formulas in the notes. The gain control may be mounted on the plug-in front panel between R500 and SW500 if desired.

Circuit Description

A balanced input is provided by one-half of a 4558 operational amplifier providing unity gain. R535 provides common-mode rejection adjustment for this stage. The other half of the 4558 provides driving power for the 3-pole Butterworth filters. R539 controls the gain of this stage. Again a 4558 makes up the two filter sections. With values of C*, R530, R531, R532 and R*, C530, C531, C532 shown; $f_h = 30$ Hz, and $f_l = 15$ KHz.

NOTES:

1. This circuit is designed to be "breadboarded" on the standard plug-in module, PC #7931. A typical layout is provided.
2. The parts shown below the heavy dashed line are included on the standard plug-in assembly.
3. R* and C* are chosen according to the following general limitations:
 - a. $2K < R^* < 330K$
 - b. $R530 > 2K$
 - c. $R532 < 1M$
4. With valid values of R* and C*, R530, R531, R532, and C530, C531, and C532 are chosen according to the following formulas:

$R530 = \frac{.7184}{2\pi f_h C^*}$	$C530 = \frac{1.392}{2\pi f_l R^*}$
$R531 = \frac{.2820}{2\pi f_h C^*}$	$C531 = \frac{3.546}{2\pi f_l R^*}$
$R532 = \frac{4.941}{2\pi f_h C^*}$	$C532 = \frac{.2024}{2\pi f_l R^*}$

when f_h = highpass cutoff
 f_l = lowpass cutoff
5. The jumper from Pin 18 to Pin 20 on the standard plug-in module must be removed before the circuit will operate.
6. If a plug is inserted into the standard input jack (J1), the bandpass filter is disconnected.
7. C** may be deleted if HF CMR Adj. is not needed.

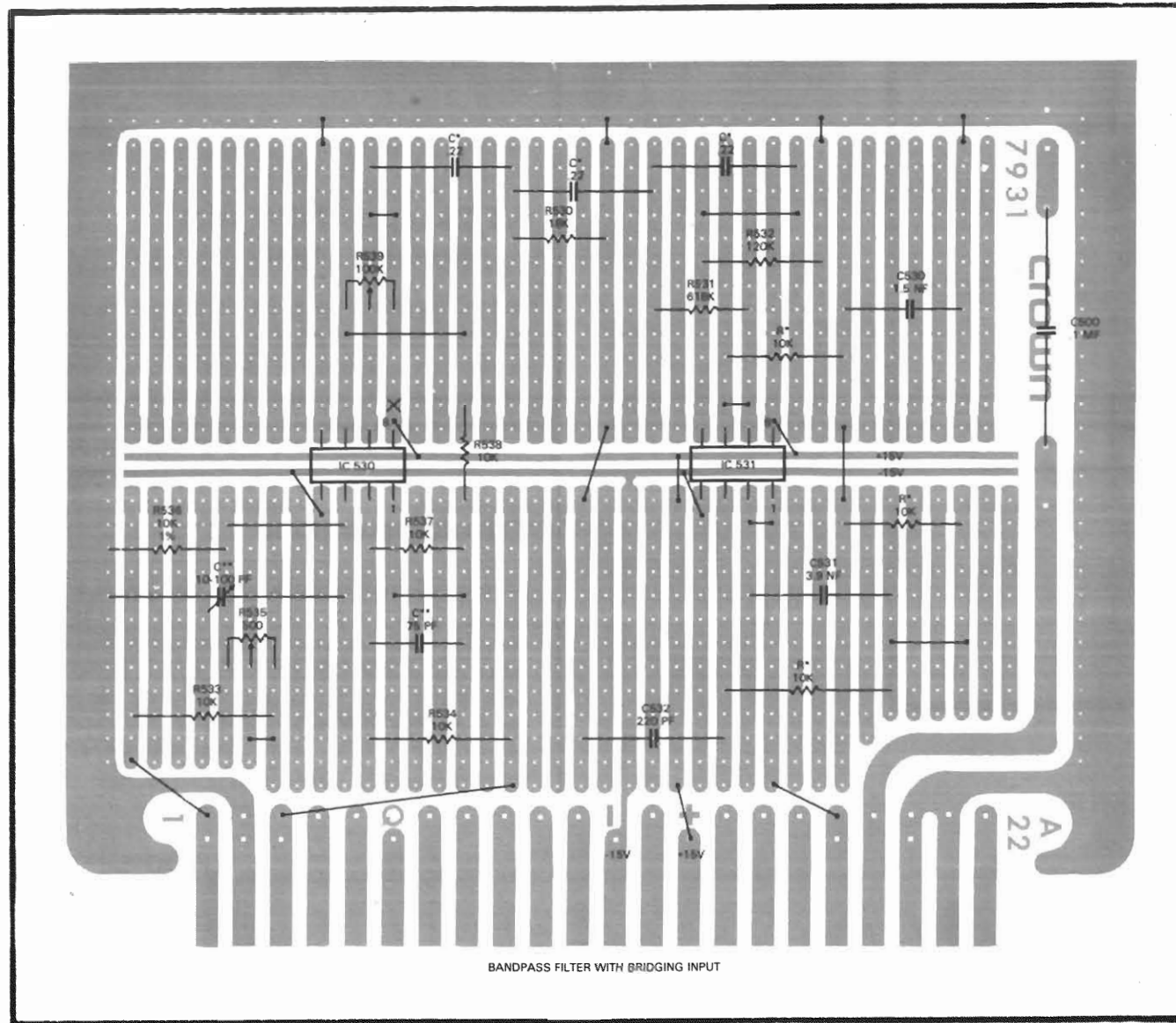

LEGEND:

- ● — = JUMPER WIRE
- □ — = COMPONENT STANDING ON END
- X — = CUT TRACE
- VIEW FROM FOIL SIDE OF PC BOARD

Reference Designation

Description

Crown Part No.

Other Information

Resistors

R530	18K ohm ½ watt 5% CF	1075
R531	618K ohm	NA
R532	120K ohm ¼ watt 5% CF	4214
R533, R534, R537, R538, R*	10K ohm ½ watt 5% CF	1035
R535	500 ohm 10 watt 10% wire	3624
R536	10K ohm ½ watt 1% MF	2343
R539	100K ohm ½ watt 5% CF	1027

Capacitors

C530	1.5 NF 200V filmatic	3089
C531	3.9 NF 200V filmatic	4151
C532	220 PF	NA
C*	220 MF 40V axial	4147
C**	75 PF	NA
C**	10-100 PF 467 Arco trimmer cap	1256

Integrated Circuits

IC530A,B IC531A,B	RC4558 Dual op amp	3919
----------------------	--------------------	------

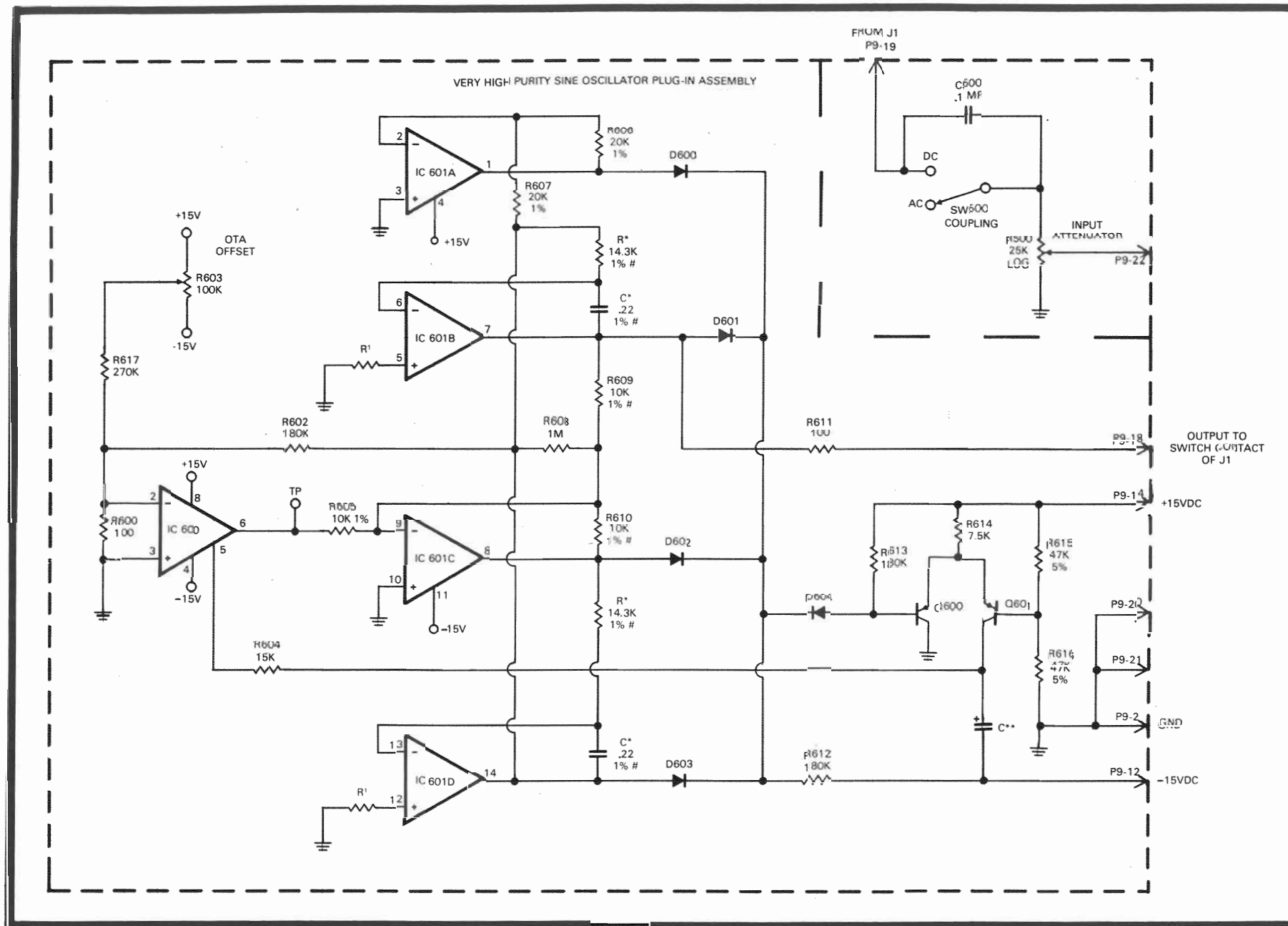

NOTES:

1. This circuit is designed to be "breadboarded" on the standard plug-in module, PC #7931. A typical layout is provided.
2. Parts shown within the heavy dashed line are included on the standard plug-in assembly.
3. General design considerations:
 - $f_{osc} = \frac{1}{2\pi R^* C^*}$
 - all six components marked 1% # are matched $\pm 1\%$.
 - C* should be of low D type (i.e. polycarbonate, mica, polystyrene).
 - $10K < R^* < 1M$, metal film type
 - $R^1 = 0 \text{ ohm}$ if $R^* < 20K$
 - $R^1 \approx R (\pm 10\%)$ if $R^* > 20K$
 - C** in farads $\approx .01 R^* C^*$
4. OTA Offset (R603) is adjusted for zero DC or zero second harmonic at TP.

5.9 Very High Purity Sine Oscillator

This circuit is designed for fixed frequency operation, providing ultra low distortion sine waves for input to the M-600. Typical THD values should be .0001% at 1KHz and .0002% at 5KHz.

Circuit Description

This is a four stage sine wave oscillator with the last two stages controlled by a 3080 operational transconductance amplifier. Signal from each stage is detected and put through a current amplifier to control the 3080. Follow the design considerations in the notes to determine values for R* and C*.

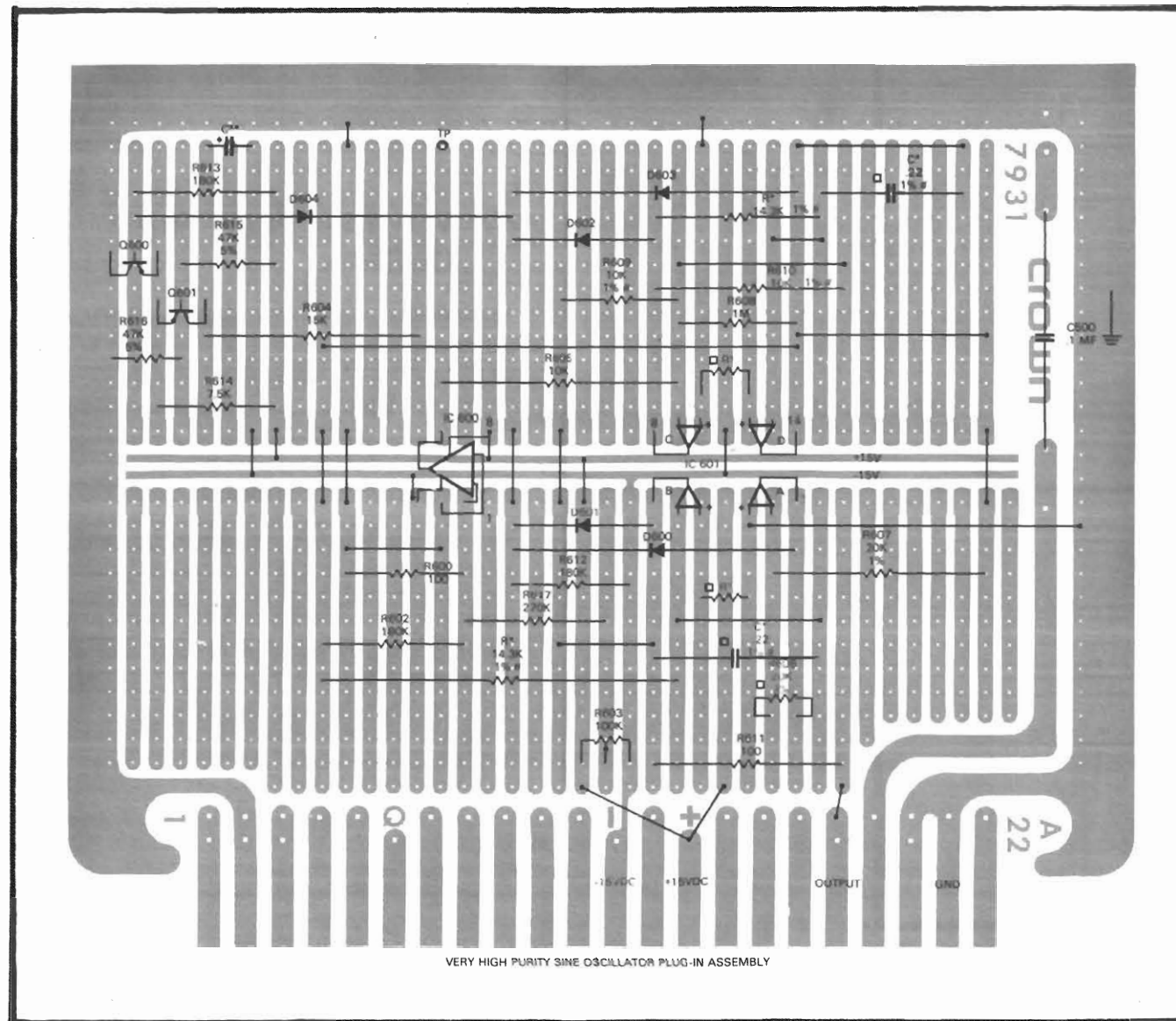

LEGEND:

- ● — = JUMPER WIRE
- □ — = COMPONENT STANDING ON END
- X — = CUT TRACE
- VIEW FROM FOIL SIDE OF PC BOARD

Reference Designation	Description	Crown Part No.	Other Information
Resistors			
R600, R611	100 ohm ½ watt 5% CF	1007	
R602, R612, R613	180K ohm ¼ watt 5% CF	2884	
R603	100K ohm ½ watt 5% CF	1027	
R604	15K ohm ½ watt 5% CF	1064	
R605	10K ohm ½ watt 1% MF	2343	
R606, R607	20K ohm ½ watt 1% MF	3685	
R608	1M ohm ½ watt 10% comp	2805	
R609, R610	10K ohm ½ watt 1%* MF	2343	
R614	7.5K ohm	NA	
R615, R616	47K ohm ½ watt 5% MF	1996	
R1			
R*	14.3K ohm 1%*	NA	
Capacitors			
C*	220 MF 1%* 40V axial	4147	
C**	.01 x R* C* in farads		
Transistors			
Q600, Q601	2N4125	3625	
Diodes			
D600, D601, D602, D603, D604	1N4148	3181	
Integrated Circuits			
IC600	8030	NA	
IC601A, B, C, D	HA-4741 quad op amp	4160	

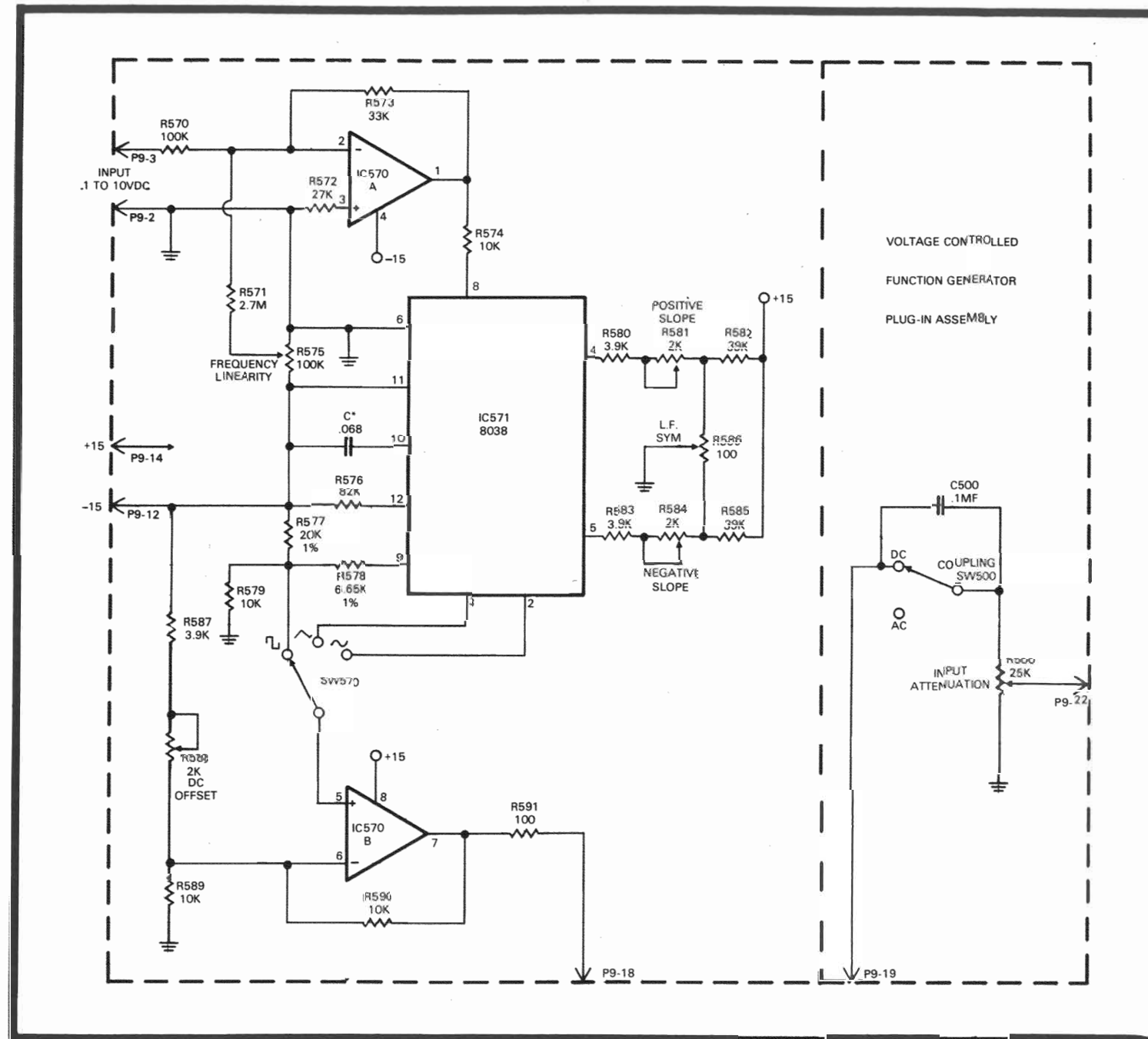

5.10 Voltage Controlled Function Generator

This circuit provides a sine wave, square wave and triangle wave generator input to the M-600. With the components shown, the frequency can be varied from 10Hz to 1KHz with a sine distortion of approximately 1%.

Circuit Description

The generator is built around the 8038 function generator chip. The voltage amplifier consisting of IC570A can be controlled either by remote or front panel controls. The IC570B is an output buffer.

NOTES:

1. This circuit is designed to be "breadboarded" on the standard plug-in module, PC #7931. A typical layout is provided.

2. Values for C* are chosen according to the following formulas:

$$C = \frac{.3 V_{in}}{10 R f}$$

where: V_{in} = input voltage (.1 to 10 VDC)

$R = 4.41K$ (nominal value of network between pins 4 and 5 of IC571)

f = desired frequency

3. C* may be switch selected for multiple ranges (with $V_{in} = .1$ to 10VDC)

1Hz to 100Hz, C* = .63MF

10Hz to 1KHz, C* = .068MF

100Hz to 10KHz, C* = 6.8NF

1KHz to 100KHz, C* = .68NF

10KHz to 1MHz, C* = 68PF

4. Parts shown right of the heavy dashed line are included on the standard input plug-in assembly.

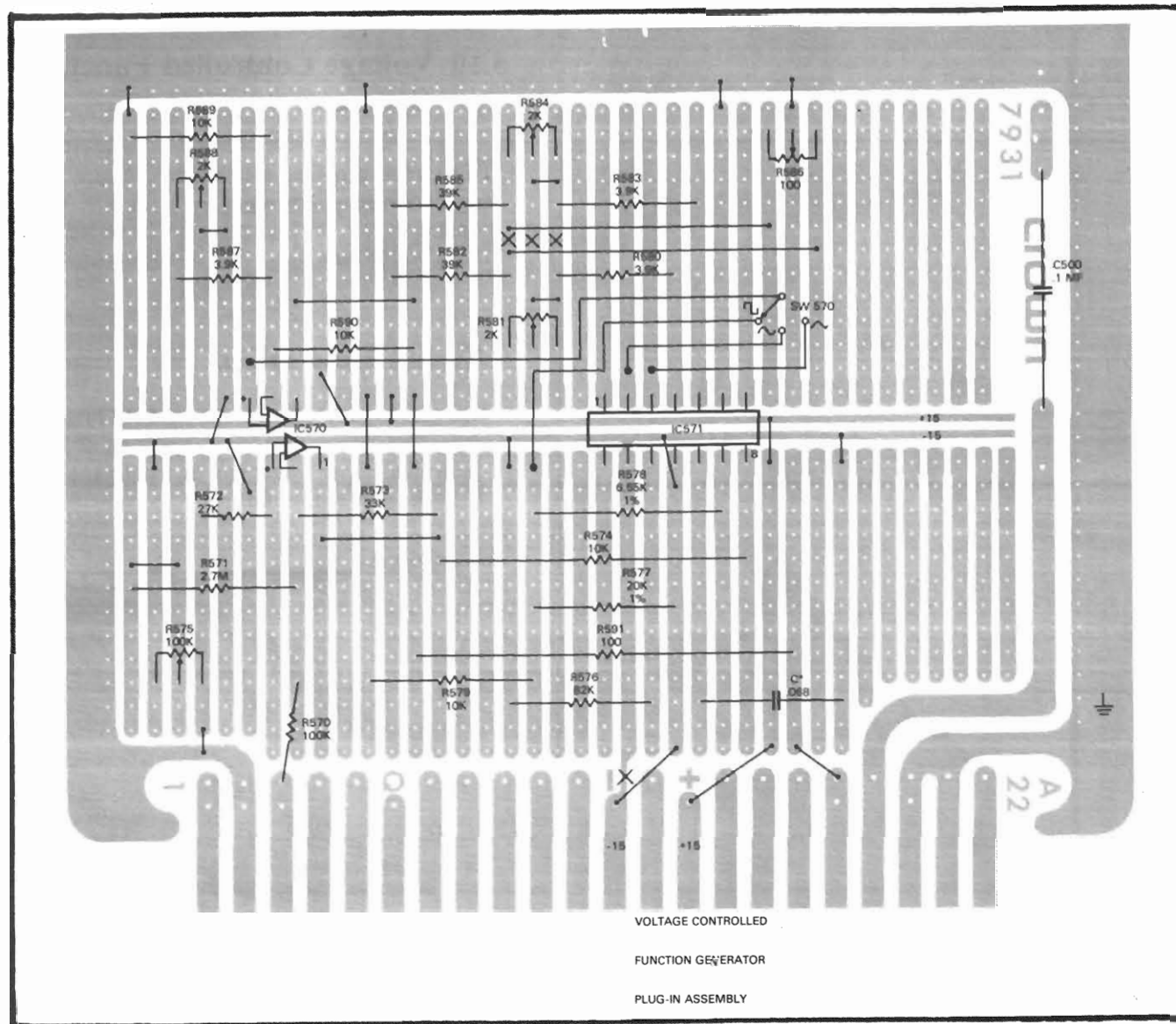

LEGEND:

- ● — = JUMPER WIRE
- □ — = COMPONENT STANDING ON END
- X — = CUT TRACE
- VIEW FROM FOIL SIDE OF PC BOARD

Reference Designation	Description	Crown Part No.	Other Information
Resistors			
R570	100K ohm 1/2 watt 5% CF	1027	
R571	2.7M ohm 1/4 watt 5% CF	2634	
R572	27K ohm 1/2 watt 5% CF	1056	
R573	33K ohm 1/2 watt 5% CF	1623	
R574, R579	10K ohm 1/2 watt 5% CF	1035	
R589, R590			
R575	100K ohm helipot trim	NA	No CPN available Freq. linearity
R576	82K ohm 1/4 watt 10% comp	3808	
R577	20K ohm 1/2 watt 1% MF	3752	
R578	6.65K ohm 1%	NA	
R580, R583	3.9K ohm 1/2 watt 5% CF	1059	
R587			
R581, R584	2K ohm helipot trim	3672	Positive slope Negative slope DC offset
R588			
R582, R585	39K ohm 1/2 watt 5% CF	1043	
R586	100 ohm helipot trim	3673	L.F. sym
R591	100 ohm 1/2 watt 5% CF	1007	
Capacitors			
C*	.068	NA	Selective
Integrated Circuits			
IC570A,B	RC4558 dual op amp	3919	
IC571	8038	NA	
Switches			
SW570		NA	

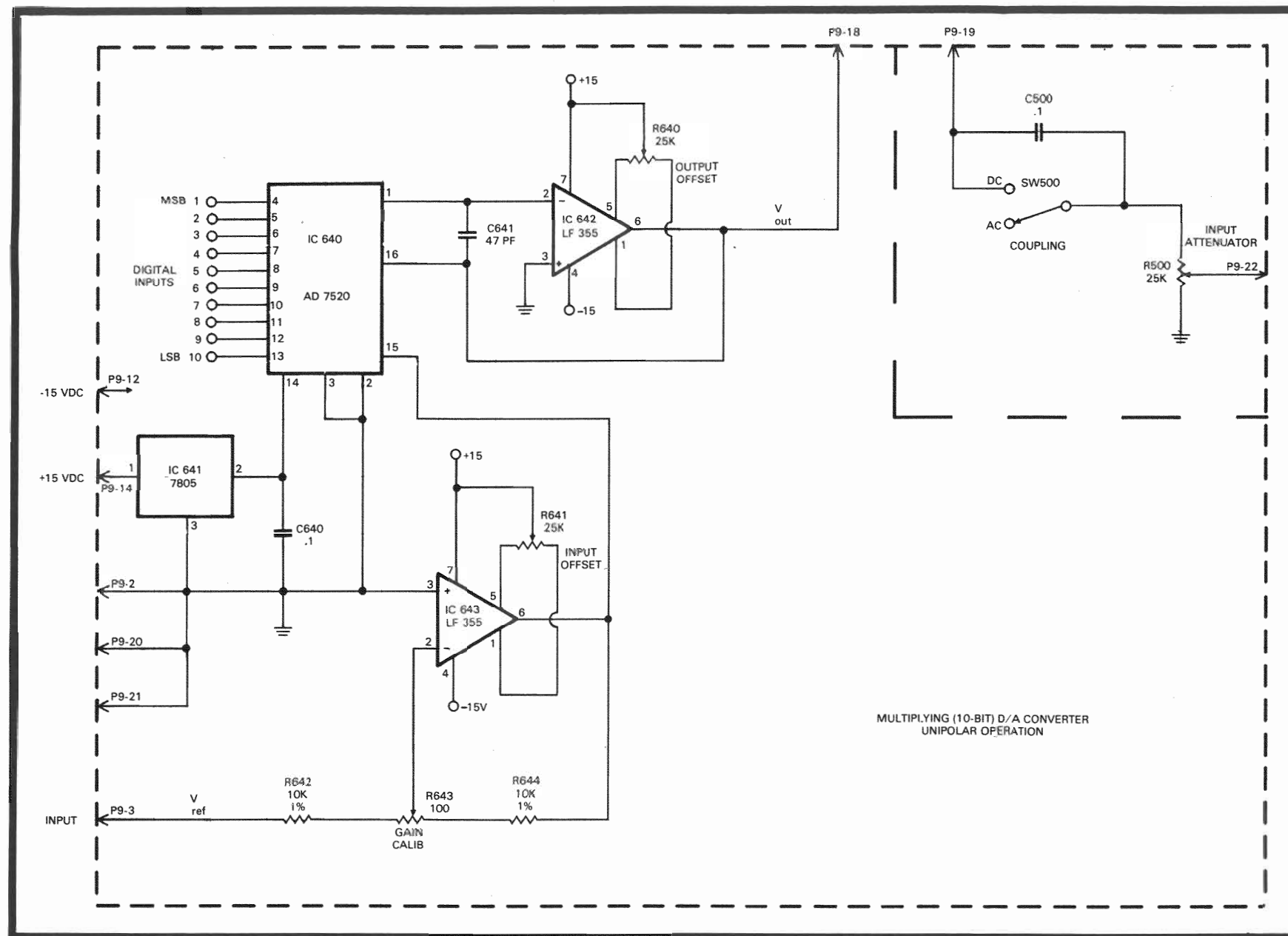

NOTES:

1. This circuit is designed to be "Breadboarded" on the standard input module, PC #7931. A typical layout is provided.
2. The 7520 D/A (CMOS) is made by Analog Devices. The desired linearity determines the suffix choice. (i.e. LN, KN, or JN).
3. Op-amps are National type LF355.
4. IC641 (7805) and C640 are used only with TTL compatible inputs. If input logic is +15V CMOS, pin 14 of IC640 should be connected to the +15V supply.
5. If this circuit is to be used as a digitally controlled gain control, the audio input signal is applied to V_{ref} input.
If the converter is to be used to produce a programmed DC supply, a DC reference potential is applied to V_{ref} input.
6. An input connector for the digital information can be mounted on the M-600 rear control panel near the two normal inputs. An interconnecting cable can then be routed to P9 (22-pin precision connector) at the plug-in input assembly.

5.11 Multiplying D/A Converter — Unipolar Operation

The following circuit digitally controls the input level to the M-600. This circuit (unipolar operation) is one of three similar designs. (See also 5.11 and 5.12)

Circuit Design

The design uses a multiplying D/A converter (10 bit), and conventional operational amplifiers. For TTL compatibility, an IC voltage regulator is also used. For adjustment, follow the adjustment procedures below.

Zero Offset Adjustment

1. Tie all digital inputs to the AD7520 to GND potential.
2. Adjust the OUTPUT OFFSET trimpot for $0V \pm 1mV$ at V_{out} .
3. Tie V_{ref} input to GND potential.
4. Adjust the INPUT OFFSET trimpot for $0V \pm 1mV$ at pin 15 of the AD7520 (IC640).

Gain Adjustment (Variable Reference)

1. Tie all digital inputs to the AD7520 to logic "1".
2. Adjust the GAIN CALIB trimpot for $V_{ref} \times (1 - 2^{-10})$ at V_{out} .

$$V_{out} = V_{ref} \times (\text{binary input}) \times 2^{-10}$$

DIGITAL INPUT	ANALOG OUTPUT
1111111111	$+V_{REF}(1 - 2^{-10})$
1000000001	$+V_{REF}(1/2 + 2^{-10})$
1000000000	$\frac{+V_{REF}}{2}$
0111111111	$+V_{REF}(1/2 - 2^{-10})$
0000000001	$+V_{REF}(2^{-10})$
0000000000	0

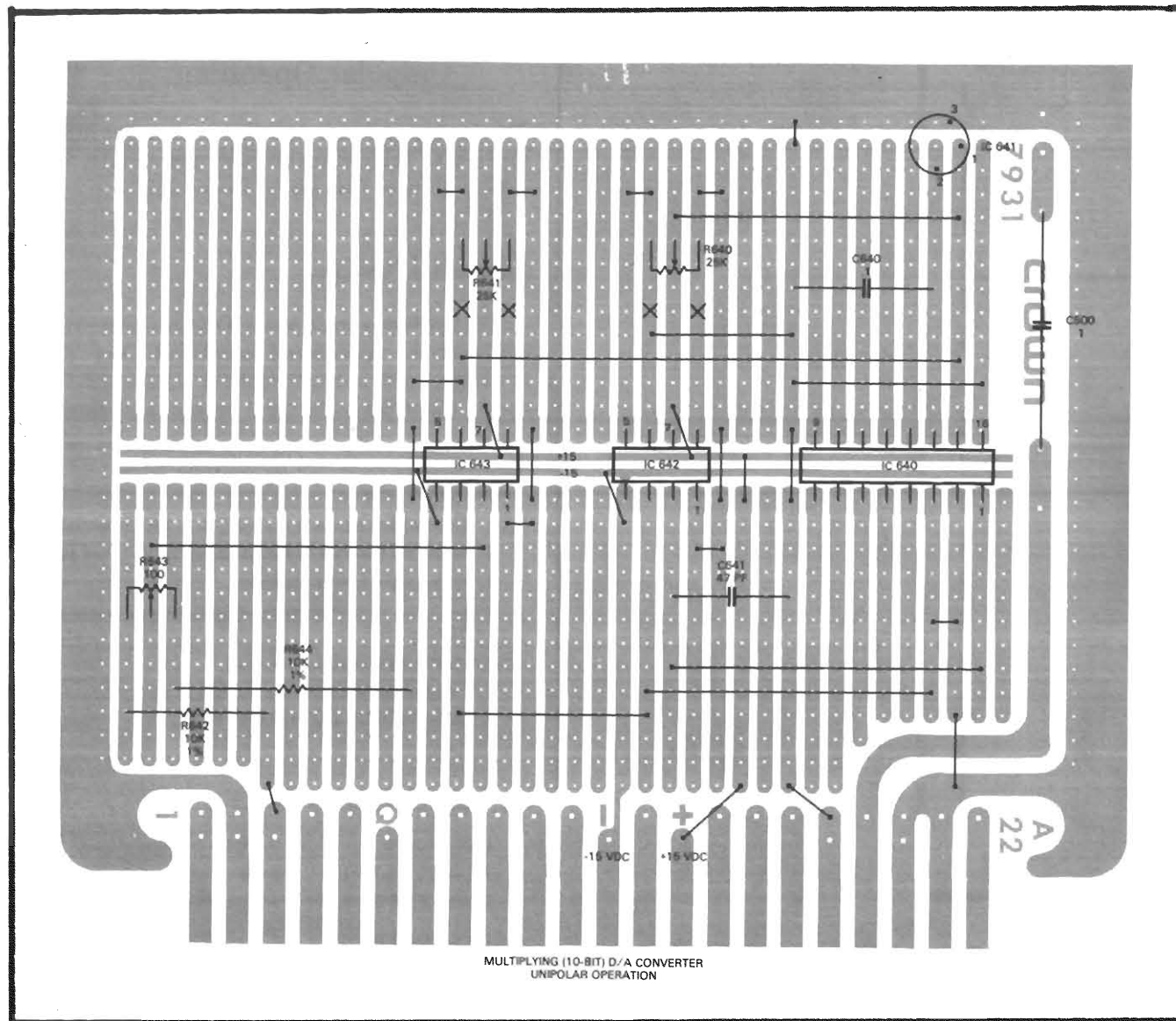

LEGEND:

- ● — = JUMPER WIRE
- □ — = COMPONENT STANDING ON END
- X — = CUT TRACE
- VIEW FROM FOIL SIDE OF PCB

Reference Designation	Description	Crown Part No.	Other Information
Resistors			
R640, R641	25K ohm pot	NA	Output, input, offset
R642, R644	10K ohm ½ watt 1% MF	2343	
R643	100 ohm helipot trim	3673	
Capacitors			
C640	47 PF mica	3409	
C641			
Integrated Circuits			
IC640	AD7520	NA	
IC641	7805	NA	
IC642, IC643	LF355	NA	

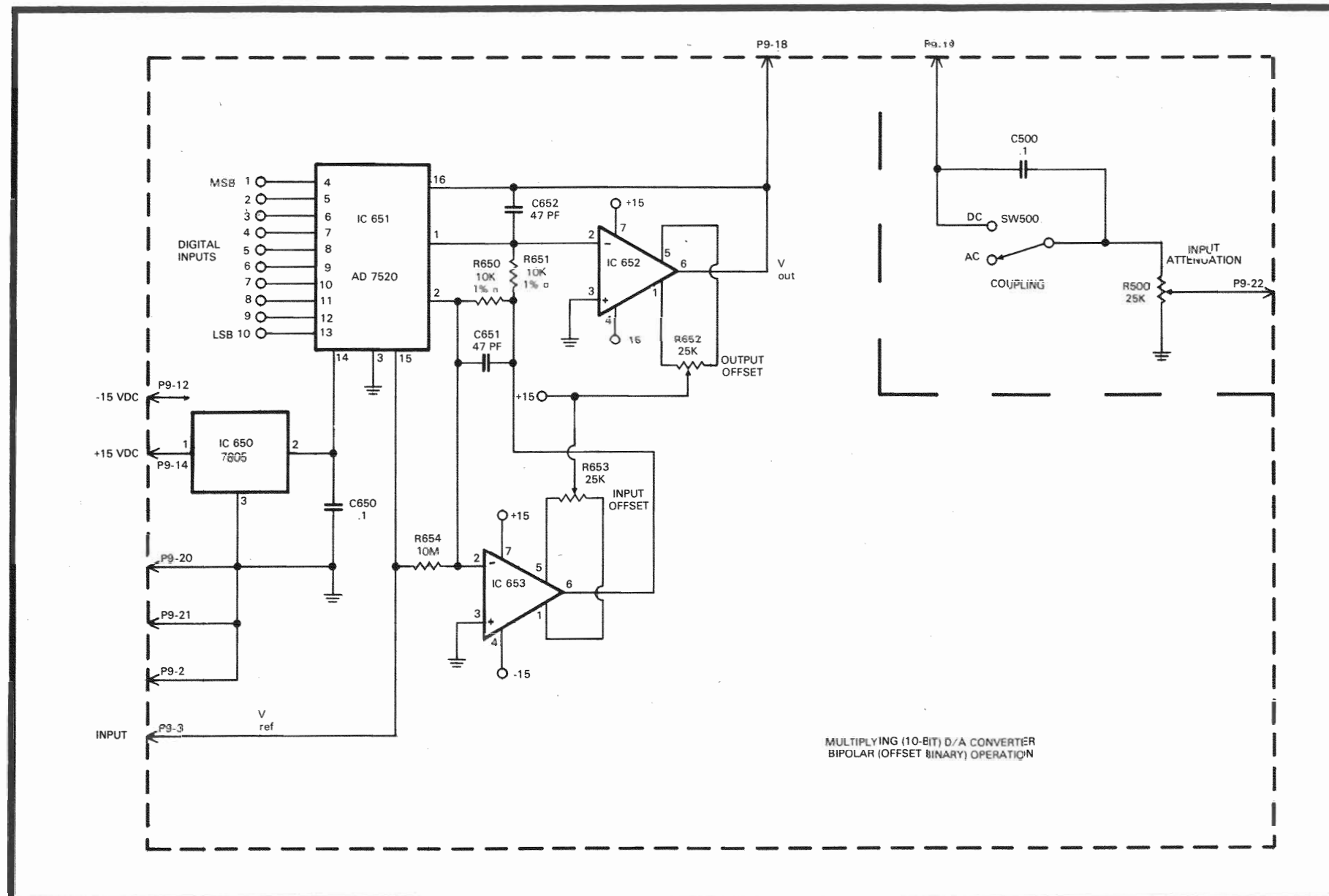

NOTES:

1. This circuit is designed to be "Breadboarded" on the standard input module, PC #7931. A typical layout is provided.
2. The 7520 D/A (CMOS) is made by Analog Devices. The desired linearity determines the suffix choice. (i.e. LN, KN, or JN).
3. Op-amps are National type LF 355.
4. Resistors R650 and R651 (marked □) are matched to the non-linearity spec of the AD7520, IC651.
5. IC650 (7805) and C650 are used only with TTL compatible inputs. If input logic is +15V CMOS, pin 14 of IC651 should be connected to the +15VDC supply.
6. If this circuit is to be used as a digitally controlled gain control, the audio input signal is applied to V_{ref} input.
When used to produce a programmed DC supply, a DC reference potential is applied to V_{ref} input.
7. An input connector for the digital information can be mounted on the M-600 rear control panel near the two normal inputs. An interconnecting cable can then be routed to P9 (22-pin precision connector) at the plug-in input assembly.

5.12 Multiplying D/A Converter — Bipolar Operation (Offset Binary)

The following circuit digitally controls the input level to the M-600. This circuit (bipolar offset binary operation) is one of three similar designs. (See also 5.10 and 5.12)

Circuit Description

The design uses a multiplying D/A converter (10 bit), and conventional operational amplifiers. For TTL compatibility, an IC voltage regulator is also used. For adjustment, follow the adjustment procedures below.

Offset Adjustment

1. Make V_{ref} approximately +10V.
2. Tie all digital inputs to logic "1".
3. Adjust INPUT OFFSET trimpot for 0V ±1mV at pin 6 of IC653.
4. Tie MSB (Bit-1) to logic "1", all other bits to ground (1000000000).
5. Adjust OUTPUT OFFSET trimpot for 0V ±1mV at V_{out}.

Gain Adjustment (Fixed Reference)

1. Tie all digital inputs to the AD7520 to logic "1".
2. Adjust V_{ref} for required full scale output at V_{out}.

Gain Adjustment (Variable Reference)

1. Tie all digital inputs to the AD7520 to logic "1".
2. To increase V_{out}, place a resistor in series with the amplifier output terminal and pin 16, R_{feedback} of the AD7520. (R=0 to 5 K ohm).
3. To decrease V_{out}, place a resistor in series with V_{ref} and pin 15, the reference input terminal. (R=0 to 5 K ohm).

$$V_{out} = V_{ref} \times (1 - (\text{binary input}) \times 2^{-9})$$

DIGITAL INPUT	ANALOG OUTPUT
1111111111	-V _{REF} (2 ⁻⁹ - 1)
1000000001	-V _{REF} (2 ⁻⁹)
1000000000	0
0111111111	V _{REF} (2 ⁻⁹)
0000000001	V _{REF} (1 - 2 ⁻⁹)
0000000000	V _{REF}

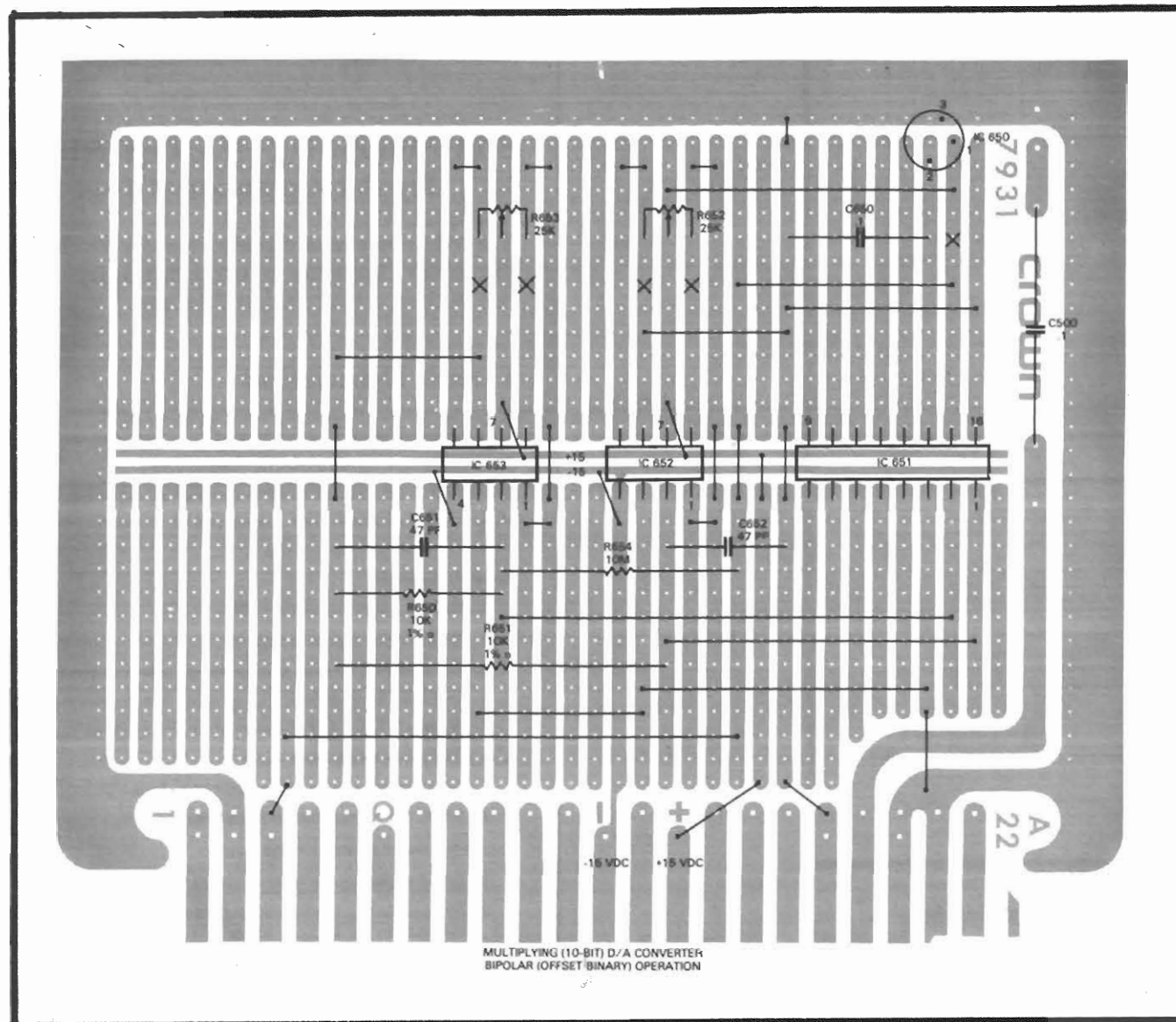

LEGEND:

- ● — = JUMPER WIRE
- □ — = COMPONENT STANDING ON END
- X — = CUT TRACE
- VIEW FROM FOIL SIDE OF PC BOARD

Reference Designation	Description	Crown Part No.	Other Information
Resistors			
R650, R651	10K ohm ½ watt 1% MF	2343	Output, input, offset
R652, R653	25K ohm pot	NA	
R654	10M ohm ¼ watt 5% CF	3221	
Capacitors			
C650	.1 MF 200V Filmatic	2938	
C651, C652	47 PF mica	3409	
Integrated Circuits			
IC650	7805	NA	
IC651	AD7520	NA	
IC652, IC653	LF 355	NA	

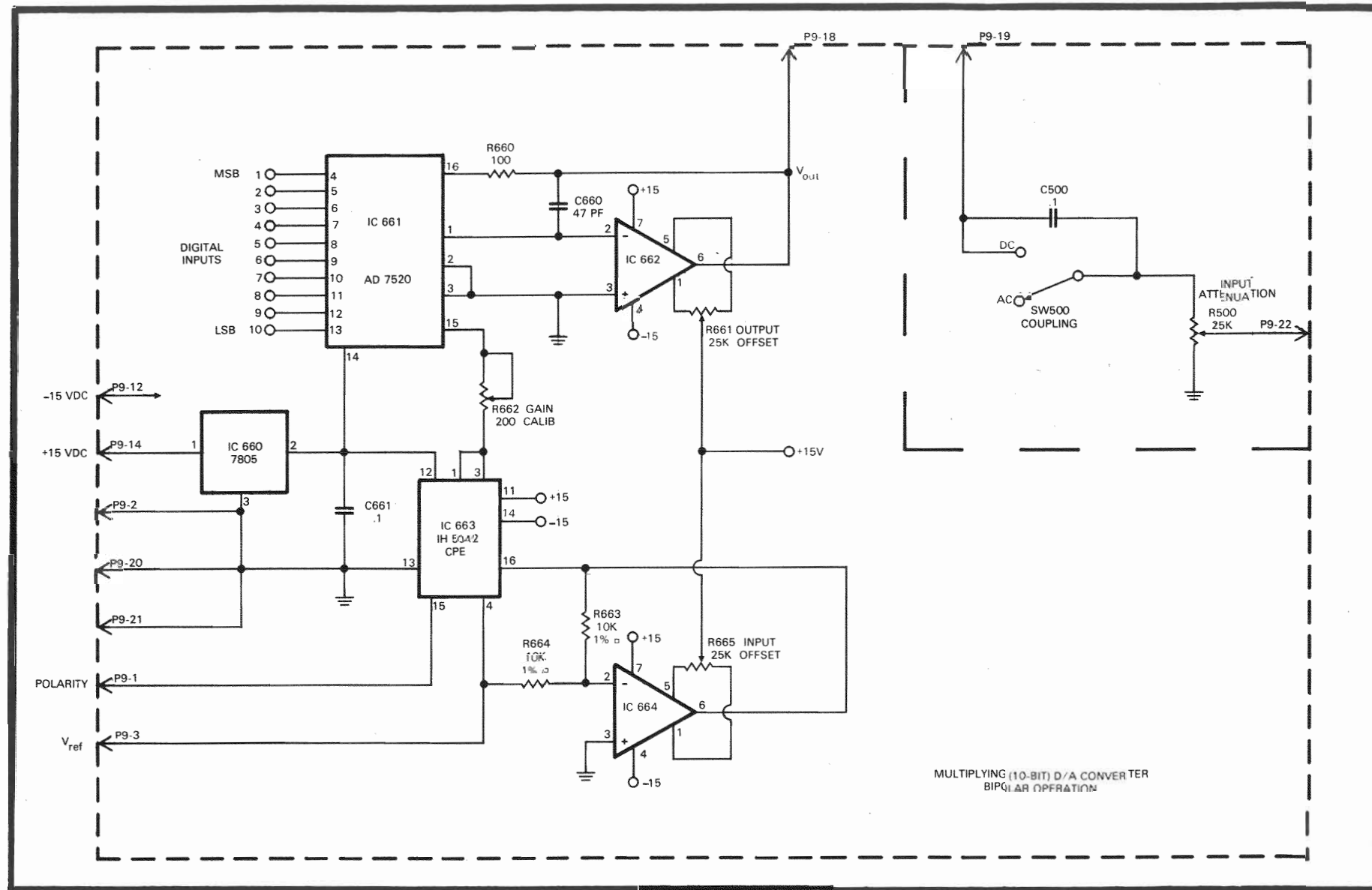

MULTIPLYING (10-BIT) D/A CONVERTER
BIPOLAR OPERATION

NOTES:

1. This circuit is designed to be "breadboarded" on the standard input module, PC #7931. A typical layout is provided.
2. The 7520 D/A (CMOS) is made by Analog Devices. The desired linearity determines the suffix choice. (i.e. LN, KN, or JN)
3. Components marked 1% are matched to the nonlinearity spec of the AD7520.
4. The 1H5042 is a CMOS SPDT analog switch made by Intersil.
5. Op-amps are National type LF355.
6. IC660 (7805) and C661 are used only with TTL compatible input. If input logic is +15V CMOS, pin 14 of IC661 should be connected to the +15VDC supply.
7. If this circuit is to be used as a digitally controlled gain control, the audio signal is applied to V_{ref} input.
When used to produce a programmed DC supply, a DC reference potential is applied to V_{ref} input.
8. An input connector for the digital information can be mounted on the M-600 rear control panel near the two normal inputs. An interconnection cable can then be routed to P9 (22-pin precision connector) at the plug-in input assembly.

5.13 Multiplying D/A Converter — Bipolar Operation

The following circuit digitally controls the input level to the M-600. This circuit (bipolar operation) is one of three similar designs. (See also 5.10 and 5.11)

Circuit Description

The design uses a multiplying D/A converter (10 bit), and conventional operational amplifiers. An IC analog switch is used for polarity control. For TTL compatibility, an IC voltage regulator is also used. For adjustment, follow the adjustment procedures below.

Zero Offset Adjustment

1. Tie all digital inputs to the AD7520 to GND potential.
2. Adjust the OUTPUT OFFSET trimpot for $0V \pm 1mV$ at V_{out} .
3. Tie V_{ref} input to GND potential.
4. Adjust the INPUT OFFSET trimpot for $0V \pm 1mV$ at pin 16 of IC663.

Gain Adjustment (Variable Reference)

1. Tie all digital inputs to logic "1".
2. Adjust the GAIN CALIB trimpot for $V_{ref} \times (1 - 2^{-10})$ at V_{out} .

$$V_{out} = V_{ref} \times (\text{binary input}) \times 2^{-10} \text{ for "1" on polarity bit}$$

$$V_{out} = -V_{ref} \times (\text{binary input}) \times 2^{-10} \text{ for "0" on polarity bit}$$

DIGITAL INPUT	ANALOG OUTPUT
1111111111	$\pm V_{REF} (1 - 2^{-10})$
1000000001	$\pm V_{REF} (\frac{1}{2} + 2^{-10})$
1000000000	$\pm \frac{V_{REF}}{2}$
0111111111	$\pm V_{REF} (\frac{1}{2} - 2^{-10})$
0000000011	$\pm V_{REF} (2^{-10})$
0000000000	0

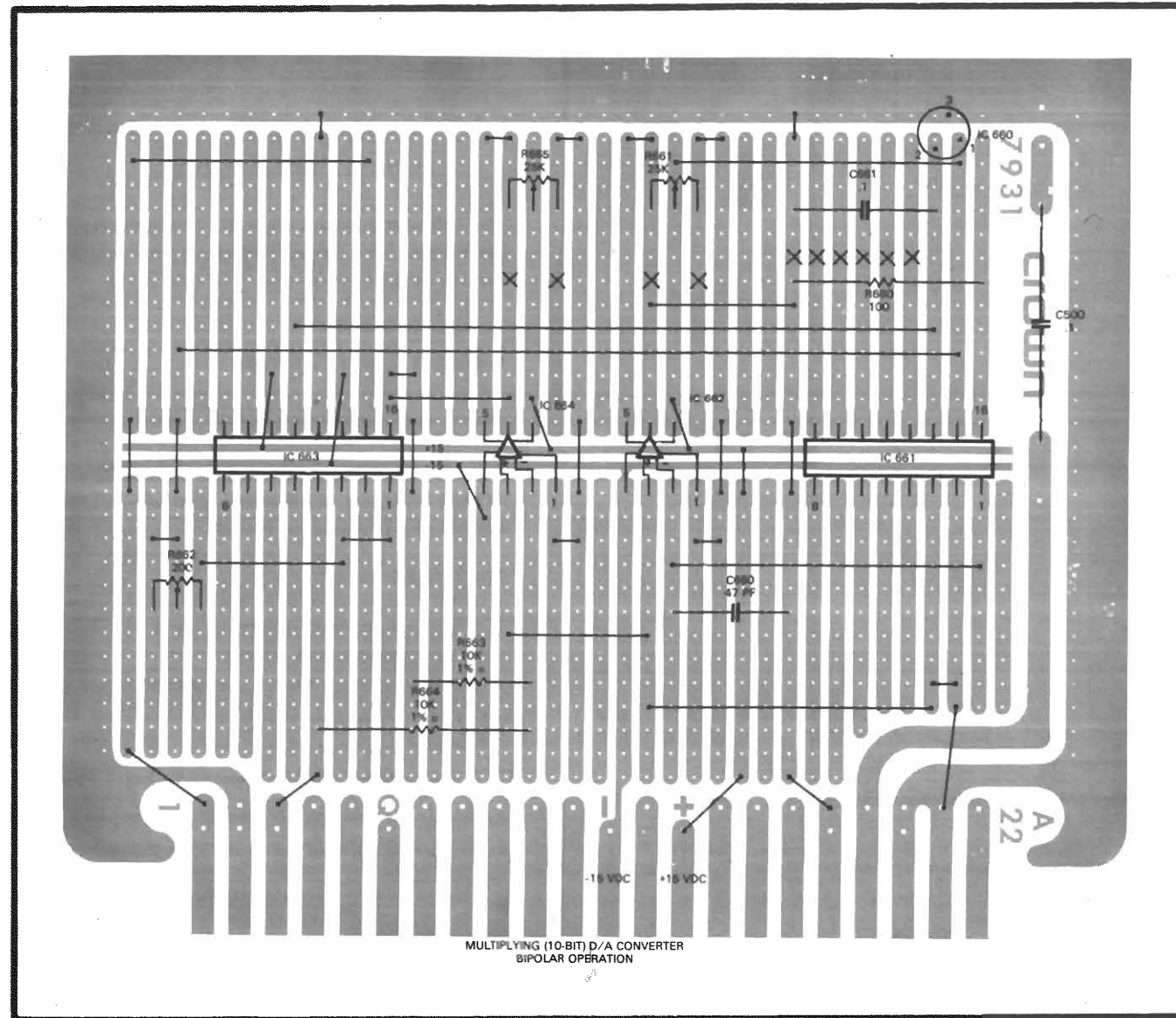

LEGEND:

- ● — = JUMPER WIRE
- □ — = COMPONENT STANDING ON END
- X — = CUT TRACE
- VIEW FROM FOIL SIDE OF PC BOARD

Reference Designation	Description	Crown Part No.	Other Information
Resistors			
R660	100 ohm 1/2 watt 5% CF	1007	
R661, R665	25K ohm pot	NA	
R662	200 ohm 1/4 watt 5% comp	3800	
R663, R664	10K ohm 1/2 watt 1% MF	2343	
Capacitors			
C660	47 PF mica	3409	
C661	.1 MF 200V Filmatic	2938	
Integrated Circuits			
IC660	7850	NA	
IC661	AD7520	NA	
IC662, IC664	LF355	NA	
IC663	IH 5042 CPE	NA	CMOS SPDT



CROWN
M-600 AMPLIFIER

SECTION 6. ILLUSTRATED PARTS LIST

6.1. General Information

This Section contains illustrations and parts lists for the Model M-600 Amplifier. When used in conjunction with the service, repair, and adjustment information in Section 7, the information in this Section will aid the service technician in rapidly and accurately identifying and replacing defective parts.

Most of the mechanical and structural type parts are illustrated and indexed on exploded view illustrations. Electrical and electronic parts shown on these illustrations are also identified by the circuit reference designation adjacent to the illustration. Both the index number and the reference designation are included in the parts listing in separate columns. The reference designations correspond to those shown in the schematic diagrams in Section 4 and on the wiring diagram in Section 7.

Electrical and electronic parts located on printed circuit boards are illustrated by schematic type symbols on printed circuit board representations. Again, the reference designations as they appear on the schematic diagrams in Section 4 are used on the illustrations and in the parts listings to identify parts. Miscellaneous mechanical type parts such as screws and nuts are not on the illustrations but are included in the parts lists with sufficient explanatory notes to clarify their use.

The quantity of each part used in each location is also shown in the parts listing. The quantity of bulk items (such as heatsink compound and tape) is indicated in the quantity column by AR (as required).

6.2. Standard and Special Parts

Many electrical and electronic parts and many attaching type parts used in the M-600 Amplifier are standard items stocked by and available from electronic supply houses or hardware suppliers. However, some electronic parts that appear to be standard are actually special. The special electronic parts are identified in the parts listings by the notation "selected by CROWN". This means that Crown has selected the item to meet specific requirements. A part ordered by the CROWN part number will assure an acceptable replacement. Structural items such as covers and panels are available only from CROWN.

6.3. Ordering Parts

When ordering parts for the M-600 Amplifier, be sure to give the Amplifier model and serial number and include the part description and CROWN part number from the parts list.

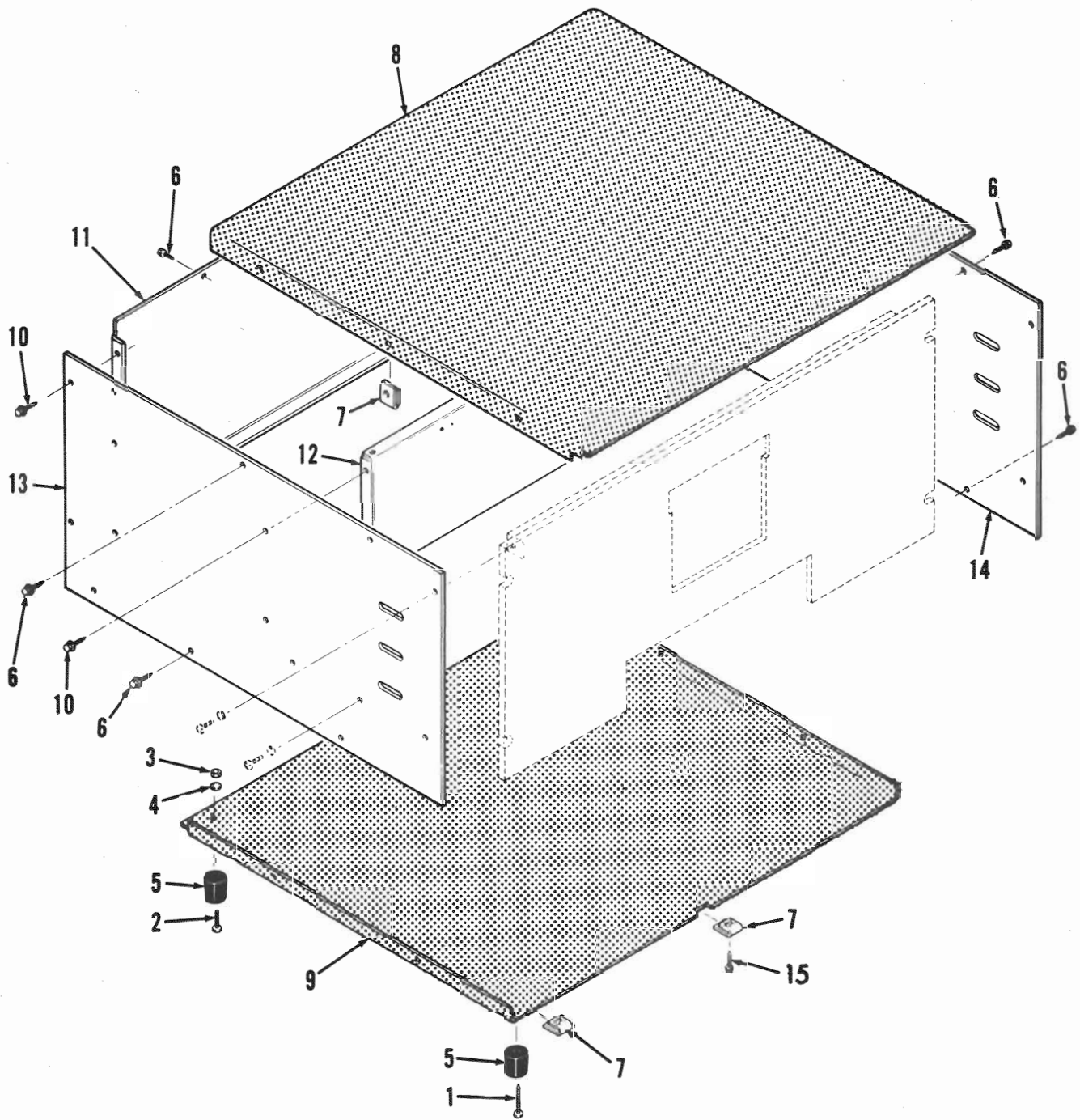

Fig. 6-1. Covers and Front Duct Panel



CROWN
M-600 AMPLIFIER

Parts List: Covers and Front Duct Panel

Index No.	Reference Designation	Description	Qty.	Crown Part No.	Other Information
1		Screw, pan head phillips, No. 8-18 X 1	2	2088	Mounts feet
2		Screw, truss head, phillips, No. 8-32 X 1	2	2269	Mounts feet
3		Nut, hex, No. 8-32	2	1986	Mounts feet
4		Lock washer, internal star, No. 8	2	1951	Mounts feet
5		Feet	4	2945	
6		Screw, washer head sheet metal, No. 8 X 5/8	17	2757	Mounts top and bottom covers
7		Speed nut C10163-8A4	16	3859	
8		Top cover, perforated	1	9548S	
9		Bottom cover, perforated	1	9547S	
10		Screw, slotted hex head sheet metal, No. 8-18 X 3/8	4	3957	Mounts back cover and front duct cover
11		Back cover	1	9546R	
12		Front duct panel	1	9523S	
13		Side cover	1	9519S	
14		Fan side cover	1	9518S	
15		#8-15 x 1/2" OHP SMT screw	1	2709	Mounts bottom cover at front center

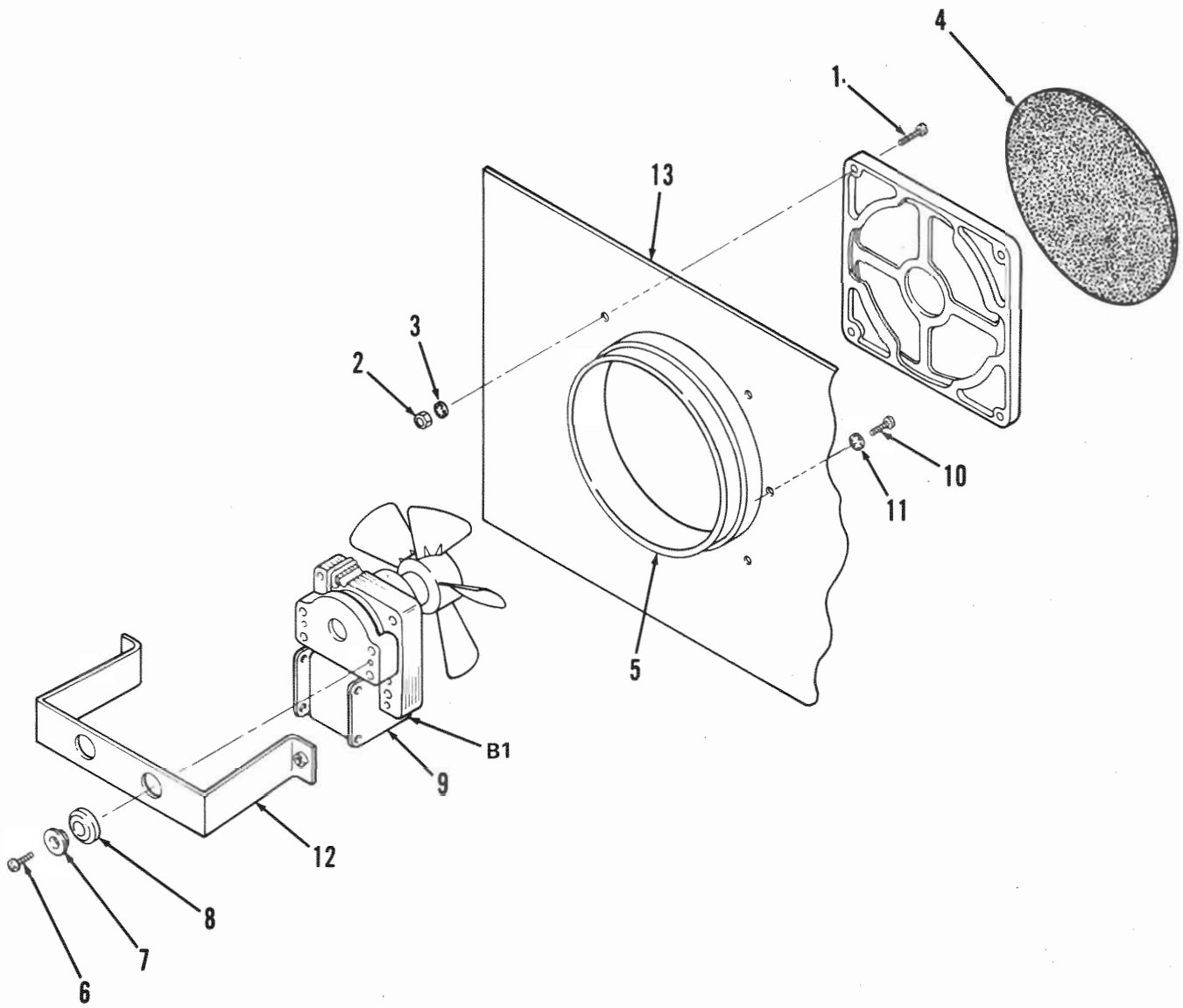

Fig. 6-2. Fan Panel Assembly



CROWN
M-600 AMPLIFIER

Parts List: Fan Panel Assembly

Index No.	Reference Designation	Description	Qty.	Crown Part No.	Other Information
1		Screw, binder head, phillips, No. 6-32 X 1/2	4	2176	
2		Nut, hexagon, No. 6-32	4	1889	
3		Lock washer, internal star, No. 6	4	1823	
4		Fan filter, 3-90-8106	1	3818	
5		Fan venturi	1	9535S	
6		Screw, oval head phillips, No. 10-32 X 1/2	2	3330	
7		Washer, motor mounting	2	1295	
8		Grommet, motor mounting	2	1605	
9	B 1	Fan and motor 3-90-8011	1	3817	
10		Screw, truss head phillips, No. 8-32 X 3/8	2	2155	
11		Lock washer, internal star, No. 8	2	1951	
12		Fan mounting bracket	1	41407	
13		Fan side cover	1	9518S	
		Foam tape	AR	2859	Mounted inside cover

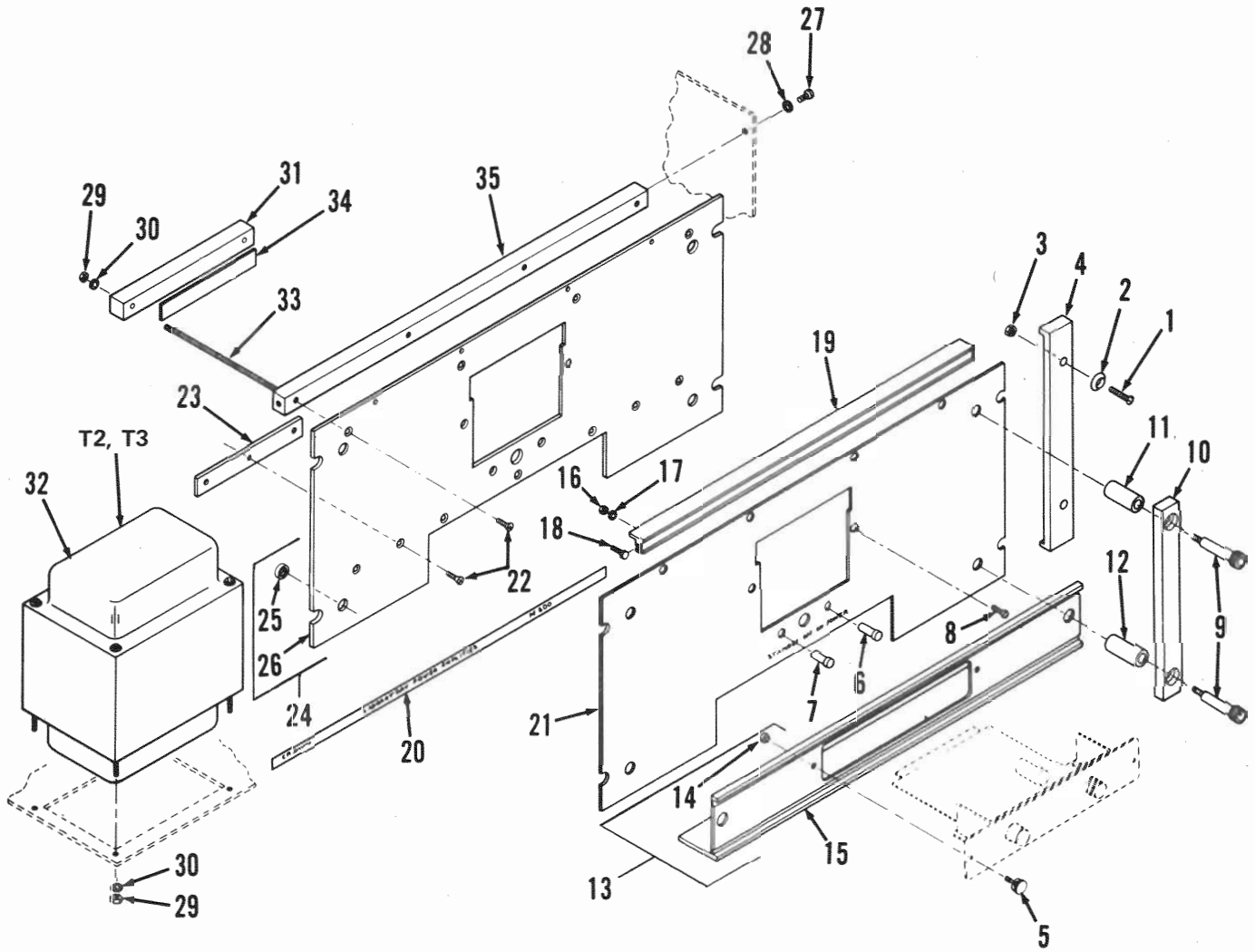

Fig. 6-3. Transformer and Front Panel Assembly



CROWN
M-600 AMPLIFIER

Parts List: Transformer and Front Panel Assembly

Index No.	Reference Designation	Description	Qty.	Crown Part No.	Other Information
1		Screw, oval pan head, No. 10-32 by 1 in. lg.	4	3488	
2		Washer, panel, nylon, No. 10	4	2119	
3		Nut, hexagon, No. 10-32	4	2170	
4		Bar, end	2	9520S	
5		Retainer, access door	2	2915	
6		Cap, lens, red	1	2359	Power on
7		Cap, lens, amber	1	2468	Standby
8		Screw, binding head, black, No. 6-32 by 3/8 in. lg.	2	2134	Retain meter module
9		Screw, cap, socket head, 5/16-18 by 1 in. lg.	4	3914	
10		Handle	2	9524S	
11		Spacer, handle, long	2	9525S	
12		Spacer, handle, short	2	9526S	
13		Extrusion Assembly, lower	1	41408	
14		· Nut, captive, No. 8-32	2	2018	
15		· Extrusion, lower	1	3869	
16		Nut, hexagon, No. 6-32	4	1889	
17		Washer, lock, internal tooth, No. 6	4	1823	
18		Screw, hexagon head, machine, No. 6-32 by 1/2 in. lg.	4	3917	
19		Extrusion, upper	1	3860	
20		Label, front panel	1	3915	
21		Overlay, front panel	1	9544R	
22		Screw, machine, flat head, No. 10-32 by 5/8 in. lg.	11	2825CAD	
23		Plate, retainer	2	9528S	
24		Panel assembly, front	1	41405	
25		· Nut, captive, 5/16-18	4	3858	
26		· Panel, front	1	9543S	
27		Screw, machine, truss head, No. 10-32 by 3/8 in. lg.	2	4013	
28		Washer, lock, internal tooth, No. 10	2	2279	
29		Nut, hexagon, No. 10-24	12	2829	
30		Washer, lock, internal tooth, No. 10	12	2279	
31		Bar, transformer clamp	2	9527S	
32	T2, T3	Transformer	2	4004	Earlier units used 3433.
33		Stud, transformer mounting	4	9549S	
34		Tape, foam	AR	2859	
35		Bracket, transformer mounting	1	9534S	

Table of Circuit Component Functions

Reference Designation	Circuit Function
C6	Filtering rectified output DM1.
C7	Filtering rectified output of DM1.
C8	Filtering rectified output of DM2.
C9	Filtering rectified output of DM2.
C10	Fan motor capacitor.
DM1	Rectifier in Vcc supply.
DM2	Rectifier in Vcc supply.

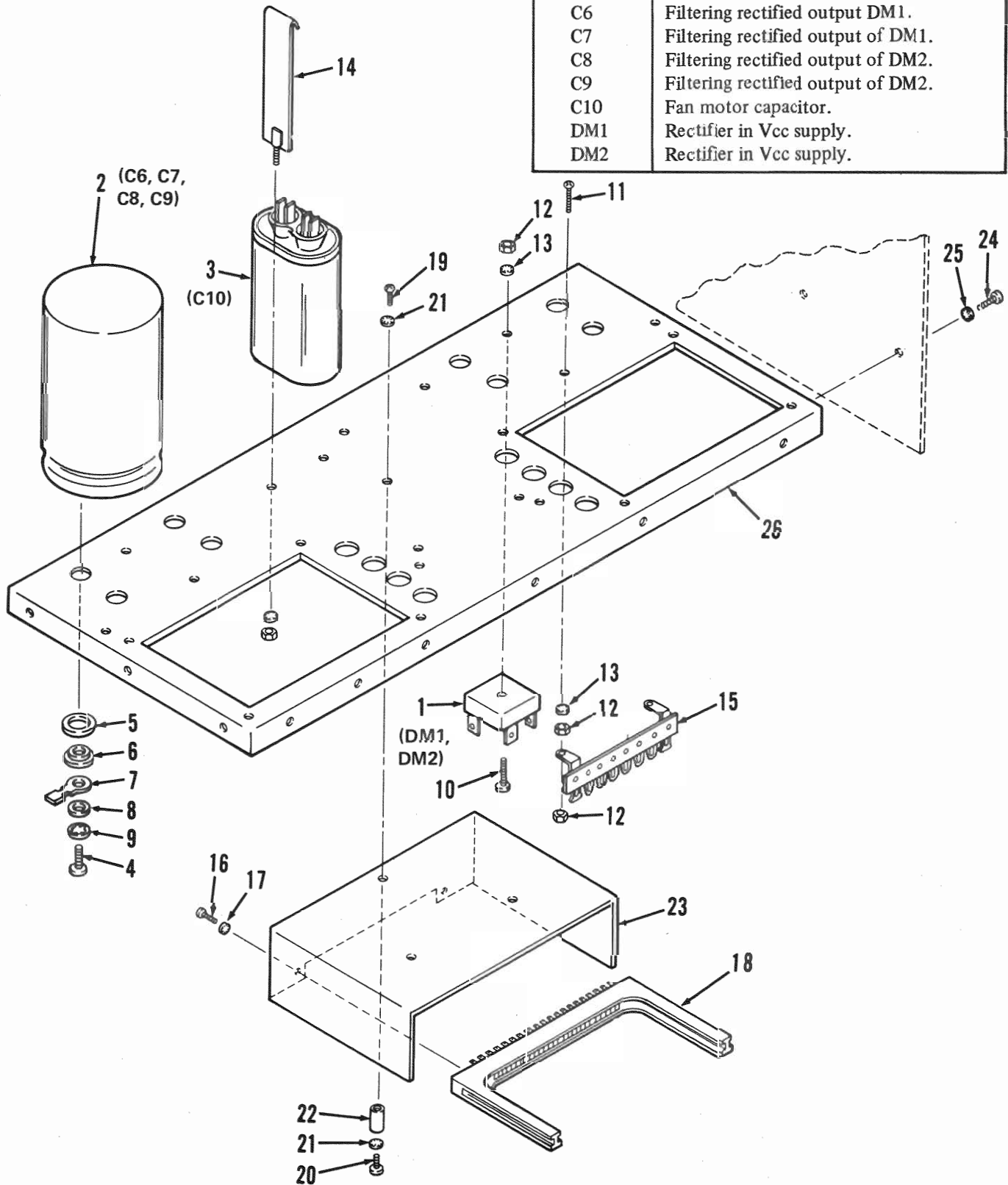

Fig. 6-4. Power Supply Assembly



CROWN
M-600 AMPLIFIER

Parts List: Power Supply Assembly

Index No.	Reference Designation	Description	Qty.	Crown Part No.	Other Information
		Bridges:			
1	DM1, DM2	SDA9903, 30A	2	3526	
		Capacitors:			
2	C6, C7, C8, C9	13,500 MF, 70V	4	3436	
3	C10	10MF, 236VAC, oil	1	3904	
		Miscellaneous:			
4		Screw, truss head phillips, No. 10-32 X 1/2	8	2049NIC	
5		Washer, nylon	8	1657	
6		Washer, shoulder, 5/16 fiber	8	3320	
7		Solder lug, 389, .218 hole	8	2934	
8		Washer, flat, No. 10	8	2101	
9		Lock washer, internal star, No. 10	8	2279	
10		Screw, binding head phillips, No. 6-32 X 3/4	2	2135	
11		Screw, binding head phillips, No. 6-32 X 1/2	4	2176	
12		Nut, hex, No. 6-32	8	1889	
13		Lock washer, internal star, No. 6	8	1823	
14		Bracket, capacitor mounting	1	20024S	
15		Terminal strip 8J6AJ	2	3503	
16		Screw, round head slotted, No. 4-40 X 3/8	2	1844	
17		Lock washer, internal star, No. 4	2	1824	
18		Socket, 22 pin printed circuit, Elco	1	3823	
19		Screw, binding head phillips, No. 6-32 X 1/4	3	1954	
20		Screw, binding head phillips No. 6-32 X 3/8	3	2134CAD	
21		Lock washer, internal star, No. 6	6	1823	
22		Switch mount spacer	3	1896	
23		Shield, plug-in module	1	9541S	
24		Screw, truss head phillips,	6	2049NIC	Nickel plated
25		Lock washer, internal star, No. 10	6	2279	
26		Mounting panel, transformer	1	9540S	

Table of Circuit Component Functions

Reference Designation	Circuit Function
C3	Output terminating capacitor.
C4	Part of decoupling network in ground side of output stage.
C11	
F1	Fan circuit fuse.
F2	Input power fuse.
J3M	Interlock jack.

Reference Designation	Circuit Function
L1	High-frequency stabilization of output terminals.
J3F	Interlock plug.
R1	Standard input protection.
R3	Output current sensing.
SW2	Delay switch.
SW3	Low-frequency protection switch.

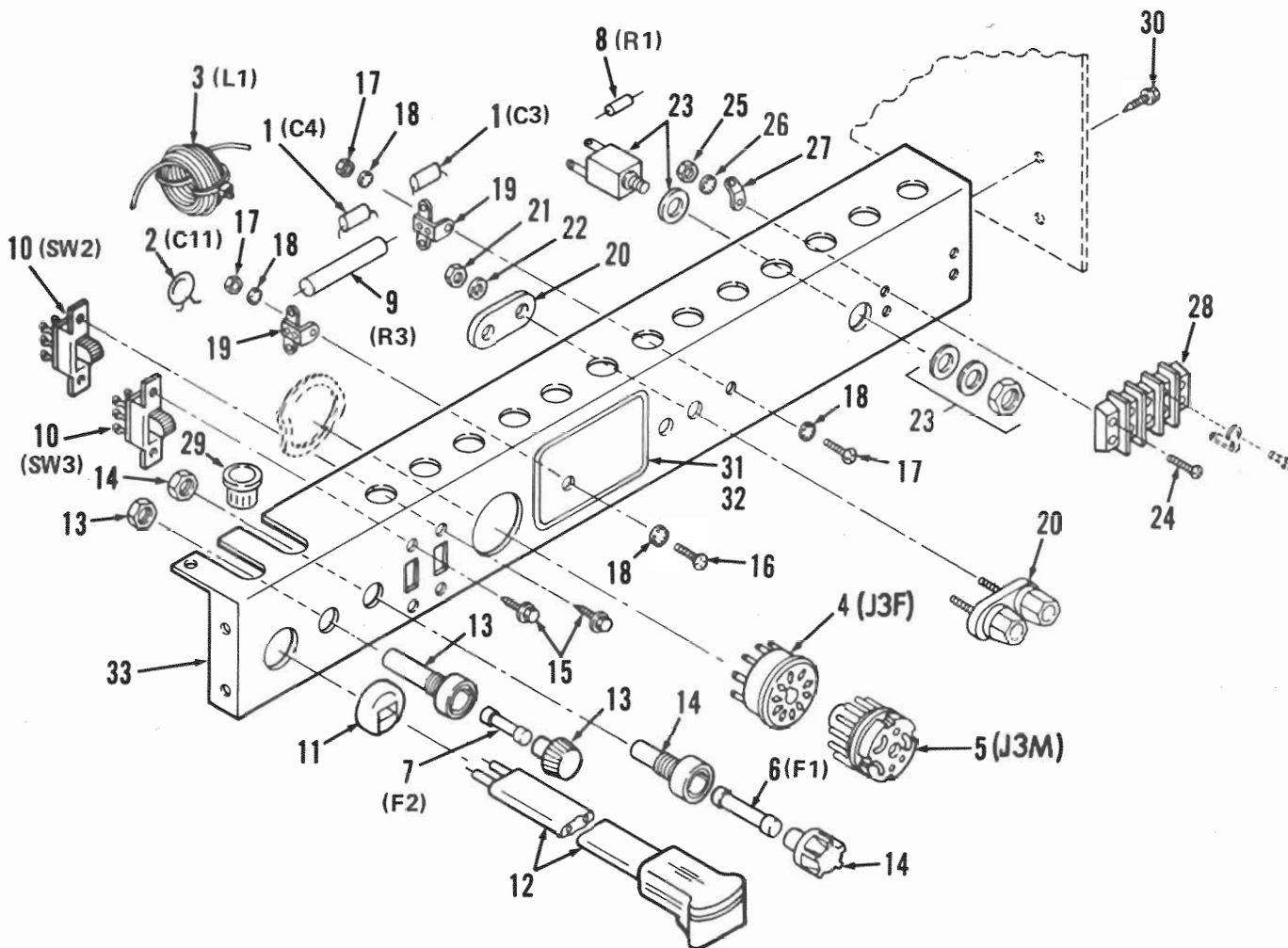

Fig. 6-5. Control Panel Assembly

Parts List: Control Panel Assembly

Index No.	Reference Designation	Description	Qty.	Crown Part No.	Other Information
Capacitors:					
1	C3, C4	.1MF, 200V filmatic	2	2938	
2	C11	.01MF, ceramic disc	1	1751	
Coils:					
3	L1	Coil, 2.5 microhenrys	1	9537	



CROWN M-600 AMPLIFIER

Parts List: Control Panel Assembly (Continued)

Index No.	Reference Designation	Description	Qty.	Crown Part No.	Other Information
Connectors:					
4	J3 F	Interlock jack	1	3910	
5	J3 M	Interlock plug	1	3911	
Fuses:					
6	F1	Fuse, AGC, .5 amp	1	3841	
7	F2	Fuse, 3AB, 20 amp	1	3840	
Resistors:					
8	R1	2.7 ohm, 1/2 watt, 10%	1	2857	
9	R3	2.7 ohm, 10 watt, 5%	1	3813	
Switches:					
10	SW2, SW3	Switch, slide, DPDT	2	2668	
Miscellaneous:					
11		Strain relief SR34-2	1	3815	
12		Power cord SPT-3, 3 conductor 12 gage	1	3877	
13		Fuseholder HTA	1	3256	
14		Fuseholder HKP	1	3839	
15		Screw, slotted hex head sheet metal, No. 8-18 X 3/8	4	3957	
16		Screw, binder head phillips, No. 6-32 X 1/4	2	1954	
17		Nut, hex, No. 6-32	2	1889	
18		Lock washer, internal star, No. 6	4	1823	
19		Terminal strip 2 ULD	2	3827	
20		Binding post, dual	1	2823	
21		Nut, hex, 3/8	1	1288NIC	Nickel plated
22		Washer, flat, 3/8	1	2189NIC	Nickel plated
23		Jack, 2 conductor, 112A-Hi-D	1	3423	
24		Screw, binder head phillips, No. 6-32 X 1/2	4	2176	
25		Nut, hex, No. 6-32	4	1889	
26		Lock washer, internal star, No. 6	3	1823	
27		Solder lug, 505, No. 6 hole	1	3163	
28		Barrier block, 3-140-Y	1	3842	
29		Snap bushing	4	3816	
30		Screw, slotted hex head sheet metal No. 8-18 X 3/8	4	3957	
31		Serial plate, M600	1	4193	
32		Serial plate, amplifier, less CSA	1	4191	
33		Control panel	1	9545S	
		Cable tie	4	1811	
		Black wire, No. 20	3	8626	Shorting leads in interlock plug

Table of Circuit Component Functions

Reference Designation	Circuit Function
R4	Part of stabilizing network in ground side of output stage.
R12	De-Qing of ground lead in output stage.
SW300	Senses temperature of output negative No. 3 module for speed control of fan.
SW301	Senses temperature of output negative No. 2 module for speed control of fan.

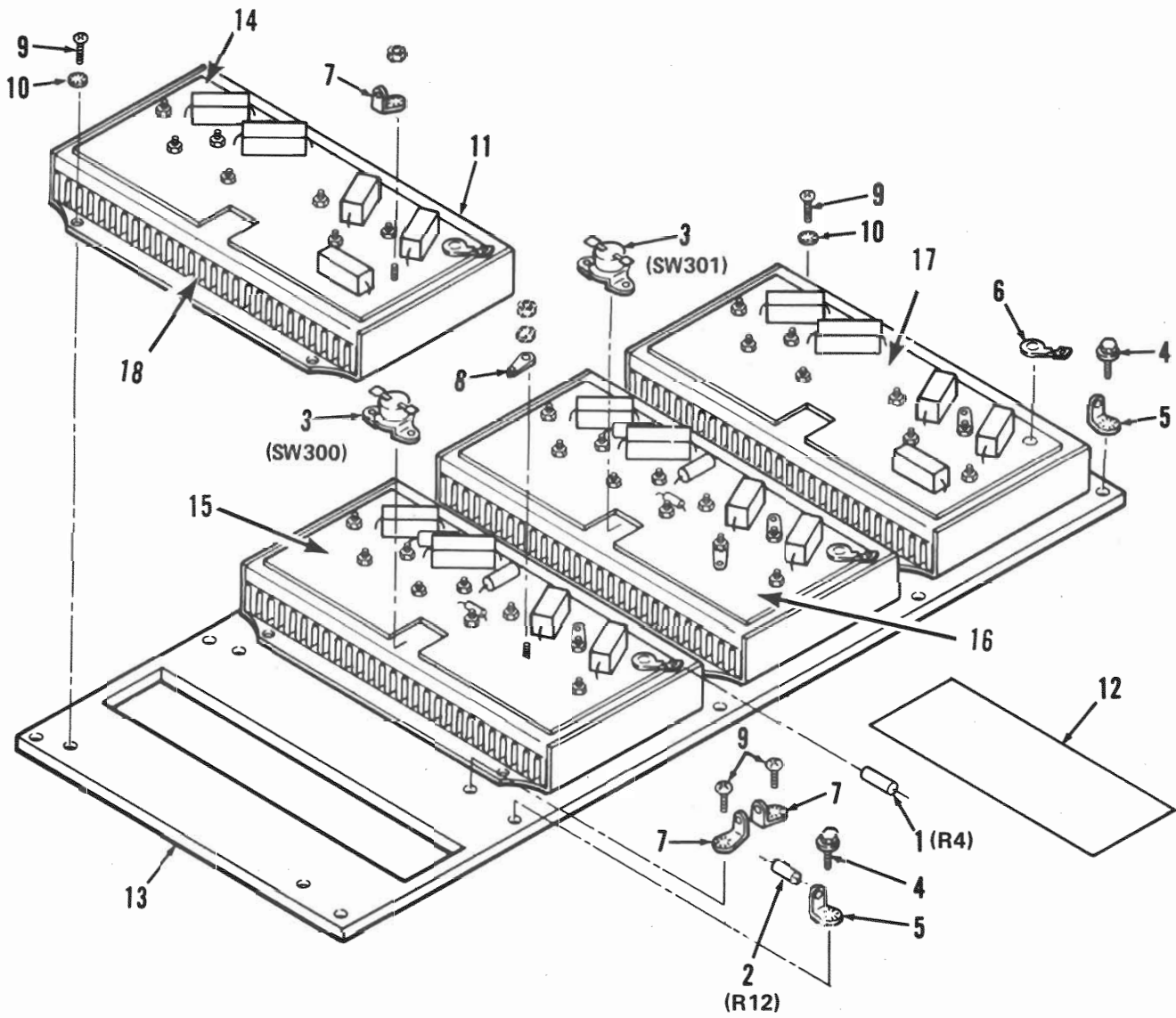

Fig. 6-6. Bottom Output Panel



CROWN
M-600 AMPLIFIER

Parts List: Bottom Output Panel

Index No.	Reference Designation	Description	Qty.	Crown Part No.	Other Information
Resistors:					
1	R4	2.7 ohm, 1 watt, 10%	1	1001	
2	R12	1 ohm, 1/2 watt, 10%	1	3612	
Thermal Switches:					
3	SW300 SW301	SPST, N.O., 140° F	2	3814	
Miscellaneous:					
4		Screw, Washer head, Sheet metal, No. 8 X 5/8	10	2757	Mounts output panel
5		Solder lug, 505, No. 8 hole	2	2935	
6		Solder lug, 389, .218 hole	4	2934	
7		Solder lug, 505, No. 6 hole	6	3163	
8		Solder lug, 11B, .144 hole	4	1220	
9		Screw, binding head, phillips, No. 6-32 X 1/4	16	1954	Mounts output
10		Washer, lock, internal star No. 6	12	1823	Mounts output assemblies
11		Output P.C. board and heatsink assembly	4		
12		Baffle, fishpaper 2 X 6 inches	1	3894	
13		Heatsink mounting plate	1	41406	Includes No. 6-32 plate nuts
14		Negative #1	1		
15		Negative #2	1		
16		Negative #3	1		
17		Negative #4	1		
18		9444 cool-pak well	4	3826	

Table of Circuit Component Functions

Reference Designation	Circuit Function
C2	Part of stabilizing network for positive output stages.
R2	Part of stabilizing network for output stages.
R5	De-Qing of positive output stage ground wire.
R11	De-Qing of positive output stage ground wire.

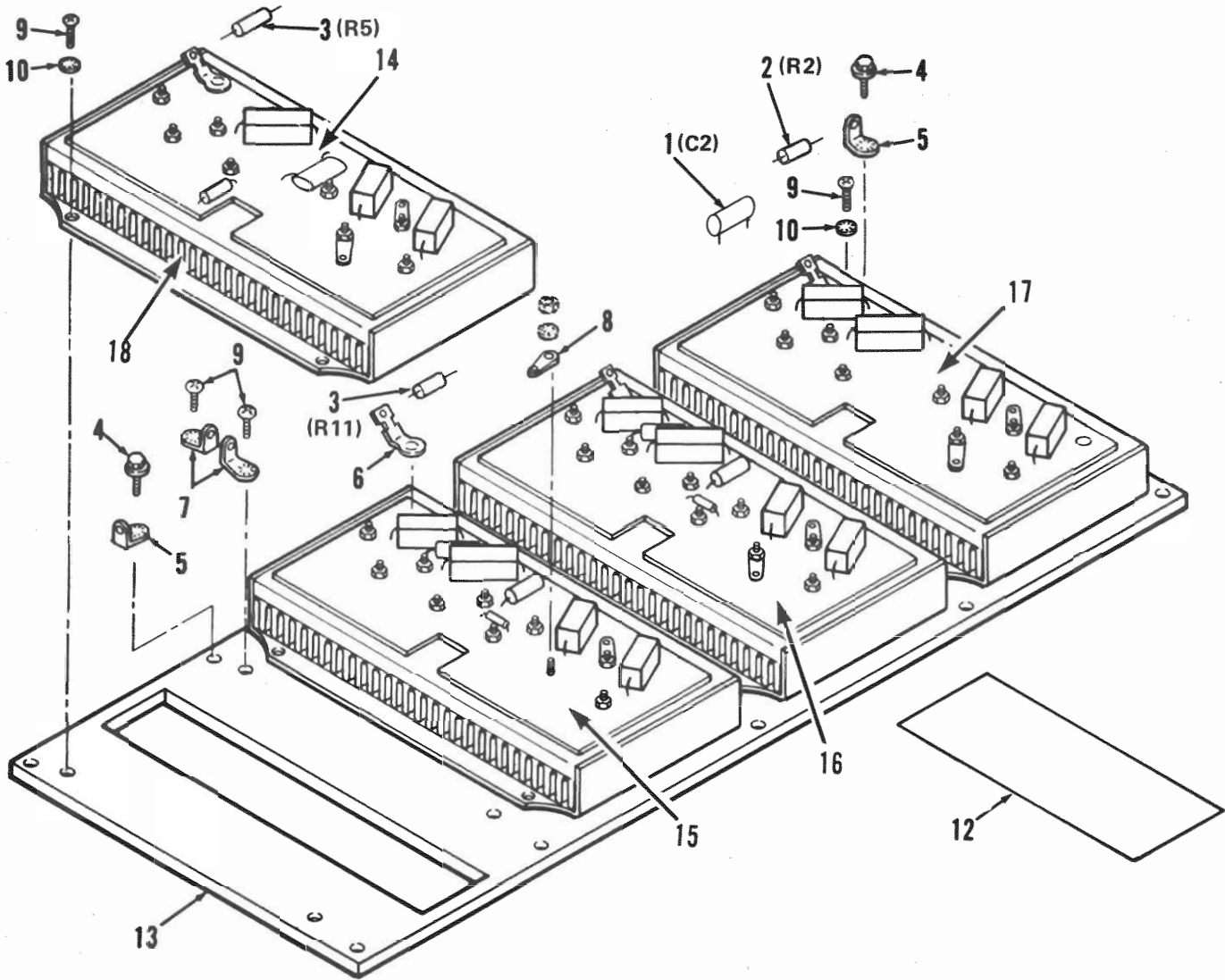

Fig. 6-7. Top Output Panel

CROWN
M-600 AMPLIFIER

Parts List: Top Output Panel

Index No.	Reference Designation	Description	Qty.	Crown Part No.	Other Information
		Capacitors:			
1	C2	.0047MF, 200V, poly	1	3996	
		Resistors:			
2	R2	5.6 ohm, 1/2 watt, 5%	1	3299	
3	R5	1 ohm, 1/2 watt, 10%	2	3612	
	R11				
		Miscellaneous:			
4		Screw, washer head, sheet metal, No. 8 X 5/8	10	2757	Mounts output panel
5		Solder lug, 505, No. 8 hole	3	2935	
6		Solder lug, 389, .218 hole	4	2934	
7		Solder lug, 505, No. 6 hole	6	3163	
8		Solder lug, 11B, .144 hole	4	1220	
9		Screw, binder head, phillips, No. 6-32 X 1/4	16	1954	Mounts output assemblies
10		Washer, lock, internal star, No. 6	10	1823	Mounts output assemblies
11		Output P.C. Board and heatsink assembly	4		
12		Baffle, fishpaper, 2 X 6 inches	1	3894	
13		Heatsink mounting plate	1	41406	Includes No. 6-32 Plate nuts
14		Positive #1	1		
15		Positive #2	1		
16		Positive #3	1		
17		Positive #4	1		
18		9444 cool-pak well	4	3826	

Table of Circuit Component Functions

Reference Designation	Circuit Function
K1	Switches Amplifier to standby mode.
R10	De-Qing of input ground lead.

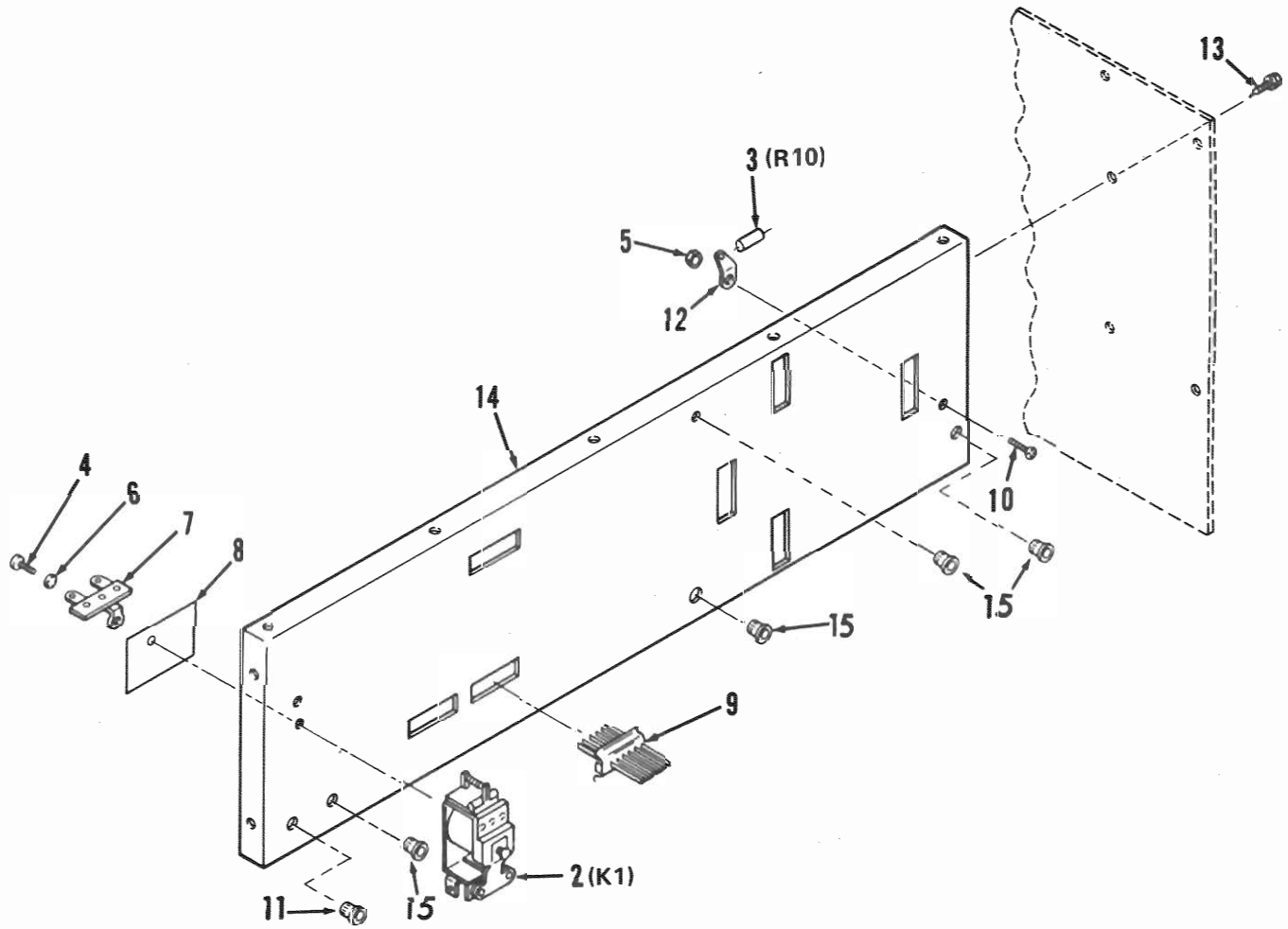

Fig. 6-8. Duct Back Panel Assembly



CROWN
M-600 AMPLIFIER

Parts List: Duct Back Panel Assembly

Index No.	Reference Designation	Description	Qty.	Crown Part No.	Other Information
		Capacitors:			
1	C1	.01MF ceramic disc	1	1751	
		Relays:			
2	K1	Relay, W88KDX-3, 24 volt	1	3868	
		Resistors:			
3	R10	2.7 ohm, 1/2 watt, 10%	1	2857	
		Miscellaneous:			
4		Screw, binder head phillips, No. 6-32 X 1/2	1	2176	
5		Nut, hex, No. 6-32	1	1889	
6		Lock washer, internal star, No. 6	1	1823	
7		Terminal strip, 3AUA, No. 6 hole	1	1242	
8		Insulator, 1-G-2	1	3599	
9		Ampmod 1, PC chassis, 7 pin	7	3851	
10		Screw, binder head phillips, No. 6-32 X 1/4	1	1954	
11		Bushing, snap-in, .500-6	1	3816	
12		Solder lug, 505, No. 6 hole	1	3163	
13		Screw, slotted hex head sheet metal, No. 8-18 X 3/8	4	3957	
14		Back duct panel	1	9521S	
15		Bushing, snap-in .375-4	4	2412	

Table of Circuit Component Functions

Reference Designation	Circuit Function
I1	Standby indicator light.
I2	Power on indicator light.
R6	Voltage dropping resistor for I2.
R7	Voltage dropping resistor for I1.
R8	Voltage dropping resistor for fan motor low speed.
R9	Voltage dropping resistor for fan motor high speed.
SW1	Power control switch.
T1	Low voltage power supply transformer.

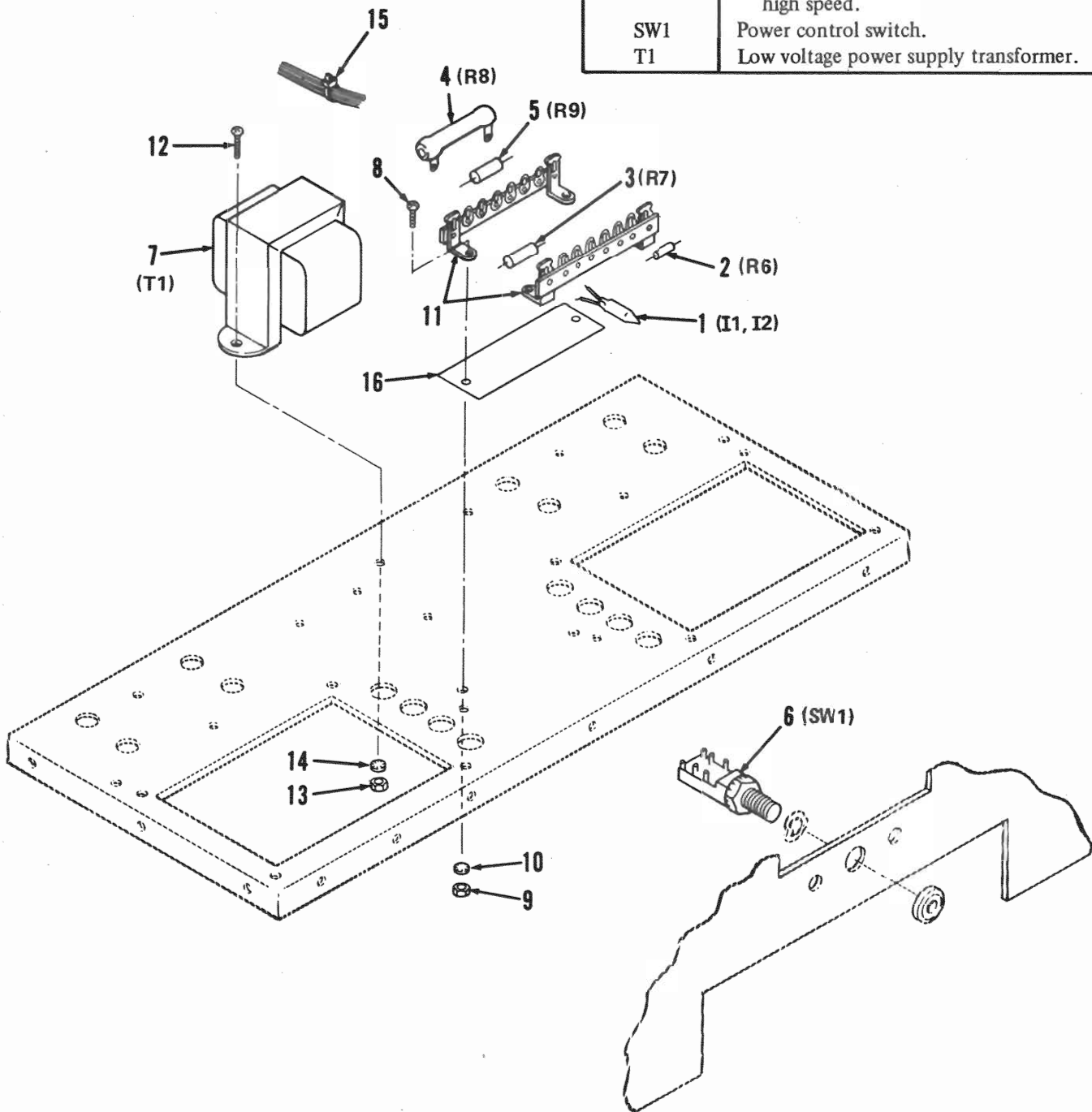

Fig. 6-9. Harness Assembly



CROWN
M-600 AMPLIFIER

Parts List: Harness Assembly

Index No.	Reference Designation	Description	Qty.	Crown Part No.	Other Information
		Lamps:			
1	I1, I2	Neon, NE2H	2	2500	
		Resistors:			
2	R6	27K ohm, 1/2 watt, 10%	1	1056	
3	R7	100K ohm, 1 watt, 10%	1	3809	
4	R8	600 ohm, 12 watt, 5% wire wound	1	3902	
5	R9	2.7 ohm, 1 watt, 10%	1	1001	
		Switches:			
6	SW1	Power, DPDT Pushbutton, NE15	1	3822	
		Transformers:			
7	T1	46P28B	1	3819	
		Miscellaneous:			
8		Screw, binder head phillips, No. 6-32 X 1/2	2	2176	
9		Nut, hex, No. 6-32	2	1889	
10		Washer, lock, internal star, No. 6	2	1823	
11		Terminal strip, 8J6AJ	2	3503	
12		Screw, truss head phillips No. 8-32 X 3/8	2	2155	
13		Nut, hex, No. 8-32	2	1986	
14		Washer, lock, internal star No. 8	2	1951	
15		Cable tie	57	1811	
16		Insulator, G-6-G	1	3600	

Table of Circuit Component Functions

Reference Designation	Circuit Function
I200	db below maximum indicator.
I201	db below red indicator light.
I203	Meter illumination.
I204	Meter illumination.
IC200	Comparator for controlling I200 and I201.
IC201	Operational amplifiers.
IC202	Operational amplifiers.

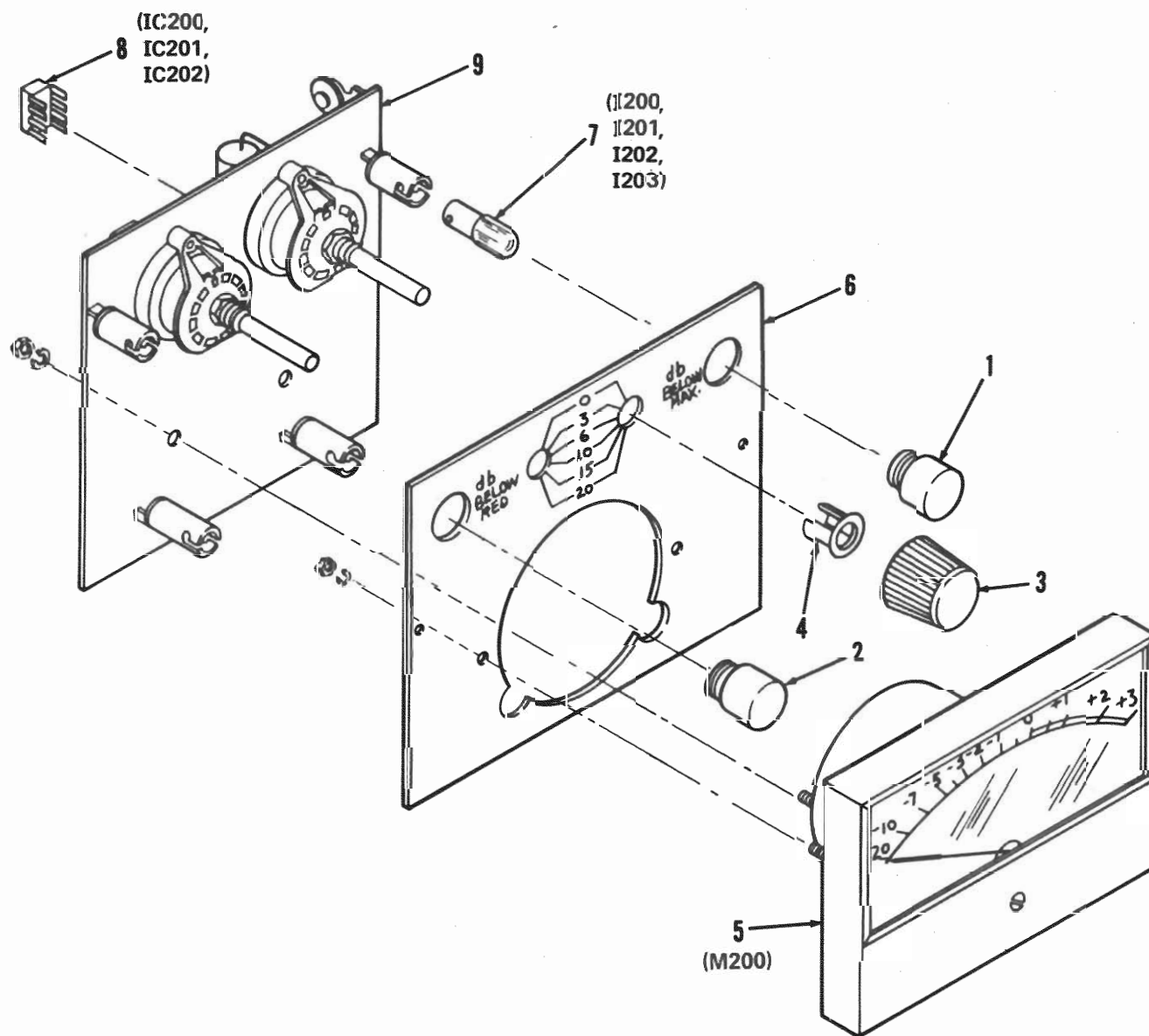

Fig. 6-10. Meter Module



CROWN
M-600 AMPLIFIER

Parts List: Meter Module

Index No.	Reference Designation	Description	Qty.	Crown Part No.	Other Information
1		Lens, red	1	3844	Screw-in type
2		Lens, green	1	3845	Screw-in type
3		Knob	2	3513	Setscrew type
4		Bushing	2	2412	Snap-in type
5	M200	Meter	1	3812	Mounting parts included
6		Panel, front, meter plate	1	9533R	
7	I200, I201, I202, I203	Lamp, 1866	4	2899	6.3 volt, .25 amp.
8	IC200 A&B IC201 A&B IC202 A&B	Integrated Circuit, Dual Operational amplifier	3	3919	Type RC4558 dual
9		Display Module	1	41376ML	

Table of Circuit Component Functions

Reference Designation	Circuit Function
C500	Input dc blocking capacitor.
R500	Attenuation control.
SW500	Switches C500 into or out of input circuit.

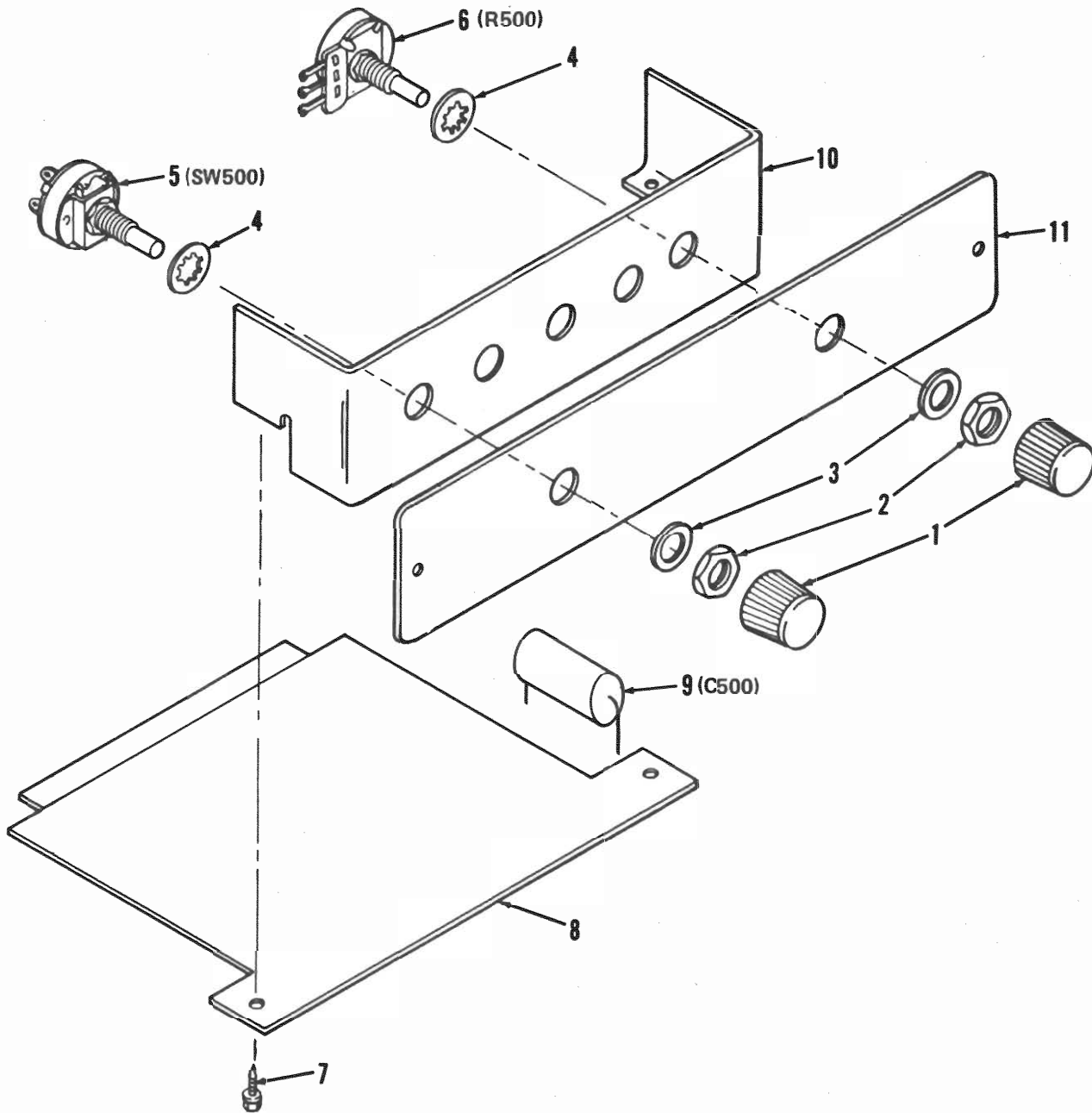

Fig. 6-11. Input Control Panel



CROWN
M-600 AMPLIFIER

Parts List: Input Control Panel

Index No.	Reference Designation	Description	Qty.	Crown Part No.	Other Information
1		Knob	2	3513	Setscrew type
2		Nut, hexagon	1	1288NIC	Nickel plated
3		Washer, flat	2	2189NIC	Nickel plated
4		Washer, lock	2	2188	
5	SW500	Switch, rotary	1	3492	Two position coupling switch
6	R500	Resistor, variable 25K ohms	1	2942	Attenuation Pot.
7		Screw, self tapping, No. 8-18 by 3/8 in. lg	2	3957	
8		Plug-in board, standard	1	7931	
9	C500	1.0 MF, 100V, filmatic		3008	
10		Bracket, front end	1	9530S	
11		Door, access	1	9529R	
12		Tie, cable	3	1811	

Table of Circuit Component Functions

Reference Designation	Circuit Function	Reference Designation	Circuit Function	Reference Designation	Circuit Function	Reference Designation	Circuit Function
C100	+15 volt supply bypass.	D102	Limiter isolation diode in protection circuit.	Q120	Negative output predriver.	R138	Limiter current signal to base of Q108.
C101	Stabilizing IC100A.	D103	Reference diode in protection circuit.	R100	Adjusting input offset.	R139	Voltage memory signal to base of Q108.
C102	Stabilizing IC100A.	D104	Reference diode in protection circuit.	R101	Isolating IC100A (+) input from input offset.	R140	Setting level for protection circuit.
C103	Stabilizing IC100A.	D105	Reference diode in protection circuit.	R102	Biasing base of Q100.	R141	Setting levels for protection circuit.
C104	Stabilizing IC100A.	D106	Reference diode in protection circuit.	R103	Biasing base of Q100.	R142	Setting levels for protection circuit.
C105	Controlling IC100A input rolloff.	D107	Rectifier diode in protection circuit.	R104	Biasing base of Q100.	R143	Setting levels for protection circuit.
C106	Main feedback loop.	D108	Rectifier diode in protection circuit.	R105	Isolating input to IC100A (+).	R144	Setting levels for protection circuit.
C107	Stabilizing IC100B.	D109	Limiter isolation diode in protection circuit.	R106	Setting base bias for Q101.	R145	Setting levels for protection circuit.
C108	Bypassing R127 in feedback to IC100B (+) input.	D110	Rectifying diode in +VBB power supply.	R107	Setting emitter bias for Q101.	R146	Setting levels for protection circuit.
C109	Phase lead compensation.	D111	Rectifier diode in protection circuit.	R108	Setting base bias for Q104.	R147	Desensitizing base of Q111.
C110	Phase lead compensation.	D112	Rectifier diode in protection circuit.	R109	Controlling feedback to IC100A around Q101.	R148	Part of decoupling network for Q109.
C111	Pole cancellation in last voltage amplifier.	D113	Limiter isolation diode in protection circuit.	R110	Setting base bias for Q104.	R149	Biasing emitter of Q109.
C112	Inner feedback loop.	D114	Limiter isolation diode in protection circuit.	R111	Setting base bias for Q105.	R150	Biasing base of Q109.
C113	Pole cancellation in last voltage amplifier.	D115	Rectifying diode in -VBB power supply.	R112	Controlling feedback to IC100A.	R151	Isolating base of Q109 from IC100B output.
C114	Negative limitation stabilization.	IC100	Main input operational amplifier and bridge balance operational amplifier.	R113	Controlling feedback to IC100A.	R152	Isolating base of Q110 from IC100B output.
C115	Phase lead compensation.	L100	Stabilizing output stage driven by Q117.	R114	Isolating IC100A (-) input from output offset.	R153	Biasing base of Q110.
C116	Phase lead compensation.	Q100	Temperature compensation.	R115	Adjusting output offset to IC100A.	R154	Biasing emitter of Q110.
C117	Phase lead compensation.	Q101	Paralleling output of IC100A to improve response of IC100A.	R116	Setting base bias for Q105.	R155	Limiter current signal to base of Q111.
C118	Negative ground side of bridge limiter stabilization.	Q102	Current limiting in last voltage amplifier circuit.	R117	Setting static balance for IC100B.	R156	Desensitizing base of Q112.
C119	Protection circuit memory.	Q103	Last voltage amplifier (positive).	R118	Stabilizing IC100B.	R157	Limiting current in base of Q112.
C120	Protection circuit memory.	Q104	Positive signal translator.	R119	Isolating input of IC100B from static balance.	R158	Voltage memory signal to base of Q113.
C121	Positive groundside of bridge limiter stabilization.	Q105	Negative signal translator.	R120	Reference signal to IC100B (-) input.	R159	Stabilizing Q113.
C122	Controls limiter high frequency voltage dependence.	Q106	Last voltage amplifier (negative).	R121	Limiting dynamic balance adjustment range.	R160	Limiter current signal to base of Q113.
C123	Stabilizing protection circuit.	Q107	Current limiting in last voltage amplifier circuit.	R122	Adjusting dynamic balance.	R161	Setting bias for base of Q114.
C124	Protection circuit memory.	Q108	Negative limiter in protection circuit.	R123	Limiting dynamic balance to adjustment range.	R162	Setting base bias for Q300.
C125	Protection circuit memory.	Q109	Buffer to isolate output of IC100B from output stages.	R124	Attenuating (-) input of IC100B.	R163	Setting bias for Q300.
C126	Positive limiter stabilization.	Q110	Buffer to isolate output of IC100B from output stages.	R125	Attenuating (+) input of IC100B.	R164	Setting bias for Q300.
C127	Stabilization and slew rate control.	Q111	Negative limiter in protection circuit.	R126	Stabilizing IC100B.	R165	Feedback to base of Q300.
C128	Filtering in power supply.	Q112	Positive limiter in protection circuit.	R127	Bridge balance feedback to IC100B (+) input.	R166	Biasing emitter of Q117.
C129	Phase lead compensation in emitter of Q117.	Q113	Positive limiter in protection circuit.	R128	Biasing base of Q103.	R167	Biasing base of Q319.
C120	Stabilization and slew rate control.	Q114	Bias servo amplifier.	R129	Biasing emitter of Q103.	R168	Biasing base of Q319.
C131	Stabilization and slew rate control.	Q115	Positive output predriver.	R130	Biasing emitter of Q104.	R169	Biasing base of Q319.
C132	Filtering in power supply.	Q116	Provides rapid discharge of base of Q301.	R131	Stabilizing for Q104 and Q105.	R170	Biasing emitter of Q120.
C133	Stabilization and slew rate control.	Q117	Negative output predriver.	R132	Referencing Q104 and Q105 to ground.	R171	Setting IC100A inputs to (-) unity gain.
C134	Controlling slew rate in last voltage amplifier.	Q118	Positive output predriver.	R133	Inner feedback loop.	R172	Phase load network in emitter of Q117.
C135	Inner feedback loop.	Q119	Provides rapid discharge of base of Q320.	R134	Biasing emitter of Q105.	R173	Voltage memory signal to base of Q111.
D100	Protect IC100A against high input signal.			R135	Biasing base of Q106.	R174	Voltage memory signal to base of Q111.
D101	Protect IC100A against high input signal.			R136	Biasing emitter of Q106.	R175	Collector load of Q100.

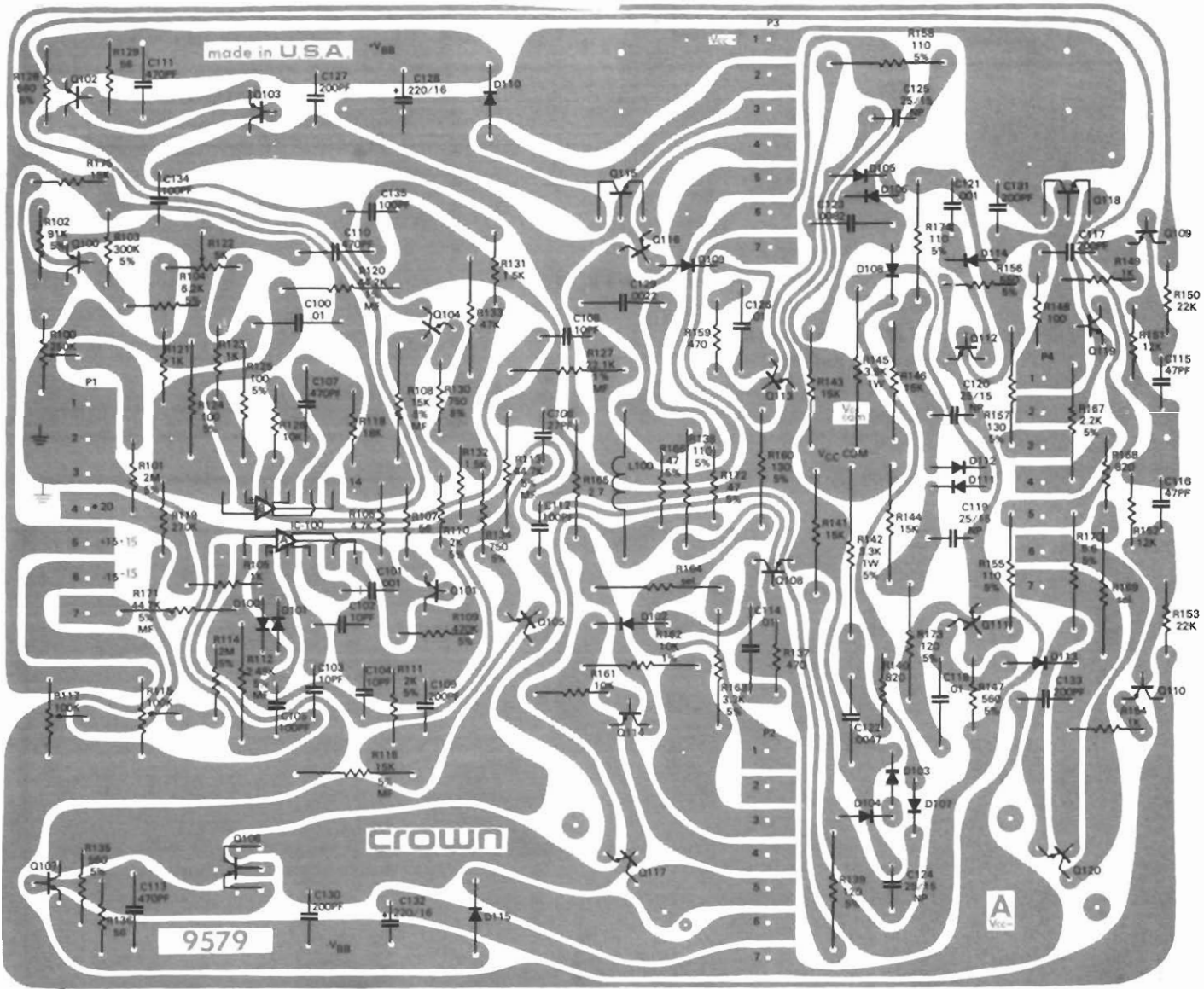

Fig. 6-12. Main Module Printed Circuit Card

Index No.	Reference Designation	Description	Qty.	Crown Part No.	Other Information
	R170	5.6 ohm, 1/2 watt, 5%	1	3299	
	R175	15K ohm, 1/4 watt, 10%	1	2632	
	Transistors:				
	Q100, Q107, Q109, Q112, Q113, Q114	2N3859A (selected)	6	2961	
	Q101, Q102, Q108, Q110, Q111, Q116, Q119	2N4125	7	3625	
	Q103, Q117, Q120	2N4929 SS7304 (selected)	3	2923	
	Q104	MPSA43	1	3810	
	Q105	MPSA93	1	3578	
	Q106, Q115, Q118	NSD128	3	4061	
	Miscellaneous:				
		IC socket, 14 pin DIL	1	3450	
		Cooler, TO-5	1	3175	Mounts on Q103
		Mounting Pad, TO-5	1	1250	Used to mount Q103
		Heatsink, PA1-1U, TO-5P	2	3820	Mounts on Q117 and Q120
		Screw, round head, No. 2-56X1/2	4	2071	Mounts 3820 heatsink
		Nut, hex No. 2-56	4	1817	Mounts 3820 heatsink
		Lockwasher, internal star, No. 2	4	3912	Mounts 3820 heatsink
		Heatsink, LP5A1U, TO-5M	2	3821	Mounts on Q115 and Q118
		Nut, hex, No. 4-40	4	1938	Mounts 3821 heatsink
		Lockwasher, internal star, No. 4	4	1824	Mounts 3821 heatsink
		Receptacle, PC	4	3519	
		Ampmod 3 PC receptacle HI-P	28	3846	
		Screw, round head, No. 4-40 X 1/2	4	1925	

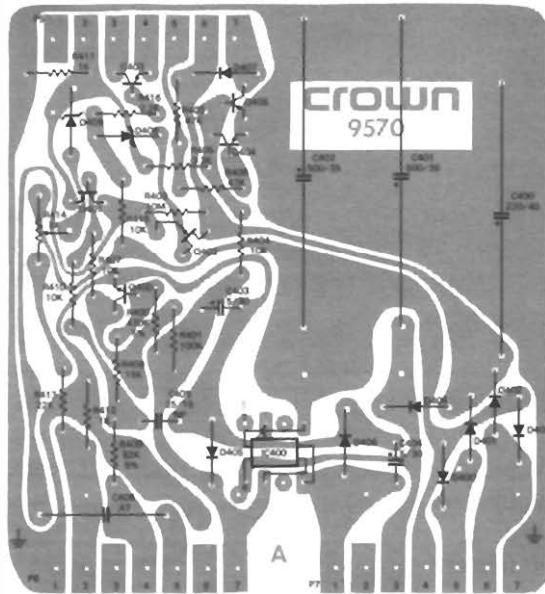

Fig. 6-13. Power Control Module Printed Circuit Card

Parts List: Power Control Module Printed Circuit Card

Index No.	Reference Designation	Description	Qty.	Crown Part No.	Other Information
		Power Supply Module	1	41480	
		Capacitors:			
	C400	220MF, 40V axial	1	4147	
	C401, C402	500MF, 35V	2	3913	
	C403, C404	5MF, 30V vertical	2	4026	
	C405	25MF, 15V NP vertical	1	3186	
	C406	.47MF, 100V poly	1	3995	

Parts List: Main Module Printed Circuit Card

Index No.	Reference Designation	Description	Qty.	Crown Part No.	Other Information
		Main Module	1	41483	
		Capacitors:			
	C100, C114, C118, C126	.01 MF, ceramic disc	4	1751	
	C101, C121	.001 MF, ceramic disc	2	2288	
	C102, C103, C104, C108	10 PF, mica	4	2821	
	C105, C112, C134, C135	100 PF, mica	4	3410	
	C106	27 PF, mica	1	2342	
	C107, C110, C111, C113	470 PF, mica	4	2511	
	C109, C117, C127, C130, C131, C133	200 PF, mica	6	3411	
	C115, C116	47 PF, mica	2	3409	
	C119, C120, C124, C125	25 MF, 15V, NP vertical	4	3186	
	C122	.0047 MF, 200V, poly	1	3996	
	C123	.0082 MF, 200V, filmatic	1	3063	
	C128, C132	200 MF, 16V, vertical	2	3796	
	C129	.0022 MF, 200V, filmatic	1	3285	
		Coil:			
	L100	1 mhy axial lead	1	2441	
		Diodes:			
	D100, D101, D103, D104, D105, D106, D107, D108, D109, D111, D112, D114	1N4148	12	3181	
	D102, D113	1N270	2	3447	
	D110, D115	1N4003	2	2851	
		Integrated Circuit:			
	IC-100A, B	uA739 dual op-amp	1	3231	
		Resistors:			
	R100	250K ohm, vertical pot	1	3028	Input Offset
	R101, R114	2M ohm, 1/4 watt, 5%	2	3199	
	R102	91K ohm, 1/4 watt, 5%	1	3621	
	R103	300K ohm, 1/4 watt, 5%	1	4221	



CROWN

M-600 AMPLIFIER

Index No.	Reference Designation	Description	Qty.	Crown Part No.	Other Information
	R104	6.2K ohm, 1/4 watt, 5%	1	3619	
	R105, R121, R123, R149, R154	1K ohm, 1/4 watt, 10%	5	2627	
	R106	4.7K ohm, 1/4 watt, 10%	1	3939	
	R107, R129, R136	56 ohm, 1/4 watt, 10%	3	3511	
	R108, R116	15K ohm, 1/2 watt, 5% film	2	3133	
	R109	470K ohm, 1/4 watt, 5%	1	4225	
	R110, R111	2K ohm, 1/4 watt, 5%	2	3804	
	R112	2.49K ohm, 1/2 watt, 5%, film	1	3853	
	R113, R171	44.7K ohm, 1/2 watt, 5%, film	2	3854	
	R115, R117	100K ohm, vertical pot	2	1713	R115—Output Offset
	R118	18K ohm, 1/4 watt, 10%	1	2633	R117—Static Balance
	R119	270K ohm, 1/4 watt, 10%	1	2885	
	R120	44.2K ohm, 1/2 watt, 1%, film	1	3128	
	R122	5K ohm, vertical pot	1	1681	Dynamic Balance
	R124, R125	100 ohm, 1/2 watt, 5%, film	2	2350	
	R126, R161	10K ohm, 1/4 watt, 10%	2	2631	
	R127	22.1K ohm, 1/2 watt, 1%, film	1	3855	
	R128, R135, R147, R156	560 ohm, 1/4 watt, 5%	4	3802	
	R130, R134	750 ohm, 1/4 watt, 5%	2	3803	
	R131, R132	1.5K ohm, 1/4 watt, 10%	2	2876	
	R133	47K ohm, 1/2 watt, 10%	1	1058	
	R137, R159	470 ohm, 1/4 watt, 10%	2	2626	
	R138, R155, R158, R174	110 ohm, 1/2 watt, 5% film	4	3836	
	R139, R173	120 ohm, 1/2 watt, 5% film	2	3837	
	R140, R168	820 ohm, 1/4 watt, 10%	2	3301	
	R141, R143, R144, R146	15K ohm, 1/2 watt, 10%	4	1064	
	R142	3.3K ohm, 1 watt, 5%	1	3617	
	R145	3.9K ohm, 1 watt, 10%	1	3618	
	R148	100 ohm, 1/4 watt, 10%	1	2872	
	R150, R153	22K ohm, 1/4 watt, 10%	2	3302	
	R151, R152	12K ohm, 1/4 watt, 10%	2	2878	
	R157, R160	130 ohm, 1/2 watt, 5% film	2	3903	
	R162	10K ohm, 1/2 watt, 1% film	1	2343	
	R163	3.3K ohm, 1/2 watt, 5% film	1	3146	
	R164, R169	selected value	2		
	R165	2.7 ohm, 1/2 watt, 10%	1	2857	
	R166, R172	47 ohm, 1/4 watt, 5%	2	1011	
	R167	2.2K ohm, 1/2 watt, 5% film	1	3145	

Index No.	Reference Designation	Description	Qty.	Crown Part No.	Other Information
	R170	5.6 ohm, 1/2 watt, 5%	1	3299	
	R175	15K ohm, 1/4 watt, 10%	1	2632	
	Transistors:				
	Q100, Q107, Q109, Q112, Q113, Q114	2N3859A (selected)	6	2961	
	Q101, Q102, Q108, Q110, Q111, Q116, Q119	2N4125	7	3625	
	Q103, Q117, Q120	2N4929 SS7304 (selected)	3	2923	
	Q104	MPSA43	1	3810	
	Q105	MPSA93	1	3578	
	Q106, Q115, Q118	NSD128	3	4061	
	Miscellaneous:				
		IC socket, 14 pin DIL	1	3450	
		Cooler, TO-5	1	3175	Mounts on Q103
		Mounting Pad, TO-5	1	1250	Used to mount Q103
		Heatsink, PA1-1U, TO-5P	2	3820	Mounts on Q117 and Q120
		Screw, round head, No. 2-56X1/2	4	2071	Mounts 3820 heatsink
		Nut, hex No. 2-56	4	1817	Mounts 3820 heatsink
		Lockwasher, internal star, No. 2	4	3912	Mounts 3820 heatsink
		Heatsink, LP5A1U, TO-5M	2	3821	Mounts on Q115 and Q118
		Nut, hex, No. 4-40	4	1938	Mounts 3821 heatsink
		Lockwasher, internal star, No. 4	4	1824	Mounts 3821 heatsink
		Receptacle, PC	4	3519	
		Ampmod 3 PC receptacle HI-P	28	3846	
		Screw, round head, No. 4-40 X 1/2	4	1925	



CROWN M-600 AMPLIFIER

Parts List: Power Control Module Printed Circuit Card (Continued)

Index No.	Reference Designation	Description	Qty.	Crown Part No.	Other Information
		Integrated Circuits:			
	IC400	RC41950N dual regulator	1	3825	
		Diodes:			
	D400, D401, D402, D403, D404, D405, D406	1N4003	7	2851	
	D407	1N4148	1	3181	
	D408	1N966B 16V zener	1	3533	
	D409	1N970B 24V zener	1	3824	
		Resistors:			
	R400	470K ohm, 1/4 watt, 5%	1	4225	
	R401	100K ohm, 1/4 watt, 10%	1	2883	
	R402	10M ohm, 1/4 watt, 10%	1	3221	
	R403, R406	47K ohm, 1/4 watt, 10%	2	2880	
	R404, R407, R410, R415	10K ohm, 1/4 watt, 10%	4	2631	
	R405	3.3K ohm, 1/4 watt, 10%	1	2629	
	R408	15K ohm, 1/4 watt, 10%	1	2632	
	R409	82K ohm, 1/4 watt, 5%	1	4212	
	R411, R412	1K ohm, 1/4 watt, 10%	2	2627	
	R413	22K ohm, 1/4 watt, 10%	1	3302	
	R414	5K ohm, vertical pot	1	1681	Over-Voltage Adjust
	R416	2.2K ohm, 1/4 watt, 10%	1	2628	
		Transistors:			
	Q400, Q401, Q403, Q404 Q405	2N3859A (selected)	5	2961	
	Q402	2N5459 N-CH JFET	1	3053	
		Miscellaneous:			
		IC cooler	1	9532	
		IC socket, 8 pin DIL	1	3451	
		Ampmod 3 PC receptacle HI-P	21	3846	
		Transistor socket, MPT3003	1	3920	

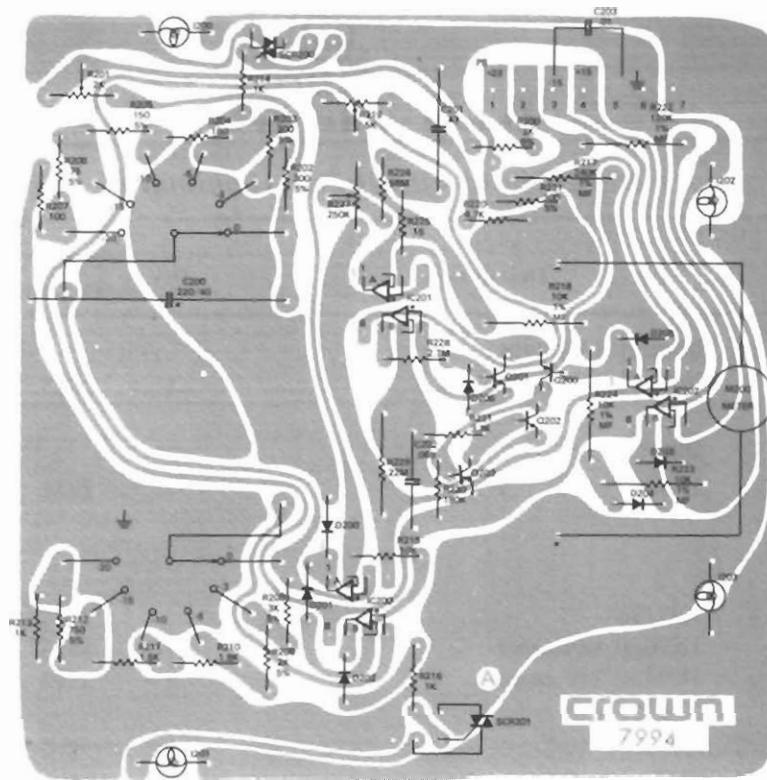

Fig. 6-14. Display Module Printed Circuit Card

Parts List: Display Module Printed Circuit Card

Index No.	Reference Designation	Description	Qty.	CROWN Part No.	Other Information
		Display Module	1	41376	
		Capacitors:			
	C200	220MF, 40V axial	1	4147	
	C201	.47 MF, 100V poly	1	3995	
	C202	.068 MF, 200V filmatic	1	3190	
	C203	.01 MF, ceramic disc	1	1751	
		Diodes:			
	D200, D201, D202, D203, D204, D205, D206	1N4148	7	3181	
	SCR200, SCR201	MAC92-1 triac	2	3811	
		Integrated Circuit:			
	IC200 A, B IC201 A, B IC202 A, B	RC4558 dual op-amp	3	3919	



CROWN
M-600 AMPLIFIER

Parts List: Display Module Printed Circuit Card (Continued)

Index No.	Reference Designation	Description	Qty.	Crown Part No.	Other Information
Resistors:					
	R200, R208	3K ohm, 1/4 watt, 5%	2	3805	
	R201	2K ohm, vertical pot	1	2871	Threshold
	R202, R221	300 Ohm, 1/4 watt, 5%	2	3801	
	R203	200 ohm, 1/4 watt, 5%	1	3800	
	R204	180 ohm, 1/4 watt, 10%	1	2873	
	R205	150 ohm, 1/4 watt, 5%	1	3799	
	R206	75 ohm, 1/4 watt, 5%	1	3798	
	R207	100 ohm, 1/4 watt, 10%	1	2872	
	R209	2K ohm, 1/4 watt, 5%	1	3804	
	R210	1.8K ohm, 1/4 watt, 10%	1	3807	
	R211	1.5K ohm, 1/4 watt, 10%	1	2876	
	R212	750 ohm, 1/4 watt, 5%	1	3509	
	R213, R214, R216	1K ohm, 1/4 watt, 10%	3	2627	
	R215	10K ohm, 1/4 watt, 10%	1	2631	
	R217	240K ohm, 1/2 watt, 1% film	1	3857	
	R218, R223, R224	10K ohm, 1/2 watt, 1% film	3	2343	
	R219	5K ohm, vertical pot	1	1681	Calibrate
	R220	4.7K ohm, 1/4 watt, 10%	1	3939	
	R222	120K ohm, 1/2 watt, 1% film	1	3856	
	R225	15 ohm, 1/4 watt, 10%	1	3614	
	R226	56M ohm, 1/4 watt, 10%	1	3536	
	R227	250K ohm, vertical pot	1	3028	Drift
	R228	2.7M ohm, 1/4 watt, 10%	1	2634	
	R229	22M ohm, 1/2 watt, 10%	1	3052	
	R230	180K ohm, 1/4 watt, 5%	1	4218	
	R231	3.3K ohm, 1/4 watt, 10%	1	2629	
Transistors:					
	Q200, Q201, Q202	2N3859A (selected)	3	2961	
	Q203	2N4125	1	3625	
Miscellaneous:					
		IC socket, 8 pin DIL	3	3451	
		Rotary switch, 1P, 6 position	2	3835	
		Lamp socket, 7-35J	4	3843	
		Ampmod 1 PC bloc, 7-pin	1	3847	
		Ampmod 1 PC housing, 7-pin	Ref	3848	Inserted on 3847
		Ampmod 1 PC receptacle	Ref	3849	Inserted in 3848
		Ampmod 1 PC key pin	Ref	3850	Inserted in 3848
		Lock washer, internal star, No. 6	2	2279	Meter mounting

Table of Circuit Component Functions

Reference Designation	Circuit Function
C302	Part of stabilizing network.
Q325	Output power transistor.
Q326	Output power transistor.
Q327	Output power transistor.
Q328	Output power transistor.
R5	See figure 6-7.
R328	Emitter resistor output power transistor Q325.
R329	Emitter resistor output power transistor Q326.
R330	Emitter resistor output power transistor Q327.
R331	Emitter resistor output power transistor Q328.
R332	Part of stabilizing network.
R333	Sensing temperature for switching to standby mode.

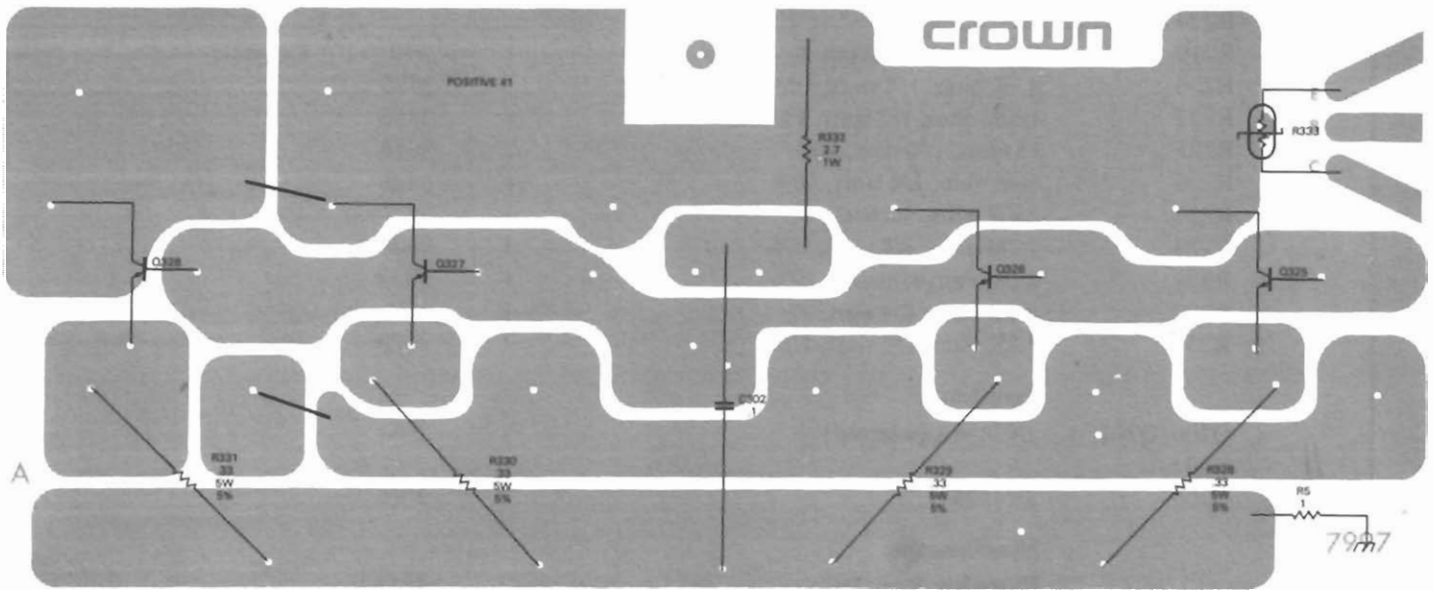

Fig. 6-15. Positive Output No. 1 Printed Circuit Card

CROWN
M-600 AMPLIFIER

Parts List: Positive Output No. 1 Printed Circuit Card

Index No.	Reference Designation	Description	Qty.	Crown Part No.	Other Information
		Capacitors:			
	C302	.1MF, 200V filmatic	1	2938	
		Resistors:			
	R328, R329 R330 R331 R332 R333 R5	.33 ohm, 5 watt, 5% wire	4	3583	
		2.7 ohm, 1 watt, 10%	1	1001	
		TS3-75 thermal sensor, moxie	1	3785	See figure 6-7.
		Transistors:			
	Q325 Q326 Q327 Q328	2N3773	4	3773	Output power transistors
		Miscellaneous Parts:			
		Screw, binding head, phillips, No. 6-32 X 5/8	8	3879	Mounts output transistors
		Nut, hex, No. 6-32	8	1889	Mounts output transistors
		Washer, lock, internal star, No. 6	8	1823	Mounts output transistors
		Heatsink compound, 340	AR	2162	Used around resistor R333 and to mount output transistors
		Blank output PC board	1	7997	

Table of Circuit Component Functions

Reference Designation	Circuit Function
C301	Stabilizing Q319.
D302	Flyback diode.
Q319	Bias control for positive and negative predrivers.
Q320	Output driver.
Q321	Output power transistor.
Q322	Output power transistor.
Q323	Output power transistor.
Q324	Output power transistor.
R322	Biasing base of Q320.
R323	Biasing output power transistors.
R324	Emitter resistor output power transistor Q321.
R325	Emitter resistor output power transistor Q322.
R326	Emitter resistor output power transistor Q323.
R327	Emitter resistor output power transistor Q324.

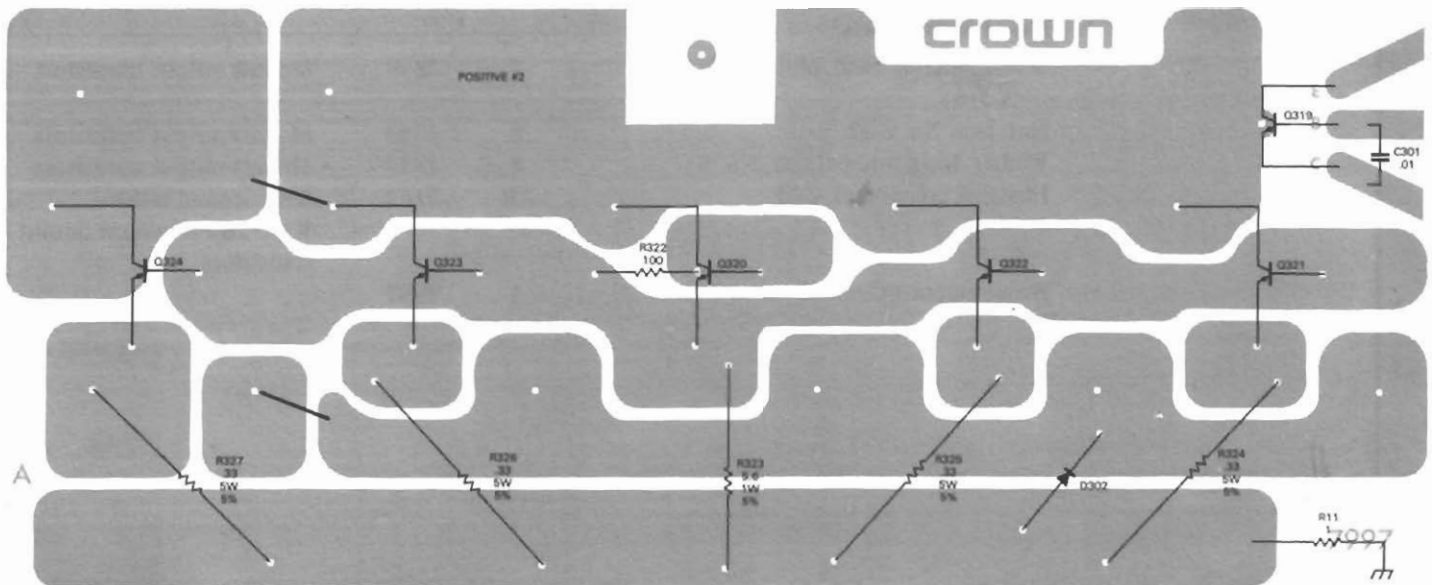

Fig. 6-16. Positive Output No. 2 Printed Circuit Card

CROWN
M-600 AMPLIFIER

Parts List: Positive Output No. 2 Printed Circuit Card

Index No.	Reference Designation	Description	Qty.	Crown Part No.	Other Information
		Capacitors:			
	C301	.01 MF, Ceramic disc	1	1751	
		Diodes:			
	D302	1N5402	1	2941	
		Resistors:			
	R11	1 ohm, 1/2 watt, 10%	1	3612	See figure 6-7.
	R322	100 ohm, 1/4 watt, 10%	1	2872	
	R323	5.6 ohm, 1 watt, 5%	1	2355	
	R324	.33 ohm, 5 watt, 5%, wire	4	3583	
	R325				
	R326				
	R327				
		Transistors:			
	Q319	2N 3859A (selected by Crown)	1	2961	
	Q320	TIP558 (selected by Crown)	1	4025	
	Q321	2N3773	4	3773	
	Q322				
	Q323				
	Q324				
		Miscellaneous Parts:			
		Screw, binding head, phillips, No. 6-32 X 5/8	8	3879	Mounts output transistors
		Nut, No. 6-32	8	1889	Mounts output transistors
		Washer, lock, internal star, No. 6	8	1823	Mounts output transistors
		Heatsink compound, 340	AR	2162	Used to mount transistor Q319 and output transistors
		Insulator, TO-3, anodized	1	3570	Mounts transistor Q320
		Blank output PC board	1	7997	

Table of Circuit Component Functions

Reference Designation	Circuit Function
C300	Stabilizing Q300.
D300	Flyback diode.
Q300	Bias control for positive and negative predrivers.
Q301	Output driver.
Q302	Output power transistor.
Q303	Output power transistor.
Q304	Output power transistor.
Q305	Output power transistor.
R300	Biasing base of Q301.
R301	Biasing output power transistors.
R302	Emitter resistor output power transistor Q302.
R303	Emitter resistor output power transistor Q303.
R304	Emitter resistor output power transistor Q304.
R305	Emitter resistor output power transistor Q305.

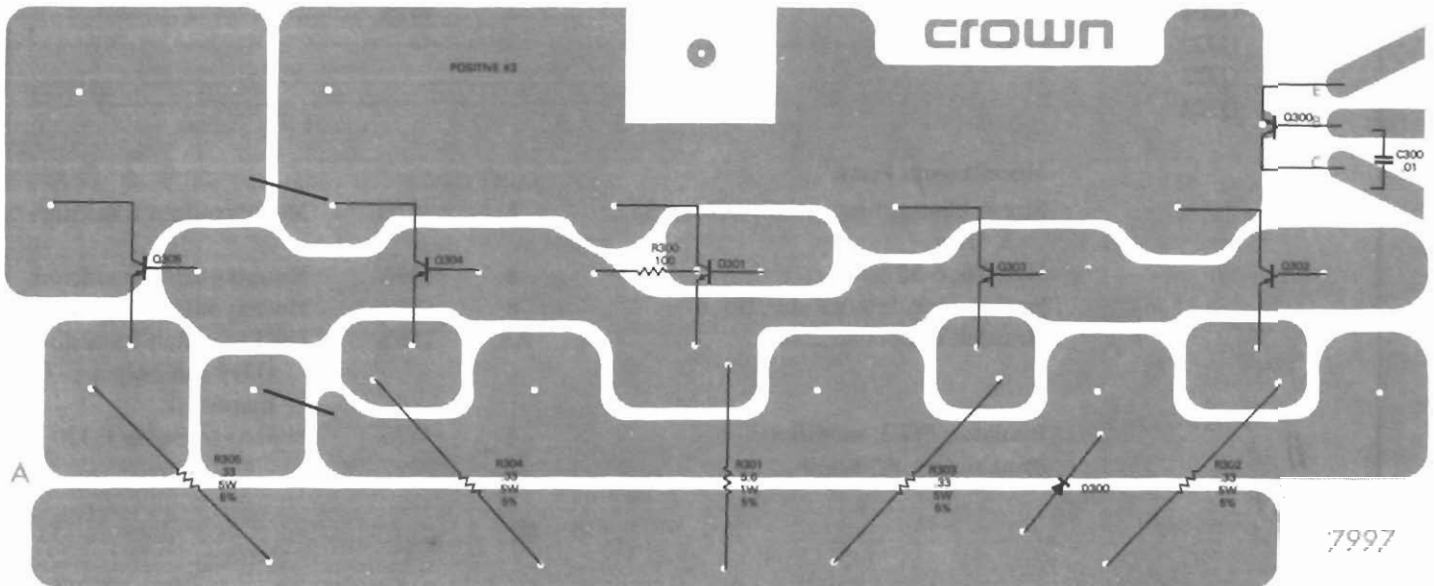

Fig 6-17. Positive Output No. 3 Printed Circuit Card

CROWN
M-600 AMPLIFIER

Parts List: Positive Output No. 3 Printed Circuit Card

Index No.	Reference Designation	Description	Qty.	Crown Part No.	Other Information
		Capacitors:			
	C300	.01 MF ceramic disc	1	1751	
		Diodes:			
	D300	1N5402	1	2941	
		Resistors:			
	R300	100 ohm, 1/4 watt, 10%	1	2872	
	R301	5.6 ohm, 1 watt, 5%	1	2355	
	R302	.33 ohm, 5 watt, 5%, wire	4	3583	
	R303				
	R304				
	R305				
		Transistors:			
	Q300	2N4125	1	3625	
	Q301	TIP558 (selected by Crown)	1	4025	
	Q302	2N3773	4	3773	
	Q303				
	Q304				
	Q305				
		Miscellaneous Parts:			
		Screw, binding head, phillips, No. 6-32 X 5/8	8	3879	Mounts output transistors
		Nut, hex, No. 6-32	8	1889	Mounts output transistors
		Washer, lock, internal star, No. 6	8	1823	Mounts output transistors
		Heatsink compound, No. 340	AR	2162	Used to mount transistors and Q300
		Insulator, TO-3, anodized	1	3570	Mounts transistor Q301
		Blank output PC board	1	7997	

Table of Circuit Component Functions

Reference Designation	Circuit Function
C2	See figure 6-7. Stabilization Network.
Q306	Output power transistor.
Q307	Output power transistor.
Q308	Output power transistor.
Q309	Output power transistor.
R2	See figure 6-7. Stabilization network.
R306	Emitter resistor output power transistor Q306.
R307	Emitter resistor output power transistor Q307.
R308	Emitter resistor output power transistor Q308.
R309	Emitter resistor output power transistor Q309.
R310	Sensing temperature for switching to standby mode.

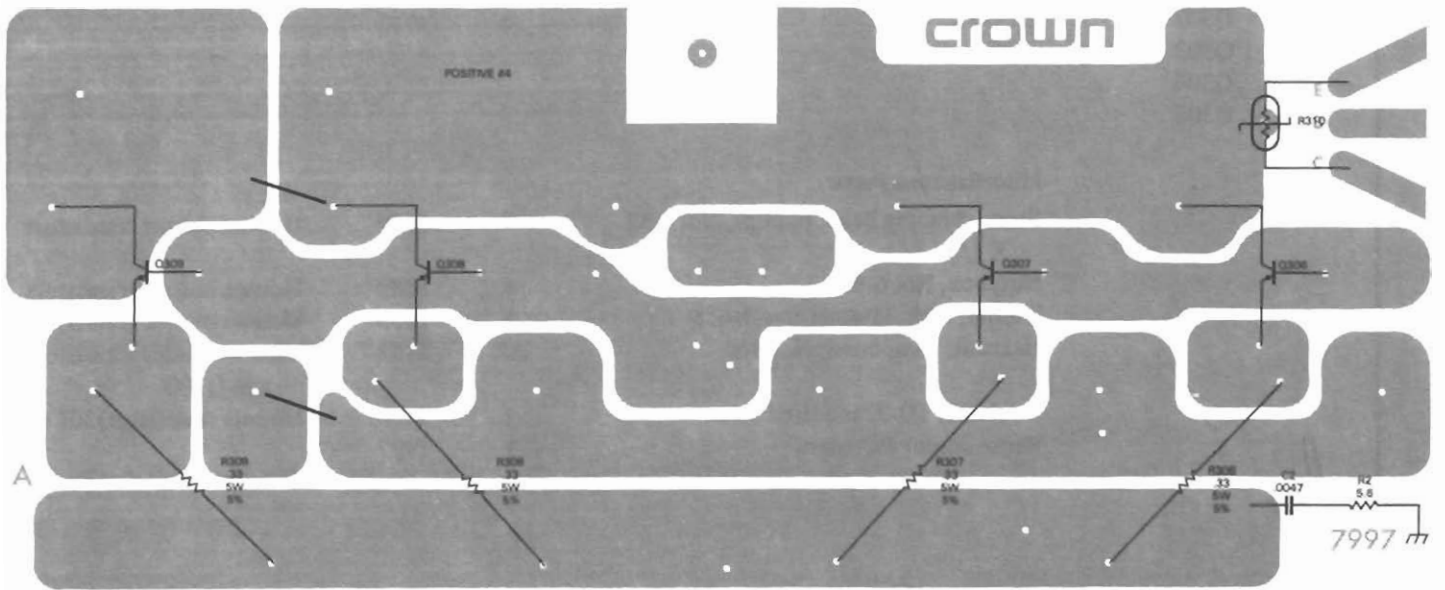

Fig. 6-18. Positive Output No. 4 Printed Circuit Card

CROWN
M-600 AMPLIFIER

Parts List: Positive Output No. 4 Printed Circuit Card

Index No.	Reference Designation	Description	Qty.	Crown Part No.	Other Information
		Capacitors:			
	C2	.0047 MF, 200V poly	1	3996	See figure 6-7.
		Resistors:			
	R2	5.6 ohm, 1/2 watt, 5%	1	3299	See figure 6-7.
	R306	.33 ohm, 5 watt, 5%, wire		3583	
	R307				
	R308				
	R309				
	R310	TS3-75 thermal sensor, moxie	1	3785	
		Transistors:			
	Q306	2N3773	4	3773	
	Q307				
	Q308				
	Q309				
		Miscellaneous:			
		Screw, binding head, philips, No. 6-32 X 5/8	8	3879	Mounts output transistors
		Nut, hex, No. 6-32	8	1889	Mounts output transistors
		Washer, lock, internal star, No. 6	8	1823	Mounts output transistors
		Heatsink compound, 340	AR	2162	Mounts thermal sensor resistor R310 and output transistors
		Blank output PC board	1	7997	

Table of Circuit Component Functions

Reference Designation	Circuit Function
Q315	Output power transistor.
Q316	Output power transistor.
Q317	Output power transistor.
Q318	Output power transistor.
R317	Emitter resistor output power transistor Q315.
R318	Emitter resistor output power transistor Q316.
R319	Emitter resistor output power transistor Q317.
R320	Emitter resistor output power transistor Q318.
R321	Senses output current for protection circuit.

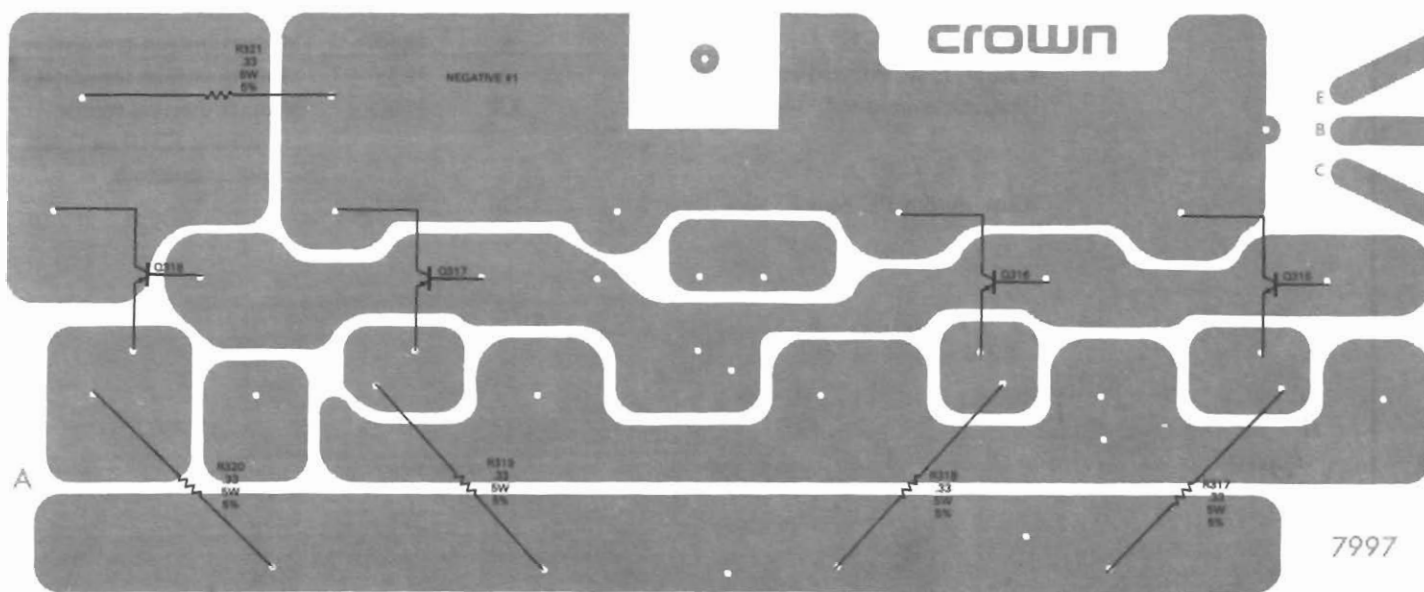

Fig. 6-19. Negative Output No. 1 Printed Circuit Card



CROWN
M-600 AMPLIFIER

Parts List: Negative Output No. 1 Printed Circuit Card

Index No.	Reference Designation	Description	Qty.	Crown Part No.	Other Information
		Resistors:			
	R317	.33 ohm, 5 watt, 5%, wire	4	3583	
	R318				
	R319				
	R320				
	R321				
		Transistors:			
	Q315	2N3773	4	3773	
	Q316				
	Q317				
	Q318				
		Miscellaneous Parts:			
		Screw, binding head, phillips, No. 6-32 X 5/8	8	3879	Mounts output transistors
		Nut, hex, No. 6-32	8	1889	Mounts output transistors
		Washer, lock, internal star, No. 6	8	1823	Mounts output transistors
		Heatsink compound, 340	AR	1262	Mounts output transistors
		Blank output PC board	1	7997	

Table of Circuit Component Functions

Reference Designation	Circuit Function
D301	Flyback diode.
Q310	Output driver.
Q311	Output power transistor.
Q312	Output power transistor.
Q313	Output power transistor.
Q314	Output power transistor.
R311	Biasing base of Q310.
R312	Biasing output power transistors.
R313	Emitter resistor output power transistor Q311.
R314	Emitter resistor output power transistor Q312.
R315	Emitter resistor output power transistor Q313.
R316	Emitter resistor output power transistor Q314.

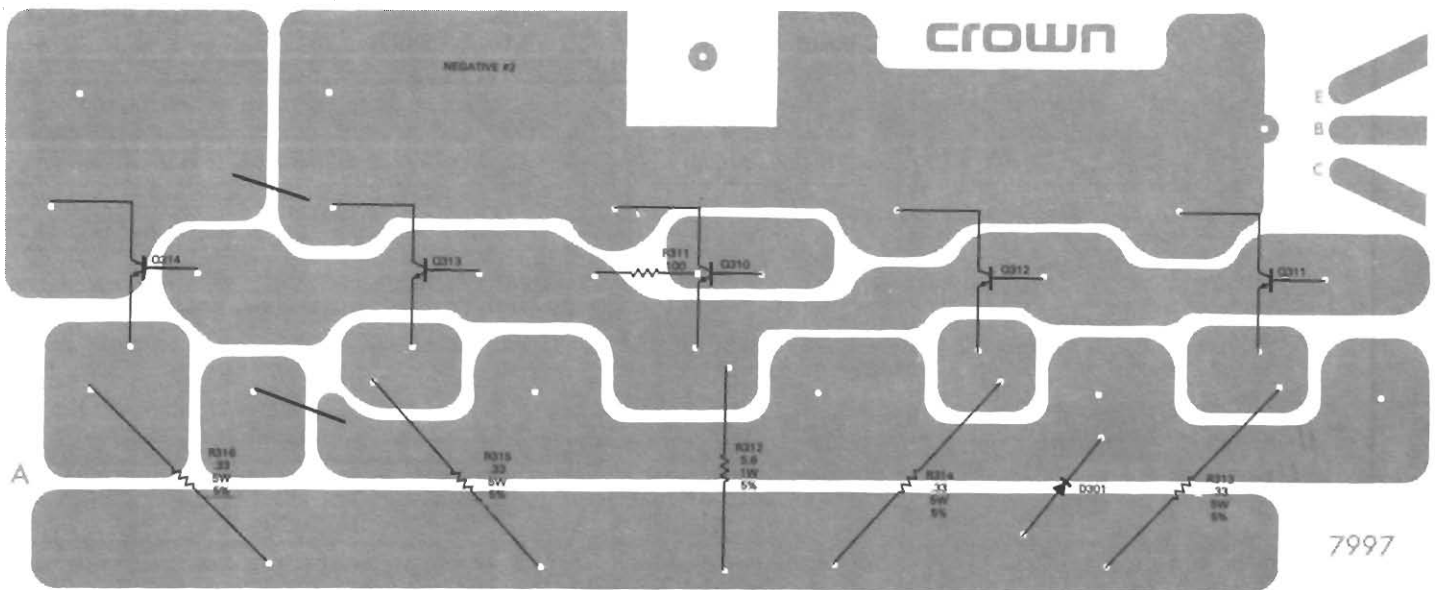

Fig. 6-20. Negative Output No. 2 Printed Circuit Card

CROWN
M-600 AMPLIFIER

Parts List: Negative Output No. 2 Printed Circuit Card

Index No.	Reference Designation	Description	Qty.	Crown Part No.	Other Information
		Diodes:			
	D301	1N5402	1	2941	
		Resistors:			
	R311	100 ohm, 1/4 watt, 10%	1	2872	
	R312	5.6 ohm, 1 watt, 5%	1	2355	
	R313	.33 ohm, 5 watt, 5%, wire	4	3583	
	R314				
	R315				
	R316				
		Transistors:			
	Q310	TIP558	1	4025	
	Q311	2N3773	4	3773	
	Q312				
	Q313				
	Q314				
		Miscellaneous Parts:			
		Screw, binding head, phillips No. 6-32 X 5/8	8	3879	Mounts output transistors
		Nut, hex, No. 6-32	8	1889	Mounts output transistors
		Washer, lock, internal star, No. 6	8	1823	Mounts output transistors
		Heatsink compound, 340	AR	1262	Mounts output transistors
		Insulator, TC-3, anodized	1	3570	Mounts transistor Q310
		Blank output PC board	1	7997	

Table of Circuit Component Functions

Reference Designation	Circuit Function
D303	Flyback diode
Q329	Output driver
Q330	Output power transistor
Q331	Output power transistor
Q332	Output power transistor
Q333	Output power transistor
R334	Biasing base of Q329
R335	Biasing output power transistors
R336	Emitter resistor output power transistor Q330.
R337	Emitter resistor output power transistor Q331.
R338	Emitter resistor output power transistor Q332.
R339	Emitter resistor output power transistor Q333.

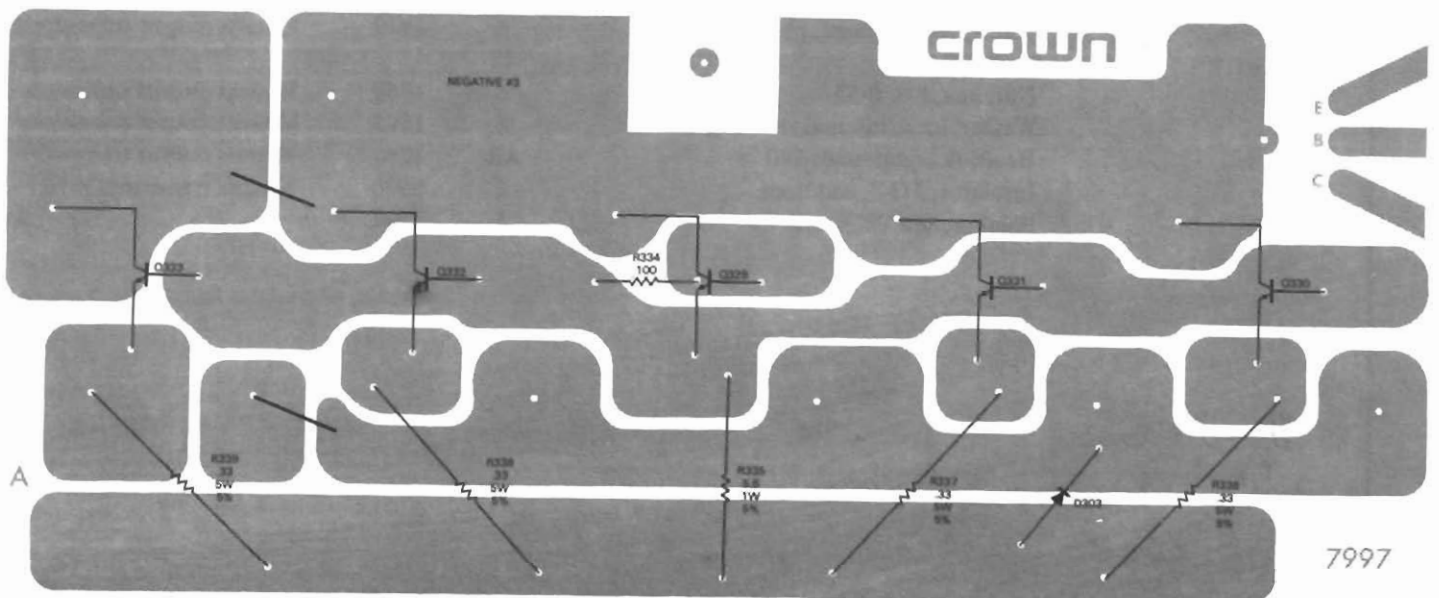

Fig. 6-21. Negative Output No. 3 Printed Circuit Card

CROWN
M-600 AMPLIFIER

Parts List: Negative Output No. 3 Printed Circuit Card

Index No.	Reference Designation	Description	Qty.	Crown Part No.	Other Information
		Diodes:			
	D303	1N5402	1	2941	
		Resistors:			
	R334	100 ohm, 1/4 watt, 10%	1	2872	
	R335	5.6 ohm, 1 watt, 5%	1	2355	
	R336	.33 ohm, 5 watt, 5%, wire	4	3583	
	R337				
	R338				
	R339				
		Transistors:			
	Q329	TIP558	1	4025	
	Q330	2 N3773	4	3773	
	Q331				
	Q332				
	Q333				
		Miscellaneous Parts:			
		Screw, binding head, phillips, No. 6-32 X 5/8	8	3879	Mounts output transistors
		Nut, hex, No. 6-32	8	1889	Mounts output transistors
		Washer, lock, internal star, No. 6	8	1823	Mounts output transistors
		Heatsink compound, 340	AR	2162	Mounts output transistors
		Insulator, TO-3, anodized	1	3570	Mounts transistor Q329
		Blank output PC board	1	7997	

Table of Circuit Component Functions

Reference Designation	Circuit Function
Q334	Output power transistor.
Q335	Output power transistor.
Q336	Output power transistor.
Q337	Output power transistor.
R340	Senses output current for protection circuit.
R341	Emitter resistor output power transistor Q334
R342	Emitter resistor output power transistor Q335
R343	Emitter resistor output power transistor Q336.
R344	Emitter resistor output power transistor Q337.

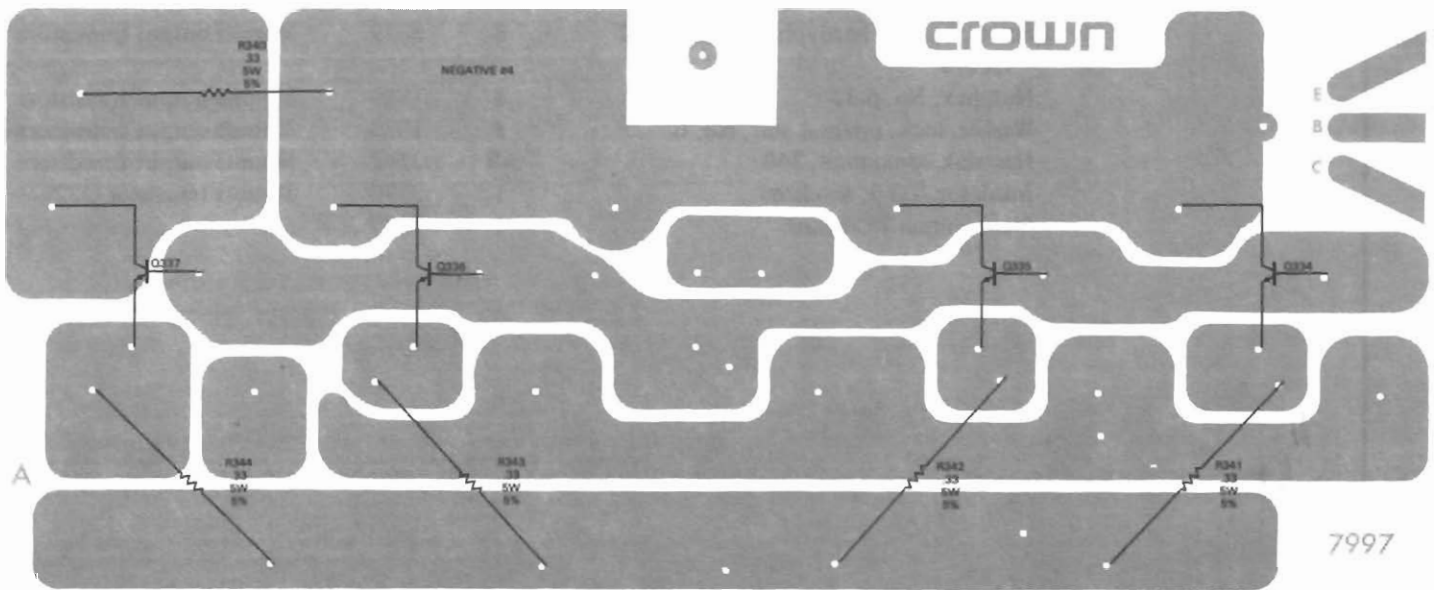

Fig. 6-22. Negative Output No. 4 Printed Circuit Card

CROWN
M-600 AMPLIFIER

Parts List: Negative Output No. 4 Printed Circuit Card

Index No.	Reference Designation	Description	Qty.	Crown Part No.	Other Information
		Resistors:			
	R340	.33 ohm, 5 watt, 5%, wire	5	3583	
	R341				
	R342				
	R343				
	R344				
		Transistors:			
	Q334	2N3773	4	3773	
	Q335				
	Q336				
	Q337				
		Miscellaneous Parts:			
		Screw, binding head, phillips, No. 6-32 X 5/8	8	3879	Mounts output transistors
		Nut, hex, No. 6-32	8	1889	Mounts output transistors
		Washer, lock, internal star, No. 6	8	1823	Mounts output transistors
		Heatsink compound, 340	AR	2162	Mounts output transistors
		Blank output PC board	1	7997	



CROWN
M-600 AMPLIFIER

SECTION 7. MAINTENANCE

7.1. Introduction

This section contains information and data for checkout, troubleshooting, servicing, and repairing the M-600 Amplifier. Included are:

- Required test equipment
- Other test equipment
- Checkout procedures
- Disassembly procedures
- Testing subassemblies and components
- Reassembly procedures

The procedures outlined in this section are intended for use by an experienced technician who has had little or no experience in checking out, servicing, or repairing the M-600 Amplifier. As more experience is gained in this area, less and less reference to the information in this section will be required.

7.2. Required Test Equipment

Many of the servicing and repair problems in the M-600 Amplifier can be performed with a limited amount of test equipment. However, restoration of the M-600 to meet all new equipment performance specifications cannot be guaranteed unless the checkout, servicing, and repair is performed using the recommended test equipment listed in Table 7-1. Instructions for use of the recommended test equipment is contained in the checkout, servicing, and repair procedures. The "Requirements" column in Table 7-1 provides information to allow intelligent selection of substitutes if the "Suggested Supplier and Model" is not available or is considered impracticable to obtain.

NOTE

Meters recommended in Table 7-1 are high quality and can be expected to stay in calibration

with only periodic checks (every 6 months). If lower quality meters are used, they should be checked for calibration before critical or significant measurements are to be made. Equipment required to perform this calibration check (such as Hewlett Packard Model 6920B AC/DC Meter Calibrator, for example) is expensive, and its use is not covered in this manual. The desired end result (assured accuracy in electrical measurements) can thus be obtained by use of high quality test equipment that can be calibrated and trusted (under normal circumstances) to remain in calibration over a reasonable period of time or by use of lower quality test equipment which must be checked (and if necessary recalibrated) before each critical use.

7.3. Other Test Equipment

(Curve Tracer/Transistor Checker). Sometimes in servicing and repairing an M-600 Amplifier, evaluating the performance of an individual semiconductor device may be necessary. Ideally, a curve tracer such as the Tektronix Model 576 can be used for this purpose, though at considerable cost. If a Tektronix Model 561 oscilloscope is available, a plug in unit is available for performing checks on semiconductor devices at substantially less cost. A much less expensive route is to use a transistor checker such as an RCA Model WT-501A, B and K Model 162, EICO Model 667, or equivalent. A stand alone curve tracer adapter for an oscilloscope may also be used, such as the Heath IT1121.

7.4. Identifying Parts

An important aspect of servicing is being able to locate electrical and electronic parts within the M-600 Amplifier. All replaceable parts are illustrated in the parts list illustrations in Section 6 of this manual. Electrical and electronic parts having reference designations assigned on the schematic diagrams are identifiable by this reference designation appearing in the parts list tables "Reference Designation" column.

Table 7-1. Required Test Equipment

Nomenclature	Requirements	Use	Suggested Supplier and Model
Oscilloscope	Dual Trace, capable of displaying a 10 MHz signal	Monitoring output during checkout and servicing	Tektronix Model T922
Volt-ohm Milliammeter	Low-voltage resistance probe (100 mv range); Higher-voltage resistance probe (1.5 volt range)	Checking resistance values (low-voltage probe); checking semiconductor junctions for opens or shorts (higher-voltage probe); checking operating voltages	Triplet Model 601 (includes both voltage probes needed)
Signal Generator	Sine/square wave capability; flat frequency response (including 20 KHz sine and 10 KHz square)	Provide test input signals during checkout and servicing	Wavetek Series 130 or 180
AC Wattmeter	Readable with accuracy of ± 1 watt at 20 watts without cutting into voltage at high power levels (300-line voltage, 60 Hz)	Checking total power input to M-600 Amplifier	Simpson Model 1379
Circuit Breakers	20 amp rating; 120 volt, 60 Hz line, single pole; and 10 amp. rating 240 volt, 50-60 Hz line, single pole	Checkout of defective units to prevent damage if power supply is shorted	Potter & Brumfield Type 112-220-101 (10 amp). Type 112-210-101 (5 amp)
AC Line Monitor	Peak reading meter	Monitoring line voltage during checkout servicing	Available from CROWN
Digital Voltmeter	Capable of reading 0 to 3 volts dc with accuracy of $\pm 0.1\%$; 3-1/2 digits	Used with AC line monitor for monitoring line voltage during checkout and servicing	Weston Model 1220
Variac (Variable Transformer)	Single phase; 120-240 volt, 50-60 Hz line, 20 amp output; or 240-280 volt, 50-60 Hz line, 10 amp output	Controlling input voltage during checkout and servicing	Superior Model 3PN 136B or 3PN 236B
AC Voltmeter	100 Microvolt low voltage 20 Hz to 4 MHz, $\pm 1\%$ accuracy between 100 Hz and 1 MHz	Setting output level during checkout and servicing; checking noise levels	Hewlett Packard Model 400F
Filter	20 Hz to 20 KHz band pass, low noise	Noise level testing	Available from CROWN
Intermodulation Distortion Analyer		Checking intermodulation distortion	Available from CROWN



M-600 AMPLIFIER

Table 7-1. Required Test Equipment (Continued)

Nomenclature	Requirements	Use	Suggested Supplier and Model
Dummy Load	2, 4, and 8 ohms; capable of dissipating 1500 watts; less than 10% reactive component at any frequency up to five times the highest test frequency (5 X 100 KHz = 500 KHz)	Checking output performance	Available from CROWN

7.5. Establishing Problems

User complaints about defective amplifier operation may not always be clear or simple. Furthermore, the trouble the user has experienced may be due to the system and not due to a defective amplifier. If possible, talk to the user about his problem; this will usually be simpler than trying to understand written complaints. A first hand account of the problem can help in:

1. Getting the problem to recur on the service bench.
2. Getting an understanding of the probable cause. Some troubles will be obvious upon visual inspection, such as burned components, blown fuses, or loose electrical connections. When the trouble (or its symptoms) is not so obvious, it may be helpful to know:
 - a. Exactly what was the problem; how was it noticeable?
 - b. How was the amplifier being used?
 - c. Has the system been carefully checked for possible problems external to the amplifier?
 - d. How long had the amplifier been operating when the problem occurred? Did the amplifier seem warmer than usual?
 - e. What kind of signal and what kind of load were involved?
 - f. Did the problem occur once? Frequently? Repeatedly? If it happened more than once were the circumstances the same for all occurrences?

If the user is unavailable or unable to explain the trouble and if the cause is not obvious from visual inspection:

- a. Proceed through the electrical checkout as outlined in this section.
- b. If the amplifier passes all tests with no problems, apply power, signal, and load to the amplifier and begin checking components under operation by tapping them gently and by heating and cooling them. Transistors, diodes, and precision resistors are most likely to cause problems under these conditions if they have been causing problems before.
- c. If none of the above leads to the cause of trouble, operate the amplifier under load for awhile to see if the user's trouble shows up.

7.6 Disassembly for Inspection, Service, Testing, Adjustment and Repair

The extent of disassembly required will of course depend upon the extent of the inspection, service, testing, adjustment, and repair to be performed. The disassembly procedures described below will usually not be required in their entirety. Suggestions as to the extent of disassembly are presented throughout the following disassembly procedures. Illustrations referred to are located in the parts list section of this manual (Section 6).

A fairly complete visual inspection can be performed by removing the back cover (11, figure 6-1), the top cover (8), and the bottom cover (9). To remove these parts, proceed as follows:

1. Remove four slotted hexagon head sheet metal screws (10) which secure the back cover (11) between the side cover (13) and the fan side cover (14) at the rear of the unit. Then take out the three hexagon head sheet metal screws (6) which attach the upper edge of the back cover (11) to the rear flange of the top cover (8). Carefully withdraw the back cover from the unit. This exposes the main module circuit board, the power supply module circuit board and the power relay mounted on the back duct assembly.

2. Remove the three hexagon head sheet metal screws (6, figure 6-1) which secure top cover (8) to the side cover panel (13), and remove the three hexagon sheet metal screws (4) which secure the top cover to the fan side cover (14). Now slide the top cover rearward approximately 1/4 inch until the front edge of the cover disengages from the groove in the upper extrusion at the front of the unit. Withdraw top cover. This exposes the top output panel (containing four positive output circuit boards); the meter module; the upper part of the power supply components mounted behind the front panel; and the power ON-OFF switch, POWER indicator light and STANDBY indicator light.

WARNING

Immediately after removing the bottom cover as described in the following step, discharge the four large capacitors (C6, C7, C8, and C9) by connecting a 10-ohm resistor (not less than 10 watt rating) across the terminals of each capacitor. Failure to heed this warning could result in serious electrical shock or damage to circuit components when handling modules.

3. Remove the two hexagon head sheet metal screws (6) which secure the bottom cover (9) to the side cover (13). Now tip the unit onto its side with the fan side cover (14) up. Remove the two front rubber feet (5). Remove the hexagon head sheet metal screw (6) at the bottom center of the lower extrusion. Remove the two hexagon head sheet metal screws (6) which attach the bottom cover (9) to the fan side cover (14). Pull the back edge of the bottom cover outward slightly; then slide the cover backward until the front edge disengages from the lower extrusion. Withdraw bottom cover (9). This exposes the bottom output panel containing output negative circuit boards, the components mounted on the input control panel at the back of the unit, the bottom portion of the power supply components (rectifiers and transformers, and capacitor connections), and the input control panel and associated connector. After the covers have been removed, all of the internal parts and wiring will be visible to some extent except the wiring and fan motor

located inside the cooling duct. These can easily be made visible by removing the ten hexagon head sheet metal screws (4, figure 6-7) which attach the top output panel heatsink mounting plate (13, figure 6-7) to the front duct panel (12, figure 6-1) and back duct panel (14, figure 6-8). After the screws have been removed, the front edge of the output panel can be raised to allow visual access to the interior of the duct.

Replacement of either of the two large power supply transformers (32, figure 6-3) requires disassembly of the front panel components. To disassemble (after top and bottom covers have been removed), proceed as follows:

1. Unscrew two knurled head retainers (5, figure 6-3) which secure the input control panel assembly to the lower extrusion (15). Grasp knobs on input control panel assembly and pull the assembly straight outward.

2. Remove two binding head screws (8) which secure the meter module assembly to the front panel. Carefully withdraw the meter module from the front panel cutout and disengage wiring harness plug from pins on meter module circuit board.

3. Loosen four oval head screws (1) which secure end bars (4) to ends of panel assembly (24), and disengage end bars from ends of panel assembly.

4. From rear side of panel assembly (24), remove retainers from red and amber lens caps (6 and 7). Withdraw lens caps from front side of front panel.

5. Unscrew retaining ring from power ON-OFF switch.

6. Using an allen wrench, remove 4 socket head screws (9) which secure two handles (10) to front panel assembly (24). Take out short handle spacers (12), and long handle spacers (11).

7. Withdraw lower extrusion (15) from front panel.

8. Remove hexagon nuts (16) and lock washers (17) from four hexagon head screws (18); then withdraw upper extrusion (19) from front panel.

9. Remove four electrolytics (2, figure 6-4) by removing eight screws (4). Note polarities of these capacitors for proper reinsertion.

10. Lift front panel overlay (21, figure 6-3) from front panel assembly (24).

11. Store lower extrusion (15), in a location where it will not be subjected to scratching.

12. Remove seven flat head screws (22) which attach retainer plates (23) and front panel assembly (24) to



CROWN
M-600 AMPLIFIER

front flange of transformer panel, and remove retainer plates.

13. Remove truss head screws (27) and lock washers (28) which secure transformer mounting bracket (35) to side cover and to fan side cover.

14. Disconnect leads of transformers (32) from terminals on capacitors, rectifiers, and terminal strips on transformer mounting panel.

15. Remove three binder head screws (20, figure 6-4) which secure input control panel plug-in shield (23) to transformer mounting panel (26). Swing shield out of the way for access to transformer mounting nuts (29, figure 6-3).

16. Remove eight hexagon nuts (29) and lock washers (30) from mounting studs on transformers (32).

17. Remove four flat head screws (22) from front panel assembly to separate transformer mounting bracket (35) from front panel.

18. Remove hexagon nuts (29) and lock washers (30) from studs (33); then disengage transformer clamp bars (31) from studs. Remove studs (33) to remove transformers (32).

The fan panel assembly (figure 6-2) may be removed as a unit for replacement of fan motor or other fan parts. To remove, proceed as follows:

1. Remove three hexagon head sheet metal screws (6, figure 6-1) at top edge of fan side cover and two hexagon head sheet metal screws at bottom edge which secure the cover to the top and bottom covers respectively. Omit this step if top and bottom covers have been removed.

2. Remove one truss head screw (27, figure 6-3) and lock washer (28) which secure fan panel assembly to transformer mounting bracket (35). Omit this step if front panel components have been removed.

3. Remove three truss head screws (24, figure 6-4) and lock washer (25) which secure fan panel assembly to transformer mounting panel (26). Omit this step if transformer mounting panel has been removed.

4. Remove two slotted hexagon head sheet metal screws (10, figure 6-1) which secure fan panel assembly to back cover (11). Omit this step if back cover has been removed.

5. Remove two slotted hexagon head sheet metal screws (30, figure 6-5) which secure fan side panel assembly to control panel (33).

6. Remove two slotted hexagon head sheet metal screws (10, figure 6-1) which secure fan panel assembly to front duct panel (12), and two screws (13, figure 6-8) which secure the fan panel to the back duct panel (14, figure 6-8).

7. Carefully withdraw fan panel assembly from the unit and unsolder fan motor leads from terminals on terminal strip (7, figure 6-8) mounted on inside surface of back duct panel (14, figure 6-8).

After the fan panel assembly has been removed, the method of disassembly will be obvious by referring to figure 6-2. The foam tape and the fan venturi (5) are held in place in the fan side cover (13) by a fillet of clear silicone sealer which may be cut with a sharp knife and peeled away to allow removal of the foam tape and venturi.

Further disassembly (such as removal of components from back duct assembly, top and bottom output panels, and control panel assembly) should be obvious from inspection of the item and reference to the illustrations in Section 6.

7.7. General Notes on Reassembly

Reassembly is essentially the reverse of disassembly. If in doubt about types and sizes of attaching parts, refer to the appropriate illustration in Section 6. When reassembling, give particular attention to the following:

1. When attaching panels start all the attaching screws before tightening any of the screws. After all screws have been started, tighten each in succession; being careful not to apply too much torque so as to strip threads.

2. When starting sheet metal screws and screws with machine screw threads, be certain that the screw threads engage properly before tightening; thus avoid cross threading or other thread damage which may be difficult to repair.

3. Be sure there is sufficient clearance between sheet metal screw points and internal wiring to prevent possible damage to wire insulation as screws are tightened.

TO 120 VOLTS,
60 Hz FOR
AMPLIFIER
WIRED FOR
120 OR 128
VOLT INPUT

TO 240 VOLTS,
60 Hz, SINGLE
PHASE FOR
AMPLIFIER
WIRED FOR
240, 248, OR
256 VOLT
INPUT

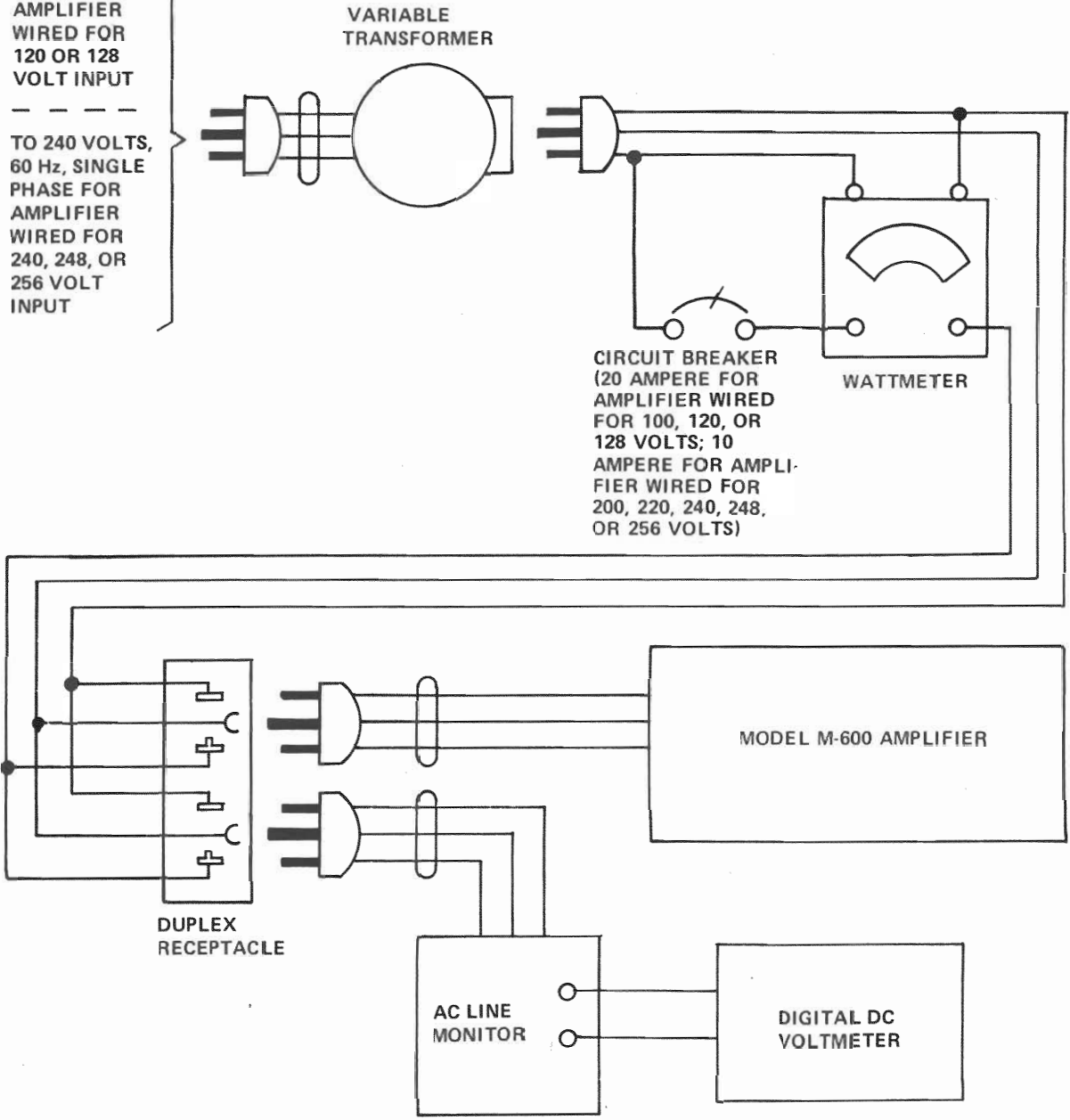

Amplifier Input Voltage	Digital Voltmeter Reading
100 (Note 1)	1.00
120	1.20
128 (Note 1)	1.28
200 (Note 1)	2.00
220 (Note 1)	2.20
240	2.40
248 (Note 1)	2.48
256 (Note 1)	2.56

Note 1. Not all units of the M-600 are capable of being wired for these voltages.

Fig. 7-1. Input Power Connections for Model M-600 Amplifier Checkout and Troubleshooting



CROWN M-600 AMPLIFIER

7.8. Visual Inspection

A thorough visual inspection is recommended prior to servicing, testing, adjusting, and/or repairing the M-600 Amplifier. Make a habit of proceeding in an orderly manner to ensure that no vital part of the visual inspection procedure outlined below is omitted. The visual inspection procedure below can be performed in 10 to 15 minutes. It is recommended both as a preventive maintenance procedure and also for its value in determining causes of malfunctions.

1. Check that all external screws are tight and that none are missing.
2. Check that good fuses of the required type are installed in fuseholders. Fuse requirements are stated according to input voltage on the back cover.
3. Check for smooth operation of switches on meter module, on input control module, and on control panel assembly.
4. Unscrew red and green lens caps from meter module, then remove and check lamp in associated lamp-holders. Replace lamp(s) if burned out and reinstall.
5. Check for any obvious damage to meter on meter module.
6. Inspect line cord for possible damage to cap, to jacket, and to conductors.
7. Check air intake dust filter on right side of the unit. If dirty, remove, wash in dishwashing detergent, dry, and reinstall.
8. Remove rear, top, and bottom covers as outlined in the preceding disassembly instructions (paragraph 7.6).
9. Check that all attaching parts for internal circuit components are tight and that none are missing.
10. Inspect all wiring for charred insulation, or discoloration as evidence of previous overheating.
11. Check that all electrical connections are secure. This includes wire terminals, screw and stud type terminals, and all soldered connections.

12. Check for obvious distortion of internal structural parts such as front and back duct and transformer mounting panel. Distortion in any of these parts could mean that the unit has been dropped or subjected to severe shock.

13. Check for accumulation of dust in the top and bottom output panel finned heat sinks. Blow out dust with compressed air at approximately 40 psi. Aim the compressed air straight into the fins, not obliquely which could distort the fins.

7.9. Electrical Checkout, Troubleshooting and Adjustment

The following instructions outline an orderly checkout and troubleshooting procedure. The purpose and arrangement of this procedure is to determine the cause of trouble as quickly as possible; leading to a detection of which parts must be replaced. Numerous notes have been included in the procedures to aid in an understanding of what is required, to prevent further possible damage to circuit components, and to ensure accurate diagnosis of troubles. The test equipment required to perform the various procedures is listed in Table 7-1.

NOTE ON LINE VOLTAGE AND INPUT POWER. Use the line voltage for which the Amplifier has been wired during all phases of electrical checkout and troubleshooting. Any particular Amplifier with a serial number up to and including 243 may be wired for either 120, 128, 240, 248, or 256 volt, 50-60 Hz single phase input. Any particular Amplifier with a serial number 244 or higher may be wired for 100, 120, 200, 220, or 240 volt, 50-60 Hz single phase input. The voltage for which the amplifier was originally wired is stamped on the nameplate; however field changes by the user are possible and instructions are presented in Section 3 of this manual. With the top, bottom, and rear covers removed, verify the voltage for which the particular Amplifier is wired by comparing the wiring and jumpers with the instructions and diagrams in Section 3. Input voltage must be accurately controlled throughout all phases of electrical checkout and troubleshooting. The setup for controlling input voltage and monitoring input power is shown in Figure 7-1. All items of test equipment shown in Figure 7-1 are described in Table 7-1. When the ac line monitor is used, the dc voltmeter will read 1/100 of the RMS voltage applied to the Amplifier under test. Input voltages and corresponding voltmeter readings are shown in the chart in figure 7-1.

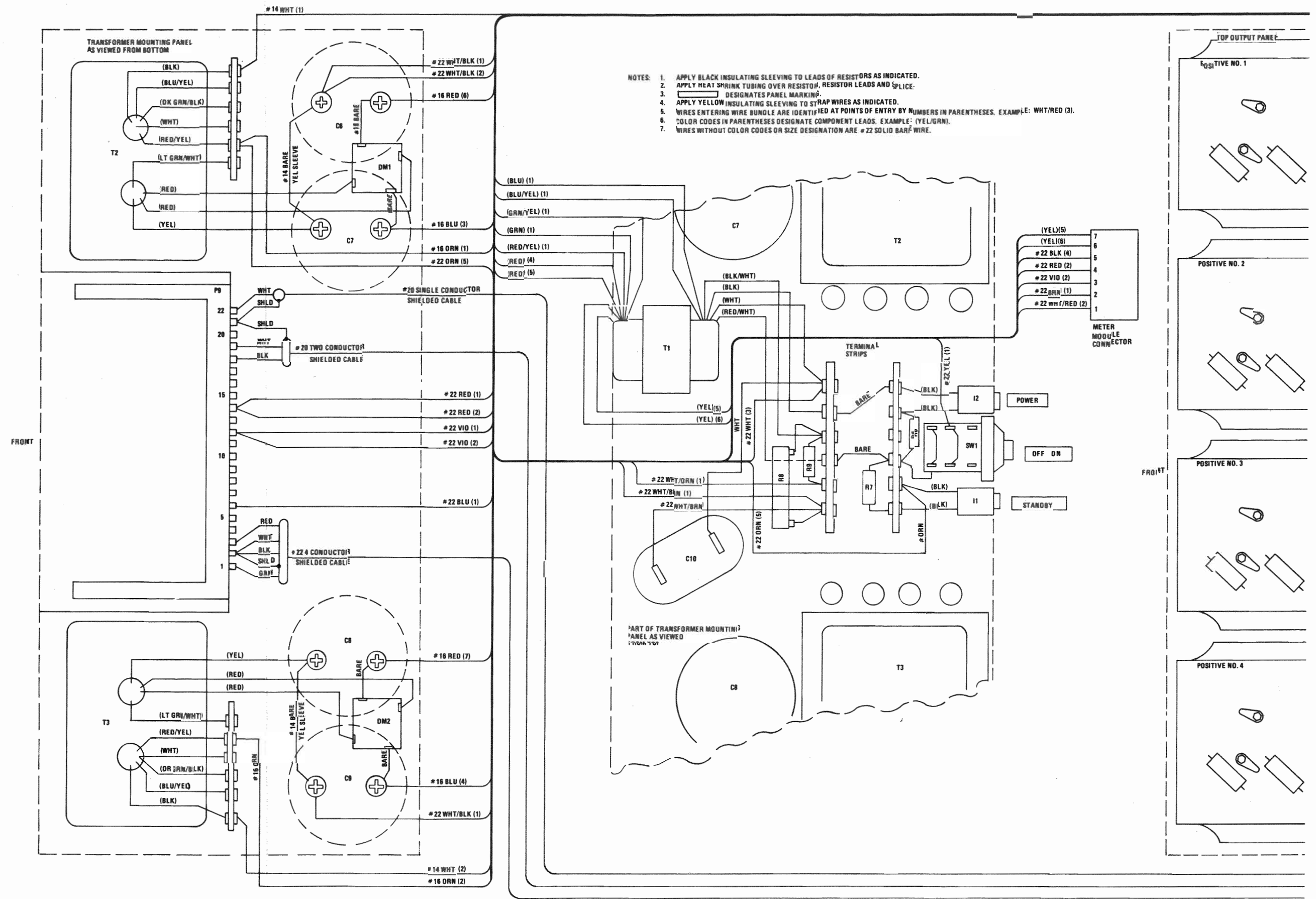

Fig. 7-2. M-600 Amplifier Wiring Diagram (Sheet 1 of 2)

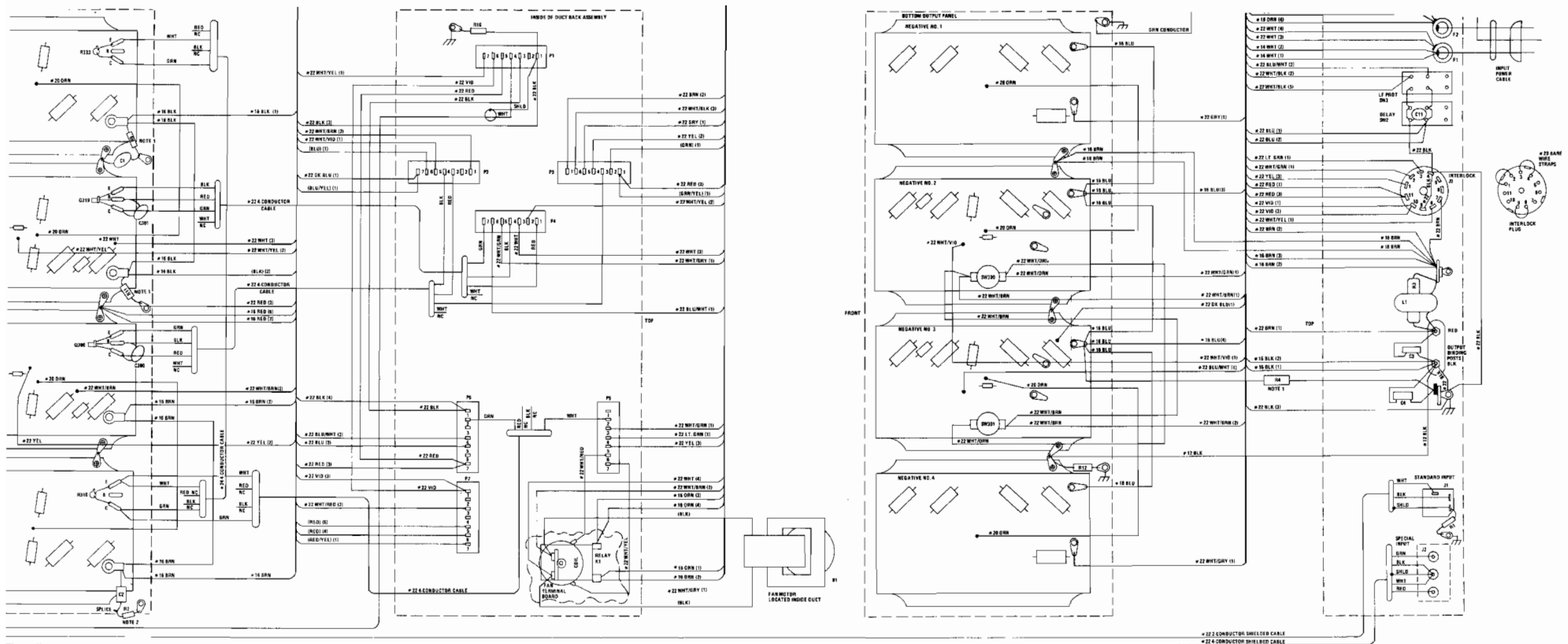

Fig. 7-2. Model M-600 Amplifier Wiring Diagram (Sheet 2 of 2)

7.9.1 TURN-ON CHECKOUT (NO INPUT SIGNAL AND NO LOAD)

The purpose of this procedure is to determine whether the Amplifier will accept input power under no input signal and no load conditions without drawing excessive current. Ordinarily, the Amplifier should not be operated with a signal or load applied until it is capable of performing properly without signal and load. If there is a serious problem within the Amplifier, application of signal and load will probably intensify the problem by blowing fuses and damaging other circuit components.

1. Be sure the input power Switch on the Amplifier is in the OFF position.

2. Check that interlock plug (wired as shown in Figure 7-2) is inserted into socket J3F.

3. Connect input power and test equipment to the Amplifier as shown in Figure 7-1.

4. Adjust the variable transformer to obtain reading on the dc digital voltmeter corresponding to the line voltage of the Amplifier (See Note on line voltage and input power).

5. Close the circuit breaker.

6. Set delay and low frequency protection slide switches on rear of Amplifier to the down (off) positions.

7. Switch amplifier power switch to ON position.

8. If necessary, readjust the variable transformer to maintain the designated input line voltage.

9. Check for the following conditions as evidence of proper operation.

a. Red POWER indicator light on front panel is on.

b. Fan is running at low speed.

c. Power relay K1 mounted on back duct assembly is energized.

d. Amber STANDBY indicator light on front panel is off.

e. Circuit breaker should remain closed.

f. Maximum power should not exceed 80 watts.

g. Proper voltages and test point locations are shown in figure 7-3.

7.9.2 POWER CONTROL MODULE CHECKOUT AND ADJUSTMENT

The purpose of this checkout and adjustment procedure is to verify operation of the power control module and associated circuits and to properly adjust the sensitivity of the Amplifier to high line voltage. In addition to the test equipment shown in figure 7-1, this checkout and adjustment procedure requires a signal generator and a volt-ohm-milliammeter. These items of equipment are described in Table 7-1.

1. Preliminary Steps

a. Be sure input power ON OFF switch is in the OFF position.

b. Remove the plug from the meter module and remove main module and power control module (PC boards).

c. Connect input power and test equipment to the Amplifier as shown in Figure 7-1.

d. Short together main module plug P1 pins 1, 2, and 3, in Figure 7-3.

2. Inspection and Installation

a. Inspect power control module to ensure that all components are correctly oriented, that none show damage of any type and that all are securely soldered. Also check that all soldering is free of bridges and that there are no copper slivers or burrs causing bridgings, especially in the area of the input and output pins.

b. Install the inspected power control module.

3. Checkout and Adjustment Procedures

a. Set the delay and low frequency protection switches on the back of the Amplifier to the off (down) positions.

b. Turn over-voltage adjust variable resistor R414 on power control module (See Figure 6-13 for location) to maximum resistance.

c. Operate the circuit breaker to ON and adjust the variable transformer to obtain the proper reading on the digital voltmeter corresponding to the line voltage of the Amplifier.

d. Depress Amplifier power ON OFF switch several times and check that relay K1 (see Figure 7-3 for location) is energized immediately each time power switch is operated to ON.

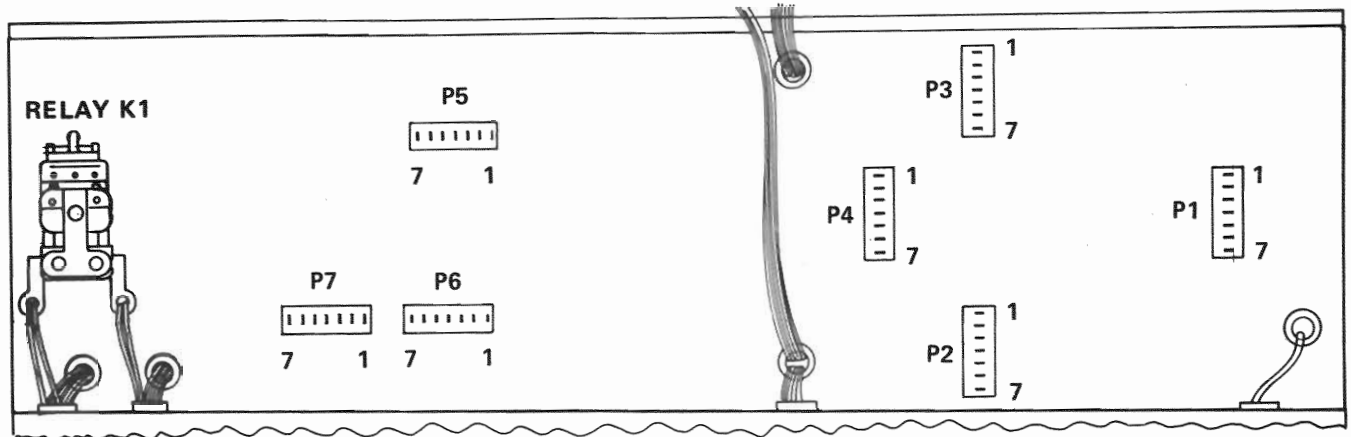

CROWN
M-600 AMPLIFIER

BACK DUCT ASSEMBLY
 (AS SEEN FROM REAR OF AMPLIFIER WITH BACK COVER REMOVED)

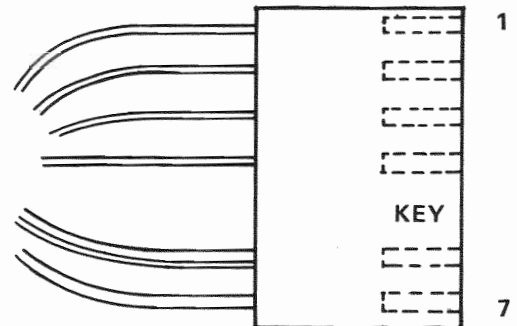

**POWER CONTROL MODULE AND MAIN
 MODULE REMOVED FOR CLARITY**

ALL VOLTAGES WITH REFERENCE TO P.S. GND, P6-1	
+15 Vdc	P1-5, P6-7, P8-4
-15 Vdc	P1-6, P7-1, P8-3
+24 Vdc	P5-6
-24 Vdc	P7-4
+23 Vdc	P7-3, P8-1



METER MODULE PLUG

Fig. 7-3. Model M-600 Amplifier Voltage Test Points

e. Operate the delay switch to the on (up) position.

f. Depress power switch to ON position and check that relay K1 is energized after a delay of 4 to 5 seconds. Also check that STANDBY indicator light on the front panel is on before relay K1 is energized and is off when relay K1 is energized.

g. Using a volt-ohm-milliammeter, check that voltage between main module pin P1-6 (negative) and P1-2 (positive) is 15 ± 0.5 volts dc and that voltage between P1-5 (positive) and P1-2 (negative) is 15 ± 0.5 volts dc.

h. Set the delay switch to the off (down) position. Hold a temporary jumper across the leads of thermal sensor R310 on No. 1 positive output module. Relay K1 should be de-energized immediately. Remove jumper; relay K1 should be energized immediately. Repeat for thermal sensor R333 on the No. 4 positive output module.

i. Remove the interlock plug from J3 on the back of the Amplifier. Relay K1 should be de-energized immediately. Replace the plug; relay K1 should be energized immediately.

j. Using the variable transformer, increase the input line voltage by 10%. Now slowly decrease the resistance in R414 until relay K1 is de-energized. Return the input voltage to the original value. Relay K1 should be energized before the original input line voltage is reached and should remain energized.

k. Set the low frequency protection switch on the back of the amplifier to the on (up) position.

l. Using the signal generator, apply a 1 Hz sine wave at 8 to 12 volts peak-to-peak to control module pin P3-6. Check that relay K1 is de-energized by peaks of either polarity.

m. Operate power switch to OFF position.

NOTE: IMPORTANT BEFORE PROCEEDING:

Discharge capacitors C6, C7, C8, and C9 on the transformer mounting panel by connecting a 10 ohm, 10 watt resistor across the terminals of each capacitor.

7.9.3 MAIN MODULE CHECKOUT AND ADJUSTMENT

The purpose of this checkout and adjustment is to check out operation of the main module and associated circuits and to adjust the output and input offset potentiometers, static balance and dynamic balance potentiometers, and the bridge bias. In addition to the test equipment shown in Figure 7-1, this procedure requires a signal generator, a dual trace oscilloscope, a volt-ohm-milliammeter, and 2, 4, and 8 ohm dummy loads. These items of test equipment are described in Table 7-1.

NOTE ON CHECKING DIODES AND TRANSISTORS WITH AN OHMMETER. Diodes and transistors should be checked with an ohmmeter having a 1.5 volt test voltage. Also, it is important to know which lead of the ohmmeter is positive and which is negative. Good diodes will show 5 to 15 ohms forward resistance (assuming 10 ohms is a mid-scale reading) and a very high reverse resistance. The approximate values of transistor resistance measurements are shown in the following chart. The values apply to a transistor by itself outside the circuit. High resistance means there will be little or no indication on an ohmmeter R X 1 ohm scale. The first lead in the chart listings takes the positive probe for an NPN transistor or negative probe for a PNP transistor.

Base-Emitter	5 to 15 ohms
Emitter-Base	High
Base-Collector	5 to 15 ohms

Collector-Base	High
Collector-Emitter	High
Emitter-Collector	High

NOTE ON TEST EQUIPMENT GROUNDING. Whenever possible, avoid ground loops in the test equipment caused by connecting the output ground to the input ground. Never connect the ground of the cable going to the load back to the input ground. Ground loops are especially obnoxious when measuring distortion. An IM analyzer, for example has its input and output terminals tied to a common ground. Such a test should use an ungrounded output return with the output lead wrapped around a well-shielded and grounded input cable.

NOTE ON LOADING. The dummy loads must be resistive, having less than 10 percent reactive component at any frequency up to five times the highest test frequency (10 KHz) specified in the following procedures. The load must be capable of continuously dissipating the full output of the Amplifier while maintaining its resistance within 1 percent of its rated value. The load must employ only high-current connectors and be connected to the binding post output terminals of the Amplifier.

NOTE ON OUTPUT MEASUREMENTS. All output measurements must be taken at the Amplifier output binding post terminals and not anywhere along the output cable to the dummy load.

1. Preliminary Inspection and Installation

a. Visually inspect the main module for misoriented or damaged components, loose solder connections, broken component leads, and possible solder bridges.

b. Check all protection circuit diodes and transistors (especially the ground side of bridge devices) for normal forward and reverse resistance using an ohmmeter.

c. With no input power applied to the Amplifier, insert the main module.

NOTE

LOW FREQUENCY PROTECTION and DELAY slide switches on rear of Amplifier may be set to either position.

2. Setup

a. Connect input power and test equipment to the Amplifier as shown in Figure 7-1.

b. Connect a dc voltmeter across the Amplifier output terminals.

CROWN
M-600 AMPLIFIER

c. Operate Amplifier power switch to ON position and adjust the variable transformer to obtain the proper reading on the dc digital voltmeter corresponding to the line voltage of the Amplifier (see NOTE on line voltage and input power).

d. Set INPUT ATTENUATOR control on front of Amplifier at 10.

1. Adjusting Output and Input Offset Potentiometers

a. Set INPUT COUPLING switch on front of Amplifier to DC position and adjust output offset potentiometer R115 to obtain zero reading on voltmeter connected across output. See Figure 6-12 for location of R115 on main module.

b. Set INPUT COUPLING switch to AC position and adjust input offset potentiometer R100 (see Figure 6-12 for location of R100 on main module) to obtain zero reading on voltmeter connected across output.

c. Switch INPUT COUPLING rapidly between DC and AC positions and check that voltmeter connected across output shows no variations.

4. Adjusting Static Balance Potentiometers

a. Disconnect voltmeter lead from output black binding post and connect it to Vcc common on main module (pin P3-6).

b. Adjust static balance potentiometer R117 on main module (see Figure 6-12 for location) to obtain a null indication on voltmeter connected between Vcc common and output.

c. Disconnect voltmeter from Vcc common and reconnect it to Amplifier output terminal (black binding post).

d. Connect one probe of a dual trace oscilloscope to Vcc common (pin P3-6) and other probe to Amplifier output binding post.

e. Connect Amplifier output binding posts to an eight-ohm dummy load.

f. Using a signal generator, apply a 1 KHz sine wave to the Amplifier input jack.

g. Set INPUT COUPLING switch on front of Amplifier to AC position.

h. Check that oscilloscope traces as shown in Figure 7-4 can be obtained by rotating INPUT ATTENUATOR control on front of Amplifier. Check that as control is rotated, the larger waveform (representing the output) is always twice the amplitude of the smaller waveform (representing Vcc common). This should occur for all settings of the INPUT ATTENUATOR control between zero amplitude of the waveforms and the point at which clipping starts to occur. Check that the waveforms are undistorted (that is the sides do not start to pull in before clipping occurs). Clipping should be sharp with no ringing or other oscillation.

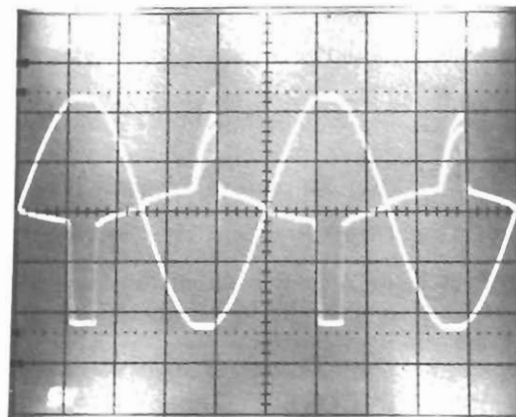

Fig. 7-4. Waveforms Produced by Model M-600 Amplifier with Properly Adjusted Bridge

5. Adjusting Dynamic Balance Potentiometer and Checking Protective Clipping

a. Remove oscilloscope probe from Vcc common and attach it to junction of resistors R151 and R152 on main module (see figure 6-12 for location of resistors) which is the output of bridge balance operational amplifier IC100B.

b. With eight ohm dummy load connected, set the INPUT ATTENUATOR control on the front of the Amplifier clockwise to the point where clipping of the output starts to occur (see figure 7-5). Adjust dynamic balance potentiometer R122 on main module (see figure 6-12 for location) to obtain oscilloscope trace as shown in

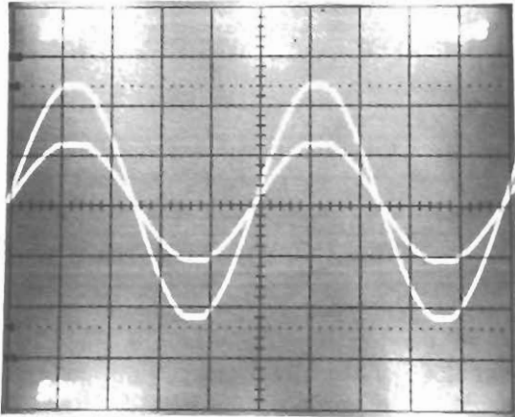

Fig. 7-5. Model M-600 Output and Bridge Balance Operational Amplifier Outputs when Properly Balanced

shown in figure 7-6. Trace should be stable and slew rates should be 16 volts per micro-second or higher.

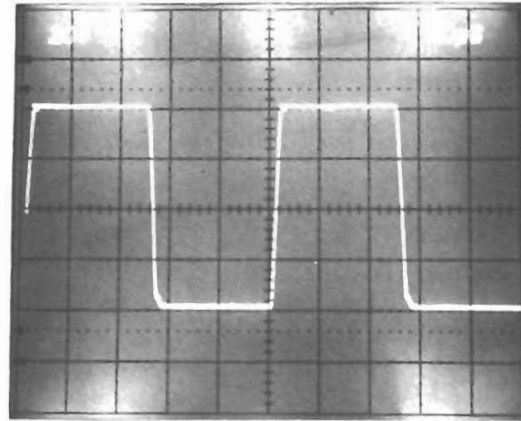

Fig. 7-6. Model M-600 Amplifier Output Waveform with 10 KHz Square Wave Input and 8 Ohm Load

figure 7-4. Note that when proper adjustment is reached, the negative spike of IC100B output is saturated but that the positive spike is not saturated.

c. Switch the Amplifier output to a four-ohm dummy load. Check that clipping of the output signal remains clean and that the bridge remains balanced. There should be no ringing.

d. Switch the Amplifier output to a two-ohm dummy load. Clipping of output signal should be as shown in figure 7-4. There should be no ringing.

NOTE ON PROTECTIVE CLIPPING. When driving a two-ohm ($\pm 1\%$ impedance, the output power at 60 volts would be $\frac{60^2}{2} = 1800$ watts. This output is sufficient to

cause enough power supply sag to clip the output, but the clipping will not be sharp which is indicative of protective circuit clipping. This can be checked by slowing the oscilloscope trace and looking for power supply ripple at the clip level. Presence of ripple indicates that the protective circuit(s) limiter is not turning on and the protective circuit is defective.

6. Checking Slew Rate

a. Switch output to an eight-ohm dummy load, and, using the signal generator, apply a 10KHz square wave signal to the Amplifier input jack. Connect oscilloscope probe to Amplifier output.

b. Set INPUT ATTENUATOR to obtain an output of approximately 200 watts. Check that output trace is as

7. Checking and Adjusting Bridge Bias

a. Disconnect all test equipment from Amplifier input jack and output binding posts. Leave input line power connected and power switch ON.

NOTE ON BIAS CHECKING. The Amplifier should be thoroughly warmed up at quiescent conditions before the bridge bias is measured. This applies equally to initial checkout and to checking to verify results of adjustments. The voltage will begin to climb at turn-on, will peak, and gradually drop to the stable level during warmup. Measurements taken during warmup are likely to be misleading.

b. Using a volt-ohm-milliammeter on a low range dc volts scale, measure voltage drop across resistor R301 on the positive output board No. 3 (see Figure 6-17 for location). Voltage should be within the range of 0.31 to 0.37 volt dc.

c. Also measure the voltage drop across resistor R323 on positive output board No. 2 (see figure 6-16 for location). Voltage should be within the range of 0.31 to 0.37 volt dc.

d. If necessary to adjust the bias on the positive output board No. 3, substitute a higher or lower value of resistor for R164 on the main module (see figure 6-12 for



CROWN
M-600 AMPLIFIER

location). If necessary to adjust the bias on positive output board No. 2, substitute a higher or lower value of resistor R169 on the main module (see figure 6-12 for location). Increasing the value of the resistor lowers the bias, decreasing the value raises the bias. Usually the value of R164 and R169 will fall within the range of 33 ohms to several hundred ohms.

c. After completing the checkout and adjustment of the bias voltage, operate power switch to OFF position.

7.9.4 METER MODULE CHECKOUT AND ADJUSTMENT.

The purpose of this checkout is to verify operation of the meter module including the meter movement, indicator lights, and electronic circuit and to adjust the threshold, calibration, and drift potentiometers. In addition to the test equipment shown in Figure 7-1, this procedure also requires a signal generator, and ac voltmeter, a dc voltmeter, and an oscilloscope. The test equipment is described in Table 7-1.

1. Visual Inspection and Installation

a. Check printed circuit board for orientation of components, for possible damage to components, for possible solder bridges, and for loose electrical connections.

b. Check that nuts securing printed circuit board to meter terminals are tight.

c. Install meter module in front panel of Amplifier and connect wiring plug to meter module. Secure meter module with two screws.

d. With Amplifier in normal operating orientation, check that meter pointer is at small 0 at left end of scale. If it is not, turn meter pointer adjusting screw clockwise until pointer is at small 0.

2. Setup

a. With test equipment connected to Amplifier power input as shown in Figure 7-1, connect an ac voltmeter to the Amplifier output terminals and a signal generator to the Amplifier input jack.

b. Operate the Amplifier OFF ON power switch to ON and adjust the input line voltage (using the variable transformer) to the voltage for which the Amplifier is wired.

c. Check that the meter illuminating lamps are on.

d. Set the Amplifier INPUT COUPLING switch to the AC position and apply a 1 KHz sine input signal.

3. Meter Calibration

a. Set the Amplifier INPUT ATTENUATOR control to obtain a 70.7 volt output.

b. Adjust potentiometer R219 on the meter module printed circuit board (see figure 6-14 for location) so that meter pointer is at 0 db.

4. Adjusting Drift Potentiometer

a. Turn drift potentiometer R227 on the meter module printed circuit board (see figure 6-14 for location) fully clockwise as viewed from top.

b. With a sensitive ac coupled oscilloscope connected to the output of the meter operational amplifier IC201A output at potentiometer R219 slider, turn drift potentiometer R227 slowly counterclockwise until wave ceases jumping.

5. Adjusting Threshold Potentiometer

a. Set dB BELOW MAX. and dB BELOW RED switches on meter module to 0 positions.

b. Adjust INPUT ATTENUATOR control to increase output voltage to 77.8 volts.

c. Adjust threshold potentiometer R201 on the meter module (see Figure 6-14 for location) so that red dB BELOW MAX. indicator light on meter module just turns on.

6. Additional Checks

a. Using the dB scale on a dc meter, check dc potentials around dB BELOW MAX. and dB BELOW RED switches. Plus or minus one dB tolerance between adjacent switch positions is acceptable.

b. Rotate INPUT ATTENUATOR up and down. The meter should ascend smoothly, but should hold momentarily before descent.

7.9.5 INTERMODULATION DISTORTION CHECKOUT

The purpose of this procedure is to verify that the intermodulation distortion of the Amplifier does not exceed specified limits. In addition to the test equipment shown in Figure 7-1, the test equipment shown in Figure 7-7 is also required. All test equipment is described in Table 7-1.

NOTE ON TEST EQUIPMENT. In making these tests it is important to know the residual distortion and noise levels of all test equipment in order to accurately evaluate the intermodulation distortion within the Amplifier.

1. Setup

- a. Connect input power and test equipment to the Amplifier as shown in Figure 7-1.
- b. Connect an eight-ohm dummy load and an intermodulation analyzer to the Amplifier input and output as shown in Figure 7-7.
- c. Operate Analyzer ON OFF power switch to ON and set line voltage to correspond with voltage for which the Amplifier has been wired.

2. Checkout Procedure

a. With the eight-ohm dummy load connected measure the distortion at output levels of 600, 190, 60, 19, 6, 1.9, 0.6, 0.19, 0.06, and 0.019 watts. The distortion must be less than 0.01 percent at the 600, 190, 60, 19, 6, 1.9, and 0.6 watt level and less than 0.05 percent at the 0.19, 0.06, and 0.019 watt levels. The 60Hz LF output will be 55.4 Vrms at 600 watts.

b. Substitute the four-ohm dummy load for the eight-ohm dummy load. Measure the distortion at output levels of 1200, 379, 120, 37.9, 12, 3.79, 1.2, 0.379, 0.12 and 0.0379 watts. The distortion must be less than 0.01 percent at the 1200, 379, 120, 37.9, 12, and 3.79 watt levels and less than 0.05 percent at the 1.2, 0.379, and 0.0379 watt levels. The 60Hz LF will be 55.4 Vrms at 1200 watts.

7.9.6 NOISE LEVEL CHECKOUT.

In addition to the power input test equipment shown in figure 7-1, the test equipment shown in figure 7-8 is also required. The test equipment is described in Table 7-1.

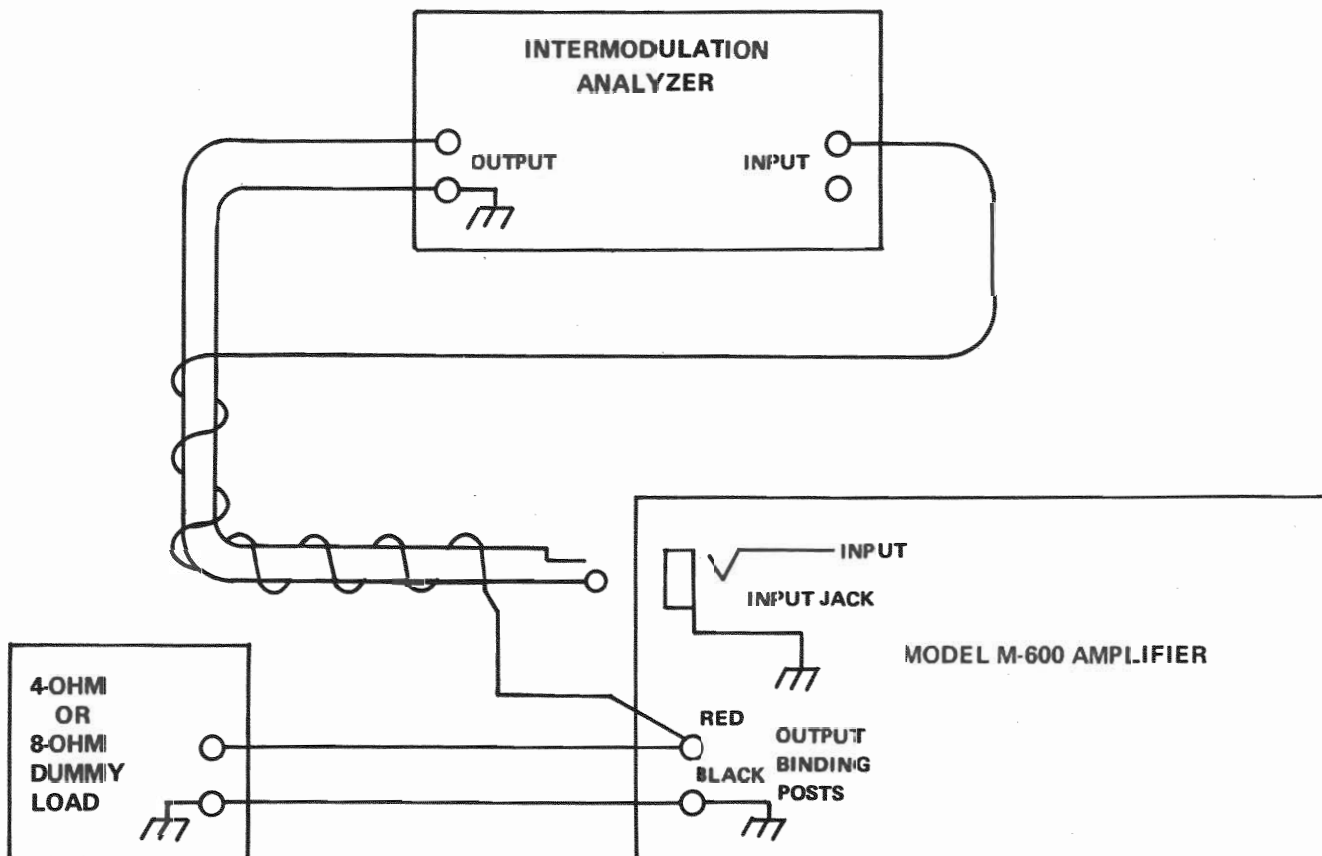

Fig. 7-7. Test Setup for Measuring Model M-600 Amplifier Intermodulation Distortion

CROWN
M-600 AMPLIFIER

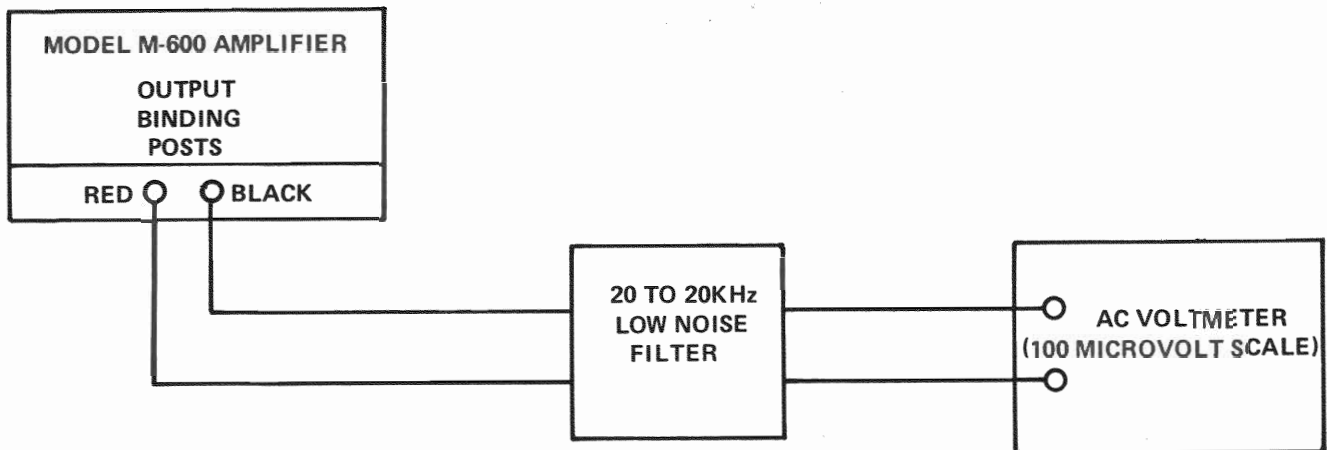

Fig. 7-8. Setup for Measuring Model M-600 Amplifier Noise Level

1. Setup

- a. Connect input power and test equipment to the Amplifier as shown in figure 7-1.
- b. Connect test equipment to the Amplifier output binding posts as shown in figure 7-8.
- c. Be sure that no input is connected to the Amplifier input jack.

2. Checkout Procedure

- a. Operate Amplifier power ON OFF switch to ON and adjust line voltage to correspond to voltage for which Amplifier is wired.
- b. Set INPUT ATTENUATOR on front of Amplifier to full clockwise position.
- c. Measure the noise level relative to 600 watts. Noise level must be at least 130 dB below 600 watts or 69.3 Vrms.

7.9.7 THERMAL PROTECTION CHECKOUT

The purpose of this checkout is to verify proper operation of the thermal switches located on negative output modules No. 2 and No. 3 and the thermal sensors mounted on positive output modules No. 1 and No. 4. In addition to the power input test equipment shown in

figure 7-1, this procedure also requires a signal generator. All test equipment is described in Table 7-1.

1. Setup

- a. Connect input power and test equipment to the Amplifier shown in figure 7-1.
- b. Connect a signal generator to the Amplifier input jack.
- c. Connect a shorting jumper between the Amplifier output binding posts.

2. Checkout Procedure

- a. Operate Amplifier power ON OFF switch to ON, and adjust the line voltage to correspond to the voltage for which the Amplifier is wired.

NOTE

Be prepared to take immediate action by operating the power switch to OFF if the conditions of this test are not met and output modules start to overheat.

- b. Using the signal generator apply a 1/2 Hz sine wave input to the Amplifier.

- c. Set INPUT ATTENUATOR control in the full clockwise position.

d. Check that the fan shifts from low-speed to high-speed. This should occur within approximately 60 to 100 seconds.

e. Block airflow by placing a piece of cardboard over the air filter. Observe that the output modules will begin to heat up rapidly. Check that Amplifier goes into standby mode. This should occur within approximately 15 to 30 seconds after blocking the airflow.

f. Leaving airflow blocked, check that Amplifier cycles between "on" and "standby".

g. Remove cardboard from air filter and remove jumper from output binding posts. Check that output modules cool down and that fan returns to low-speed operation.

7.10. Repair Instructions

Repair of the Amplifier includes replacement of damaged wiring, replacement of parts on any of the removable modules (meter module, input module, power module, main module, and output modules), replacement of any chassis mounted electrical parts, and replacement of any structural parts such as panels and brackets. All replaceable parts are listed in Section 6 of this manual. All replaceable parts except those mounted on printed circuit boards are illustrated on exploded views in Section 6. The exploded views serve two functions: they illustrate the replaceable parts, and they show the relationship of parts as an aid to disassembly and reassembly. The associated parts lists contain the circuit reference designations which aid identifying the circuit parts on the electrical schematics and on the wiring diagram (figure 7-2). Disassembly beyond the point shown by the exploded views (except for replacement of parts on the printed circuit boards) is not recommended.

7.10.1 CONSUMABLE MATERIALS

Consumable materials (except for wire and cable) required in repairing the amplifier are listed in Table 7-2. The use of these materials is explained in the following repair procedures. Some of the items listed in Table 7-2 are also shown in the parts lists in Section 6.

7.10.2 REPAIR OF WIRING

When repair of wiring is necessary or if wiring is disconnected to allow removal of components, refer to the wiring diagram in Figure 7-2 when replacing wires or cables or when reconnecting after replacing components. All wires, cables, and jumpers are identified by color code

and conductor size on the wiring diagram. Component designators correspond to those used on the electrical schematics. Insulation sleeving colors and size (where used) are also shown on the wiring diagram and are listed in Table 7-2. Various terminating devices are illustrated on the parts list illustrations in Section 6 of this manual. Use solder specified in Table 7-2 when soldering electrical connections.

7.10.3 REPAIR OF PRINTED CIRCUIT BOARDS

The power module, main module, meter module and the eight output modules are repairable using ordinary printed circuit board repair techniques. All replaceable parts are listed in Section 6 of this manual and the locations are shown on the parts lists illustrations. When repairing these boards, give particular attention to the following:

1. Use solder specified in Table 7-2.

2. When replacing output or driver transistors [on output modules, carefully scrape away residue of heat sink compound from transistor mounting surface on heat sink after the transistor has been removed. Apply a thin coat of heat sink compound specified in Table 7-2 to mounting surface of transistor to be installed. Use heat sink compound sparingly so that it does not squeeze into electrode holes in heat sink as mounting screws are tightened. After screws have been tightened, solder the connections and remove any heat sink compound that has been squeezed out around the transistor case.

3. When replacing temperature sensing transistors Q300 or Q319 on the positive output module No. 2 or No. 3, imbed the cases in heat sink compound (specified in Table 7-2) applied to the depressions for transistors in the upper surface of the printed circuit boards.

4. When replacing thermal sensor R310 or R333 on positive output module No. 1 or No. 4, apply a small quantity of heat sink compound specified in Table 7-2 to thermal sensor case before pressing the sensor into the module printed circuit board.

7.10.4 REPLACING BAFFLES

Fish paper baffles (12, figures 6-6 and 6-7) partially block airflow through positive output module No. 4 and negative output module No. 4 which are located closest to the fan. These baffles are cemented to the inside surface of the heat sink mounting plates. If replacement is required, cement new baffles in place with a silicone sealer specified in Table 7-2. Be sure the baffles are centered with respect to the heat sink cutout in the mounting plate.



CROWN M-600 AMPLIFIER

Table 7-2. Consumable Materials

Name	Crown Part Number	Use
Heat sink compound (Type 340)	2162	Mounting output transistors on output modules Mounting thermal sensors and temperature sensing transistors on positive output modules Mounting predriver transistors on main module
Silicone sealer (clear)	3010	Mounting heat sink on last voltage amplifier transistor Q106 on main module Mounting heat sink on IC400 on power module Sealing fan venturi in side panel Cementing fish paper to output assemblies
Foam tape	2859	Mounting fan venturi in side panel Mounting transformers T2 and T3 to front panel
Insulation Sleeveing black (0.022 ID)	1644	As specified on wiring diagram
Insulation sleeveing, black (0.042 ID)	1363	Insulating lead; of resistors R5, R11 and R12 on output modules
Insulation sleeveing, black (0.133 ID)	1383	As specified on wiring diagram
Insulation sleeveing, yellow (0.85 ID)	1375	Insulating jumper straps on capacitors C6, C7, C8, and C9
Solder (50/50 rosin core)	3482	Soldering electrical connectors in wiring and on printed circuit boards