

# **D-75**

## **DUAL-CHANNEL POWER AMPLIFIER**

# **SERVICE MANUAL**

CROWN INTERNATIONAL, INC. 1718 W. MISHAWAKA RD. ELKHART, IN 46517-4095

© 1989 Crown International, Inc.  
K80186A6  
3/89

# FULL THREE-YEAR WARRANTY

## SUMMARY OF WARRANTY

We, CROWN INTERNATIONAL, INC., 1718 West Mishawaka Road, Elkhart, Indiana 46517-4095 (Warrantor) warrant to you, the ORIGINAL PURCHASER AND ANY SUBSEQUENT OWNER of each NEW Crown product, for a period of three (3) years from the date of purchase by the original purchaser (warranty period) that the product is free of defects in materials or workmanship and will meet or exceed all advertised specifications for such a product.

## ITEMS EXCLUDED FROM WARRANTY

We are not responsible for product failure caused by misuse, accident or neglect. This warranty does not extend to any product on which the serial number has been defaced, altered, or removed. It does not cover damage to loudspeakers or any other products resulting from Crown product failure. It does not cover defects or damage caused by your use of unauthorized modifications, parts, or service. It also excludes batteries and damage caused by leaky or defective batteries.

## WHAT WE WILL DO

We will remedy any defect in materials or workmanship by repair, replacement, or refund. We may not elect refund unless you agree, or unless we are unable to provide replacement, and repair is not practical or cannot be timely made. If a refund is elected, then you must make the defective or malfunctioning component available to Crown free and clear of all liens or other encumbrances. The refund will be equal to the actual purchase price, not including interest, insurance, closing costs, and other finance charges less a reasonable depreciation on the product from the date of original purchase. Warranty work can only be performed at our authorized service centers or at the Crown factory. We will remedy the defect and ship the product from the service center or Crown factory within a reasonable time after receipt of the defective product at the authorized service center or Crown factory. All expenses in remedying the defect, including surface shipping costs in the United States, will be borne by Crown. (Purchaser must bear the expense of shipping the product between any foreign country and the port of entry in the United States and all taxes, duties, and other custom's fee for such foreign shipments.)

## HOW TO OBTAIN WARRANTY SERVICE

You must notify us of your need for warranty service not later than ninety (90) days after expiration of the warranty period. We will give you written notice of the dealer service centers to whom you may deliver the product, or we will give you an authorization to return it for factory service. All components must be shipped in a factory pack, which, if needed, may be obtained from Crown free of charge. Corrective action will be taken within a reasonable time of the date of receipt of the defective product by us or our service center. If the repairs made by Crown or the authorized service center are not satisfactory, notify Crown or the authorized service center immediately.

## DISCLAIMER OF CONSEQUENTIAL AND INCIDENTAL DAMAGES

YOU ARE NOT ENTITLED TO RECOVER FROM US ANY CONSEQUENTIAL OR INCIDENTAL DAMAGES RESULTING FROM ANY DEFECT IN OUR PRODUCT. THIS INCLUDES ANY DAMAGE TO ANOTHER PRODUCT OR PRODUCTS RESULTING FROM SUCH A DEFECT. SOME STATES DO NOT ALLOW THE EXCLUSION OR LIMITATIONS OF INCIDENTAL OR CONSEQUENTIAL DAMAGES, SO THE ABOVE LIMITATION OR EXCLUSION MAY NOT APPLY TO YOU.

## WARRANTY ALTERATIONS

NO PERSON HAS THE AUTHORITY TO ENLARGE, AMEND, OR MODIFY THIS WARRANTY. THE WARRANTY IS NOT EXTENDED BY THE LENGTH OF TIME WHICH YOU ARE DEPRIVED OF THE USE OF THE PRODUCT. REPAIRS AND REPLACEMENT PARTS PROVIDED UNDER THE TERMS OF THIS WARRANTY SHALL CARRY ONLY THE UNEXPIRED PORTION OF THIS WARRANTY.

## DESIGN CHANGES

We reserve the right to change the design of any product from time to time without notice and with no obligation to make corresponding changes in products previously manufactured.

## LEGAL REMEDIES OF PURCHASER

THIS WARRANTY GIVES YOU SPECIFIC LEGAL RIGHTS, AND YOU MAY HAVE OTHER RIGHTS WHICH VARY FROM STATE TO STATE. No action to enforce this Warranty shall be commenced later than ninety (90) days after expiration of the warranty period.

CROWN INTERNATIONAL, INC.  
1718 West Mishawaka Road, Elkhart, Indiana 46517-4095.

**THIS STATEMENT OF WARRANTY SUPERSEDES ALL OTHERS CONTAINED IN THIS MANUAL.**

The information furnished in this manual does not include all of the details of design, production, or variations of the equipment. Nor does it cover every possible situation which may arise during installation, operation or maintenance. If you need special assistance, beyond the scope of this manual, please contact the Crown International Customer Services Department.

**Crown International, Inc.**

1718 West Mishawaka Road  
Elkhart, Indiana 46517-4095

Phone: (219) 294-8000

Fax: (219) 294-8FAX

Twx: (810) 294-2160

**WARNING**

TO PREVENT SHOCK OR FIRE HAZARD,  
DO NOT EXPOSE TO RAIN OR MOISTURE!

**CAUTION**

TO PREVENT SHOCK DO NOT USE THE POLARIZED AC  
PLUG OF THIS UNIT WITH AN UNPOLARIZED EXTENSION  
CORD, RECEPTACLE OR OTHER OUTLET WHERE THE  
BLADES CANNOT BE FULLY INSERTED.

**ATTENTION**

POUR PREVENIR LES CHOCS ELECTRIQUES NE PAS UTILISER  
CETTE FICHE POLARISEE AVEC UN PROLONGATEUR. UNE  
PRISE DE COURANT OU UNE AUTRIE SORTIE DE COURANT,  
SAUF SI LES LAMES PEUVENT ETRE INSEREES A FOND SANS  
EN LAISSER AUCUNE PARTIE A DECOUVERT.

# Table of Contents

<b>1 Introduction</b> .....	1-1	<b>7 Specifications</b> .....	7-1
1.1 The D-75.....	1-1	7.1 General.....	7-1
1.2 Warranty.....	1-1	7.2 Monaural.....	7-1
<b>2 Facilities</b> .....	2-1	7.3 Stereo.....	7-2
<b>3 Required Test Equipment</b> .....	3-1	7.4 Performance Graphs.....	7-4
<b>4 Maintenance</b> .....	4-1	<b>8 Schematics</b> .....	8-1
4.1 Safety First.....	4-1	<b>9 Parts</b> .....	9-1
4.2 Inspection.....	4-1	9.1 General Information.....	9-1
4.3 Disassembly.....	4-1	9.2 Standard and Special Parts.....	9-1
4.4 Reassembly.....	4-2	9.3 Ordering Parts.....	9-1
4.5 Troubleshooting.....	4-2	9.4 Shipment.....	9-1
<b>5 Voltage Conversion</b> .....	5-1	9.5 Terms.....	9-1
<b>6 Circuit Theory</b> .....	6-1	9.6 Illustrated Parts Lists.....	9-2
6.1 Block Diagram Circuit Theory.....	6-1	<b>Appendix A: Installation</b> .....	A-1
6.2 Balanced/Unbalanced Input Stage.....	6-2	A.1 Mounting.....	A-1
6.3 Input Operational Amplifier.....	6-2	A.2 Wiring.....	A-1
6.4 Signal Translator.....	6-2	A.2.1 Stereo.....	A-1
6.5 Final Voltage Amplifier.....	6-3	A.2.2 Monaural.....	A-1
6.6 Bias.....	6-3	A.3 Input.....	A-1
6.7 Output Stage.....	6-3	A.4 Output.....	A-2
6.8 Protection Circuitry.....	6-3	A.5 Load Protection.....	A-3
6.9 IOC™ (Input/Output Comparator).....	6-4	<b>Appendix B: Operation</b> .....	B-1
6.10 Signal Presence Indicator.....	6-4	B.1 Precautions.....	B-1
		B.2 Controls.....	B-1
		B.3 Protection.....	B-1
		B.4 Fuse Replacement.....	B-2

## Illustration

1.1 D-75.....	1-1
2.1 Front Facilities (D-75).....	2-1
2.2 Rear Facilities (D-75).....	2-2
4.1 2 Ohm Load Waveform.....	4-3
4.2 10KHz Square Wave.....	4-3
4.3 20KHz Sine Wave.....	4-3
4.4 IM Distortion Test Set-up.....	4-4
4.5 Signal to Noise Test Set-up.....	4-4
5.1 AC Mains Voltage Conversion.....	5-1
6.1 D-75 Block Diagram.....	6-1
6.2 Balanced Input Stage.....	6-2
6.3 Input Operational Amplifier.....	6-2
6.4 Signal Translator.....	6-2
6.5 Final Voltage Amplifier.....	6-3
6.6 Bias, Output and Protection Stages.....	6-3
6.7 IOC.....	6-4
6.8 Signal Presence Indicator.....	6-4
7.1 Power Matrix.....	7-3
7.2 Nominal Frequency Responce.....	7-4
7.3 Nominal Output Impedance.....	7-4
7.4 Nominal Phase Responce.....	7-5
7.5 Nominal Power Efficiency.....	7-5
7.6 Nominal Damping Factor.....	7-6
7.7 Nominal Output Phase Angle.....	7-6
7.8 Nominal Crosstalk.....	7-7
7.9 Nominal Noise Spectrum.....	7-7
8.1 D-75 Schematic Diagrams.....	8-1
9.1 D-75 Main Modules.....	9-2, 3
9.2 Output Module.....	9-9
9.3 D-75 Front Panel Assembly.....	9-11,
.....	12, 13
9.4 D-75 Neon Bracket Assembly.....	9-16
9.5 D-75 Back Panel Assembly.....	9-17
9.6 D-75 Capacitor Bracket Assembly.....	9-19
9.7 D-75 Final Assembly.....	9-20
A.1 D-75 Mounting Dimentions.....	A-1
A.2 Input High Pass Filter.....	A-2
A.3 Input Low Pass Filter.....	A-2
A.4 Wire Gauge Nomograph.....	A-3
A.5 Connection to an Inductive Load.....	A-3
A.6 Fuse Nomograph.....	A-4

**This Page Left Blank Intentionally**



Fig. 1.1 D-75

## 1 Introduction

This manual contains complete service information on the Crown D-75 power amplifier. It is designed to be used in conjunction with the D-75 Instruction Manual. However, some important information is duplicated in this Service Manual in case the Instruction Manual is not readily available.

**NOTE: THE INFORMATION IN THIS MANUAL IS INTENDED FOR USE BY AN EXPERIENCED TECHNICIAN ONLY!**

### 1.1 The D-75

The D-75 amplifier is a compact, audio power amplifier designed for professional use. Providing medium power amplification from 20Hz-20KHz with minimum distortion, the unit features balanced inputs, signal presence and IOC™ indicators, monophonic capability and a means for isolating electrical ground from chassis ground.

### 1.2 Warranty

Product that is covered by warranty must be serviced by an Authorized Crown Service Center or at the Crown Factory Service Department. Any questions concerning warranty policy should be directed to the attention of Technical Service Department at:

#### **Crown International, Inc.**

1718 W. Mishawaka Road  
Elkhart, Indiana 46517-4095  
Phone: (219) 294-8000  
FAX: (219) 294-8329  
Twx: (810) 294-2160

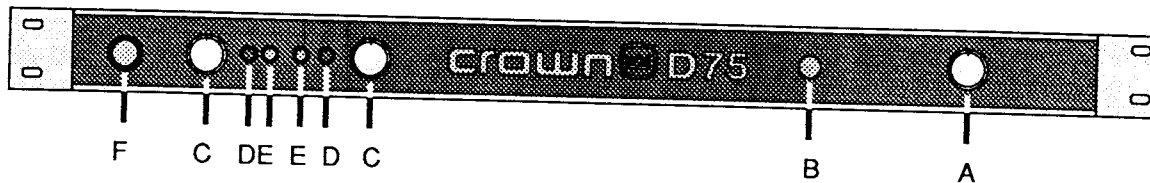

FIG. 2.1 FRONT FACILITIES (D-75)

## 2 Facilities

### A. Power

The AC power switch, mounted at the right-hand corner of the D-75 is a simple 2 position "on/off" control. If the AC power switch is positioned at "on", the power indicator should be on (B).

### B. Power Indicator

Amber indicator that the unit is on.

### C. Level

The level of each channel is independently controlled by these controls. The control for channel 2 should be turned down and not used when operating in MONO mode.

### D. IOC™

An Input/Output Comparator LED is provided for each channel. Illumination may occur at such times as when there is too high an input level, improper load impedance, output stage clipping or even an amplifier based problem.

### E. Signal Presence Indication

A signal presence indication LED is provided for each channel to indicate when signal is present. Unlike the "on/off" state of the IOC indicators the SPI LED's will vary with signal level

### F. Output Monitor

A standard 1/4 inch stereo jack is provided on the front panel. It is in parallel with the main outputs (G) and can be used to drive headphones.

### G. Output Binding Posts

Dual binding postconnectors are provided at the output of each channel. Use dual banana plugs on the speaker cables for connection to the jacks. In bridged-MONO, only the two top jacks (red) are used.

### H. Dual-Mono

Slide this switch to the left (ch. 1) for MONO mode and to the right (ch. 2) for Stereo mode operation. In MONO mode the input and level control for channel two should not be used and only balanced (ungrounded) loads should be connected to the output jacks.



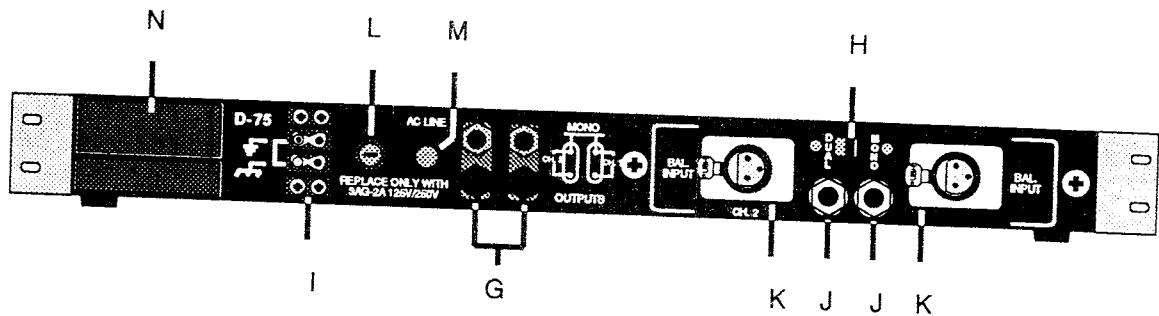

FIG. 2.2 Rear Facilities (D-75)

### I. Ground Barrier Strip

Isolation of chassis ground from signal ground is easily accomplished by removing the shorting strap from this terminal strip. This may help remove any hum problems caused by "ground loops." (Circuit ground is isolated from chassis ground by 2.7 ohms.)

### J. Input Phone Jack

An unbalanced 1/4 inch phone jack is provided at the input of each channel. Do not use the input jack for channel 2 in MONO mode.

### K. Balanced-Input Receptacle

A balanced XLR connector is provided at the input of each channel.

### L. Fuse

The AC line is safety fused. If the unit is configured for 100VAC or 120VAC operation, a 2 amp fuse is used and if set up for 200VAC, 220VAC or 240VAC, a 1 amp fuse is used. The use of any other fuse value will invalidate the warranty.

### M. Power Cord

A standard three-wire (grounded) AC cord with a 15 amp plug are provided.

### N. Serial Number Sticker

**This Page Left Blank Intentionally**

### 3 Required Test Equipment

Many of the service and repair problems with the D-75 can be performed with a limited amount of test

equipment. However, in order to return the unit to its "factory new" specifications, the following list of required test equipment is recommended. The "Requirements" column provides information to allow intelligent selection of substitutes if the "Suggested Supplier and Model" is not available or is considered impractical to obtain.

Equipment	Requirements	Application	Suggested Model
Oscilloscope	Capable of displaying a 10MHz signal	Monitoring output during service and testing	Tequipment D54A or equivalent
Volt-Ohmmeter	Low-voltage resistance probe 100mv (range). High-voltage resistance probe (1.5V range)	Check resistance values (low voltage probe). Check semiconductor junctions for opens or shorts (high voltage probe) Check DC voltages	Fluke 8024 or equivalent
Freq. Counter		For accurate general monitoring	Heath SM118A
Signal Generator	Sine/Square wave available; flat frequency response. THD .1% maximum	Provide test signals for service and checkout	Wavetek 130 -Series or equivalent
Circuit Breaker	15 ampere rating	In AC line to unit; protects circuitry from overload if power supply has shorted	
AC Line Voltage Monitor	Peak reading meter (displays rms equivalent to a sinusoidal peak for any waveform)	Monitor Line voltage	Circuit available from Crown

**This Page Left Blank Intentionally**

## 4. Maintenance

Effective repair involves three basic steps: 1) Determine the symptom(s) of the problem; 2) Identify the cause(s) of the symptom(s); 3) Repair the unit to eliminate the cause(s). Before proceeding through these steps it is highly recommended that you first observe the safety precautions in the next section and conduct a visual inspection of the unit.

### 4.1 Safety First!

To avoid risking electric shock, turn off and unplug the D-75 from the AC power outlet before attempting to disassemble or reassemble it.

If the unit has been in recent use, the large power supply capacitors will probably have enough power stored within them to present a shock hazard to you and the amplifier circuitry. To safely discharge them, place a 10 ohm, 5 watt resistor across the + and - terminals of each capacitor for several seconds. Use caution when handling the discharge resistor—particularly avoiding skin contact with the leads while discharging the capacitors.

Avoid risk of fire hazard from shorted power supplies by plugging the defective amplifier into an AC outlet which has a 15 amp circuit breaker.

### 4.2 Inspection

A careful visual inspection is valuable for most problems which you may encounter. To inspect the amplifier, remove the cover panels as described in section 4.3.1

Begin the inspection by looking for anything which appears abnormal, like broken wires and burnt or visibly damaged components. Check wire and component solder joints. Inspect the printed circuit board(s) for broken traces and loose connections. Be thorough— the time you spend visually inspecting the amp is time well spent.

### 4.3 Disassembly

The extent of disassembly required will depend upon the extent of inspection, service, testing, adjustment and repair to be performed. Illustrations referred to in parenthesis are located in the parts list (Section 9) of this manual.

#### 4.3.1. Cover Removal

A fairly complete visual inspection can be performed by removing the top (91) and bottom (90) covers. To

remove these parts, proceed as follows:

1. Remove the eight (four per side) phillips head mounting screws that secure top cover (91). Gently lift cover up and remove.
2. Remove the nine phillips head mounting screws that secure bottom cover (90). Cover will easily be removable upon screw extraction.
3. Remove each rack ear (93) for easier access to front panel components.

#### 4.3.2. Main Board Removal

The D-75 has been specially designed for ease of service. Probably the best example of this is the modular layout of the Main Board. Note that all connections are made through either push-on terminals or through two 9 pin arrays (with the exception of one ground wire which is soldered).

To remove the Main Board proceed as follows:

1. Refer to the component side board layout, Fig. 6.7.
2. Unsolder and remove the black wire marked "ground".
3. Disconnect the 15 color-coded push-on wires located throughout the underside of the main board. Their locations are marked by wire color.
4. Remove the four mounting screws and nylon spacers (33) located on the top side of the board. Gently rock the board up and down until it becomes free.
5. All work needed on this board may now be performed effortlessly.

#### 4.3.3. Output Module Replacement/Repair

The D-75 Output Module should not have to be removed unless the board itself is faulty and needs replacing. If this is the case, refer to the disassembly instructions listed below. All other components on or around the Output Module may be replaced without actual removal of the board. This procedure is also listed below, after the disassembly instructions.

##### 1. Replacement

- a. Remove the Main Board (See Main Board Removal).
- b. Unsolder and remove the four Output transistors (25) by unscrewing the 8 mounting screws (two on each). Note: In order to ease replacement of spacers located beneath each screw/nut combination, leave the D-75 in its normal lying position—flat!!
- c. Remove the four driver transistors (24) screws.
- d. Gently lift board upward, being careful not to jar the position of spacers located beneath.
- e. Remove all external wiring to Output Module and note location for future re-connection.
- f. Replace board.

## 2. Repair

a. All component parts located on the Output Module may be removed by applying standard soldering/desoldering methods (See Section 7) from the top of the board. Use extra care when working with a part located near the front panel so as not to mar the finish.

b. Front panel controls and LED's may be replaced without removing the Output Module Board (See the following section).

3. Output transistor replacement-Output transistor (25) can be replaced by removing two mounting screws (per output) and unsoldering the two main connecting pins. Note as per exploded view drawing insulating wafer (TO-3, 21), and its position in assembly.

### 4.3.4. Front Panel Parts Replacement

As previously stated, all front panel component parts can be replaced **without Output Module** removal. Generally, this operation is performed by unsoldering all or part of obstructing components. A detailed instruction format is listed below.

1. **Input level control** removal is accomplished by removing the aluminum knobs (28) and related hardware (20). Channel one pot can be pulled back and slid out the left-hand side when the headphone jack (15) and associated hardware is removed (10, 14) (rack ear (93) should be removed). Channel two input level potentiometer can be removed after the "right" lead of R232 is disconnected and the grounding bus strip is moved away from the working area. The potentiometer may need considerable, but gentle pressure in order for it to come free.

2. **IOC, Signal LED Replacement.** When handling any one of the four panel LED's (22, 23), extreme care is necessary in order to achieve a successful repair. Unsolder leads of LED to be replaced. With a pair of needle-nose pliers, remove the black support ring located behind the LED. Next carefully extract the faulty LED by pulling straight back and removing from the rear. Replace the LED and reverse of above. Note: When installing an LED always observe correct polarity! It may be helpful when inserting the rear black support ring to apply pressure with a 1/4" nut driver allowing the leads to move up the middle of the driver (See Fig. 7.17).

3. **On/Off Switch Replacement.** To replace the front panel on/off switch (35) remove aluminum knob and related hardware (27, 2, 10, 11). With a small flat-head screwdriver, slowly pry off fuse block holder from adhesive. Push switch back until solder lugs are exposed. Remove wire, and slide the switch to the right and out the end. Replacement is the reverse of above. Note: It may be necessary to replace the adhesive strip located beneath the

fuse block.

4. **Neon "Off-On" Indicator Replacement.** Because of the special mounting procedure used with the front panel power indicator (42), Crown recommends factory replacement only.

### 4.3.5. Back Panel Parts Replacement

All component parts located on the back panel of the D-75 can be replaced with relatively little effort (see exploded view drawing, rear panel assembly). Should questions arise contact the Crown Technical Service Department.

## 4.4 Reassembly

Reassembly is essentially the reverse of disassembly. If in doubt about types and sizes of attaching parts, refer to the appropriate illustration in Section 9

## 4.5. Troubleshooting

The three steps to effective troubleshooting and repair were mentioned earlier. They can be summarized in the three following questions: What is the problem (effect)? What is causing the problem (cause)? What can be done to eliminate the cause (repair)? The purpose of this section is to help you answer these questions in an orderly manner.

Finding and fixing the problem(s) is not the end of maintenance. The final step is to thoroughly test the amplifier to be certain that it meets the factory specifications after it has been repaired. The test procedures in section 4.5.3 will help you do this as well as aid you in locating the cause of problem(s).

### 4.5.1 Identifying Symptoms

Why was the amplifier brought in for repair? Can you get it to malfunction again? (Some problems can be intermittent and difficult to find.) If you don't observe anything wrong with the amplifier, tactfully inquire how the owner used it and try to determine if it was misused or some other component in their system could have been at fault. (Appendices A and B contain the installation and operation instructions for the D-75.)

If you lack sufficient information about the problem and there isn't anything obvious wrong skip to the next section and proceed directly to the test procedures in section 4.5.2. Using it can determine if the amplifier meets factory specs. If you have any questions regarding warranty coverage, please call Crown's Technical Service Department.

4.5.2 Test Procedures

Test or Adjustment	Input Signal Characteristics	Instructions/Comments
1. Quiescent DC offset	None	±10mV
2. Bias adjustment	None	Positive output, base-emitter junction should be between .3V and .35V. Adjustable by R112, R212.
3. Power (single channel)	1 volt; 1KHz sine wave	Into 8 ohms, 20 vrms (50 watts) should be obtainable before signal clip. Into 4 ohms, 17.5 vrms (75 watts) should be obtainable before signal clip.
4. Protection Circuit	1 volt; 1KHz sine wave	Into 2 ohms, signal will appear as in Figure 4.1.
5. High Frequency	1 volt; 10KHz sq. wave 1 volt; 1KHz sq. wave	Into an 8 ohm load, a 25 volt peak to peak square wave signal should exhibit no ringing (see figure 4.2) Into an 8 ohm load, a 19vrms sine wave signal should exhibit no ringing (see Figure 4.3).

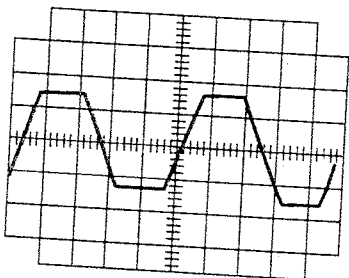

Fig. 4.1 2 Ohm Load Waveform

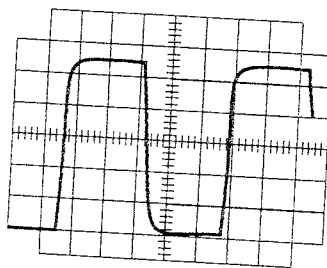

Fig. 4.2 10KHz Sq. Wave

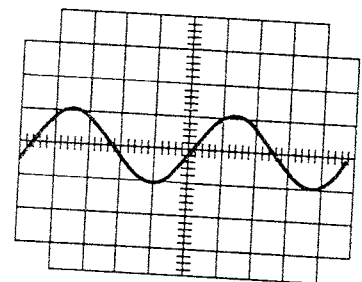

Fig. 4.3 20KHz Sine Wave

Test or Adjustment	Input Signal Characteristics	Instructions/Comments
6. Intermodulation Distortion	.5V +/-2%; 60Hz-7KHz signal summed in 4:1 ratio	(See Fig. 4.4) When using the Crown IMA, typical readings will be as follows: 0dB=.004% -5dB through -25dB=.03% -30dB=.03% -35dB=.03%
7. IOC	2.5V peak-peak .5Hz sq. wave	IOC should illuminate once for every rise time and once for every fall time (twice every full cycle). Test generator rise time must be less than 1.0 microsecond.
8. Signal to Noise		(See Fig. 4.5) Signal to noise should be 106dB below rated output with meter bandwidth of 20Hz to 20KHz.
9. Quiescent AC Power		15 watts at idle as monitored by wattmeter on AC line; 120 watts at full rated output.

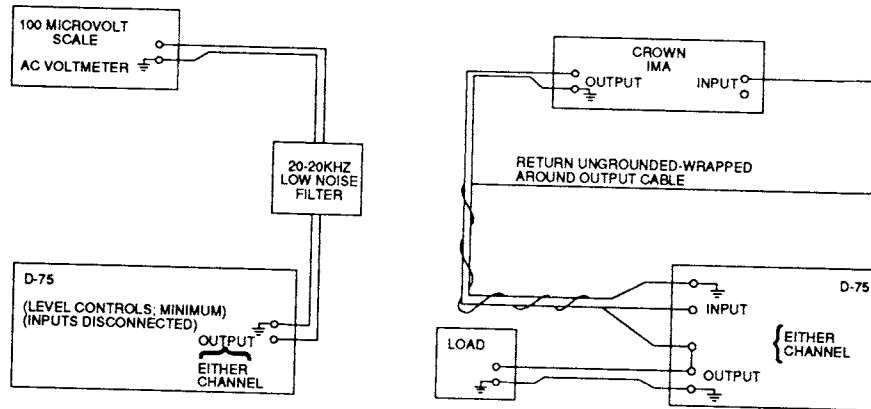

Fig. 4.4 IM Distortion Test Set-up

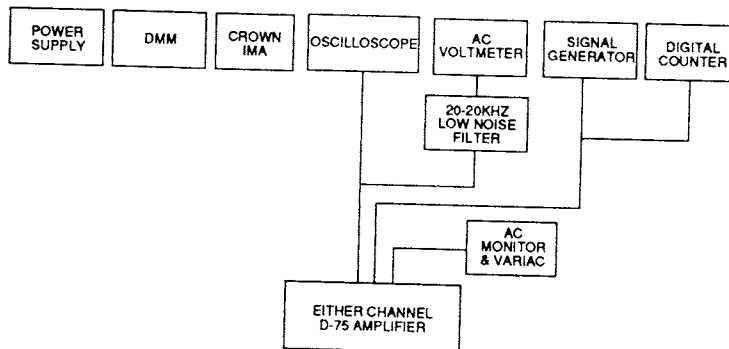

Fig. 4.5 Signal to Noise Test Set-up



## 5 Voltage Conversion

Often Crown products are purchased in one country and later moved to another requiring an AC mains conversion. For this reason the following chart/explanation as well as a world-wide voltage map is provided.

The D-75 power supply may be connected for any of five voltages. Converting from one to another can be accomplished with a soldering iron and a pair of wire cutters. Follow the table shown with the schematic, and the drawing below.

**CAUTION:** Because there is a risk of electric shock, only a competent technician should attempt to alter the line voltage configuration.

1. Remove the top cover of the D-75 (held on by 8 screws).
2. With the unit right side up, and the front panel toward you, locate the terminal strip on the front in the near right-hand corner.
3. Make the appropriate change in jumpers for the desired operating voltage. See Fig. 7.30.
4. Replace the 2 amp line fuse with a 1 amp type 3AG fuse, for all connections 200V and above.
5. Change the line cord targe to read the correct voltage.

**Note:** Use only a 2 amp fuse for 100VAC or 120VAC operation. Use only a 1 amp fuse for 200VAC, 220VAC or 240VAC operation.

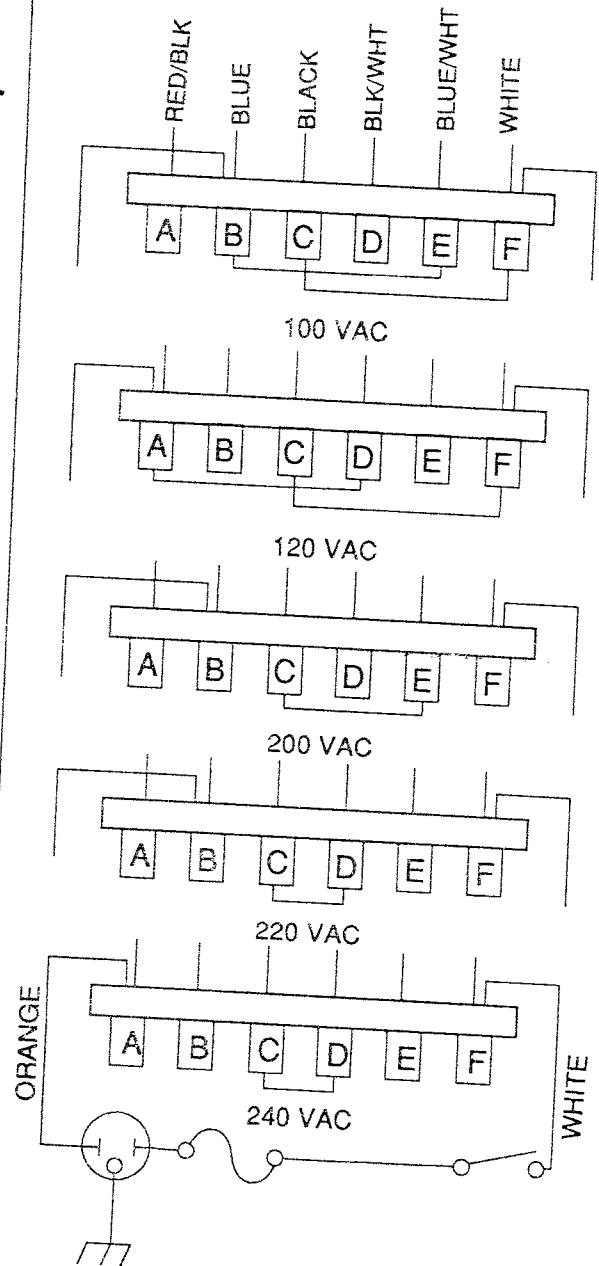

Fig. 5.1 AC Mains Voltage Conversion

**This Page Left Blank Intentionally**

# 6 Circuit Theory

## 6.1 Block Diagram Circuit Theory

The following discussion refers to the block diagram in Fig. 6.1.

When using the XLR Balanced Input, two signals, 180° out of phase, will be introduced to the Balanced Input circuitry. Here, the two signals are added together to become the Unbalanced output of the Balanced input circuitry.

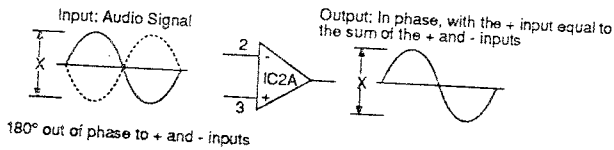

This combined signal is then fed to a stage of power amplification where it is boosted to a level of sufficient amplitude to drive an Output Load.

A portion of the output signal is routed to the Signal Presence circuitry. Provided the output signal has an amplitude of at least one volt peak to peak, the green signal presence indicators will light and vary in intensity with the output signal.

The output signal is fed back to and compared with the input signal. Any nonlinearities existing between these two signals will generate a correction signal to the amplifier and the IOC indicators on the front panel.

The Power Supply supplies the proper voltages to the various circuit components within the amplifier.

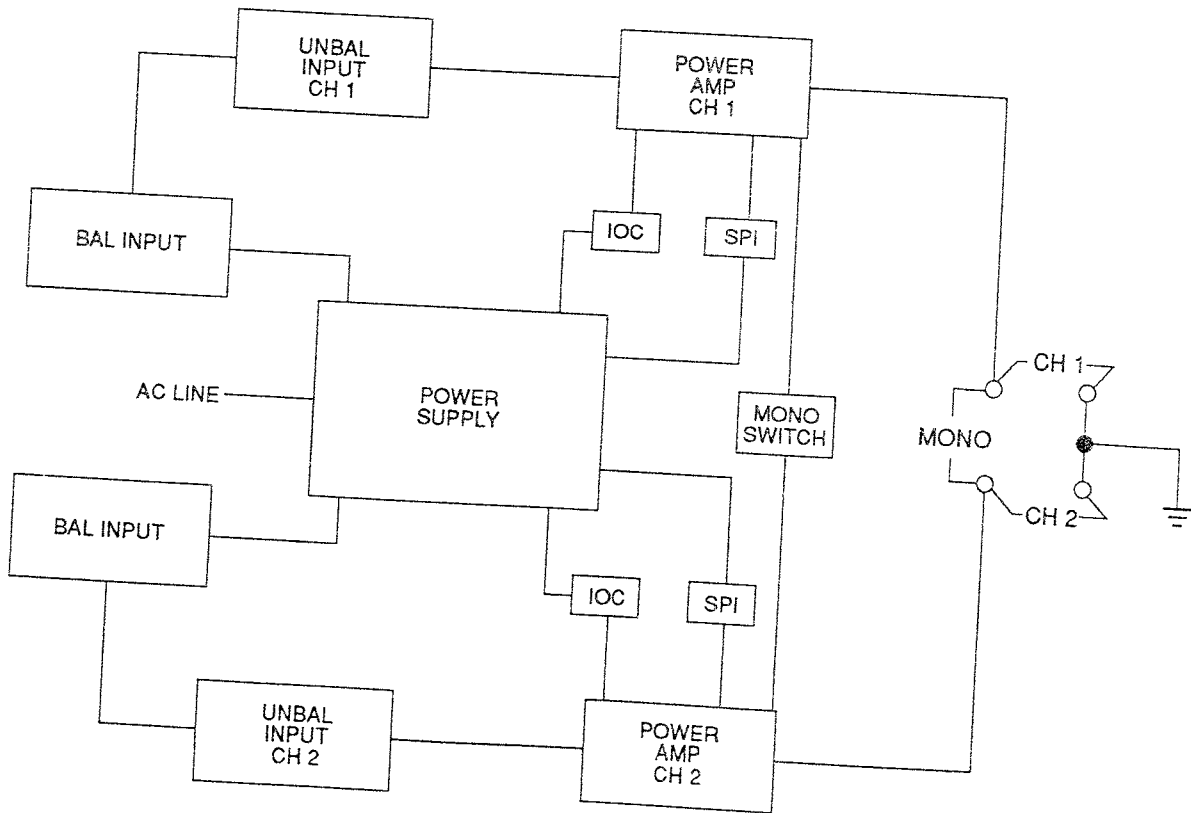

Fig. 6.1 D-75 Block Diagram

The following explanation refers to schematic diagram MI-270b located in the Instruction Manual as well as at the end of Section 9. However, each circuit under discussion is reprinted below in order to aid in circuit familiarization. Only channel 1 is shown for simplicity.

### 6.2. Balanced/Unbalanced Input Stage

In order to eliminate annoying RF interference, balanced input (as well as unbalanced) stages are incorporated in the D-75. U2A and U2B are the balanced input op amps which provide the correct phase inversion used in balanced input design. As per definition of a balanced input signal, an input from a balanced line is fed to the inverting (-) and non-inverting (+) inputs of U2A (pins 2 and 3). This has the effect of driving the inputs 180 degrees out of phase. The output signal will now be unbalanced and in phase with the signal applied to pin 3, but without any annoying noise that may have been present at the input. The reason for this is because unlike the audio input signal, the noise signal produced (by some external source) will appear on both sides of the balanced line and will cancel each other at the op amp output. Note the following diagram.

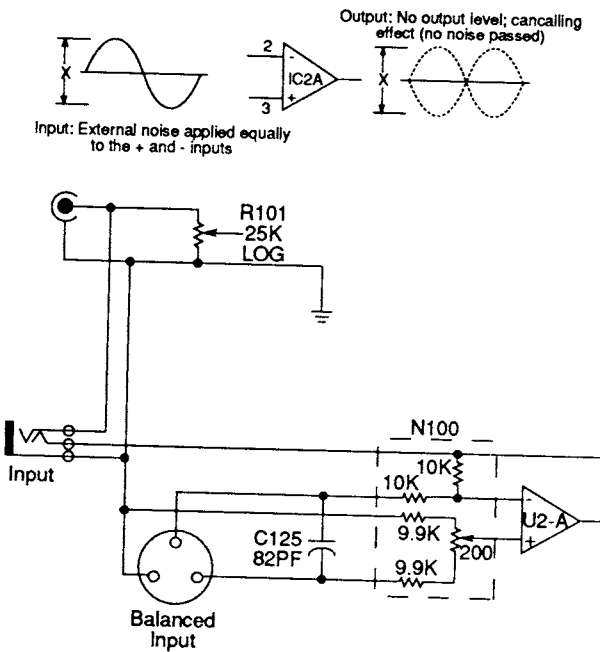

Fig. 6.2 Balanced Input Stage

### 6.3. Input Operational Amplifier

The input op amp, U100 is a low noise, large gain bandwidth integrated circuit. Under its formal name, LF

357, it acts as an input voltage amplifier producing extremely low distortion by means of several feedback paths. The gain determining components for this stage are two voltage dividing resistors, R103 and R108. Note that they act as a feedback path from the output of U100 (pin 6) to the inverting input of U100 (pin 2). Both signals entering U100 at pin 3 will be in phase with each other because of this feedback path and will thus produce an output (pin 1) of almost zero. The small amount of output signal that is present is there because of the slight difference in ohmic value (with respect to gain) of voltage divider, R108 and R103.

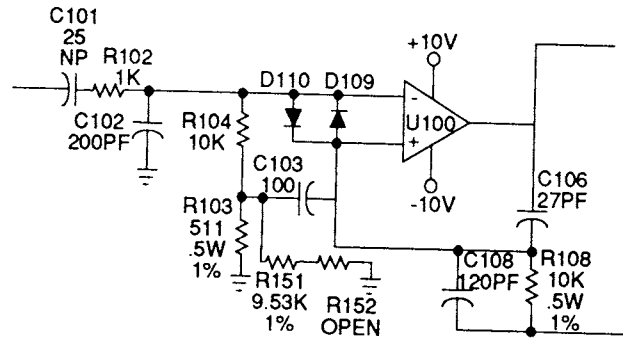

Fig. 6.3 Input Operational Amplifier

The IC op amp will always try to keep a zero potential difference between both inputs. Any type of non-linearity will cause the op amp to produce a large output, and therefore a substantial size correction signal in order to retain the small output level.

### 6.4. Signal Translator

The operation of the D-75 front-end circuitry (IC op amp through Q102) is to basically provide voltage amplification. However, the signal translator transistor (Q100) provides no voltage amplification itself, but rather converts the ground referenced input signal to a signal with a reference to the negative supply. The result is higher voltage swing capabilities from Q102 (Final Voltage Amplifier).

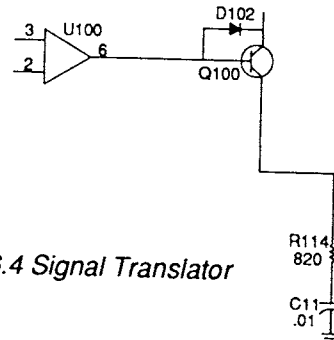

Fig. 6.4 Signal Translator

### 6.5. Final Voltage Amplifier

The Final Voltage Amplifier transistor (Q102) is the main voltage amplification stage. All signal voltage that appears at the output is developed here. R114 connected to the base circuit of Q102 serves two purposes:

- 1) it provides collector current for Q100
- 2) it provides bias voltage as well as signal for Q102

As the collector current of Q100 varies at the frequency and amplitude of the incoming signal, this same variation is placed across the Final Voltage Amplifier transistor base bias resistor and is impressed upon the base of Q102.

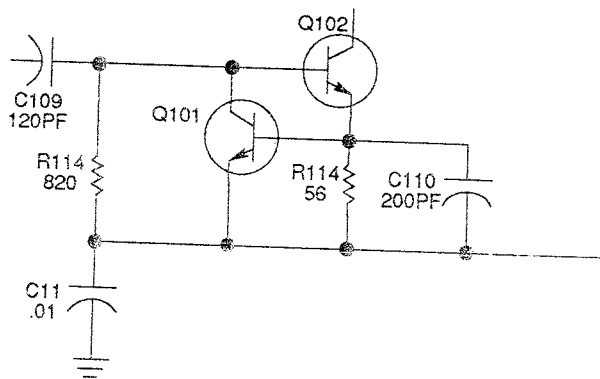

Fig. 6.5 Final Voltage Amplifier

### 6.6. Bias

The output of the Final Voltage Amplifier provides the signal drive to the predriver (Q110, Q107), driver (Q111, Q108) and output transistors (Q112, Q109) in order to amplify the current for final output power. The correct bias supply (bias transistor Q103) voltage of 2.1V DC is distributed throughout the current amplification stages in the following manner:

- 1) Base to Emitter junction of Q107 positive predriver (Q107) is .6V
- 2) Base to Emitter junction of Q108 positive driver is .6V (negative driver Q111 and output transistor Q112 have fixed base emitter bias)
- 3) Base to Emitter junction of Q109, positive output transistor is .314V (biased to sub turn-on state).

As the amplifier under loaded operating conditions increases in temperature, the bias sensing transistor (Q103) temperature increases proportionally. This condition reduces the base to emitter bias voltage produced by the bias supply which results in prevention of thermal runaway.

### 6.7. Output Stage

There are several categories or classes in which amplifiers are placed, the most common being class A, B or C. Each class or combination thereof, has a specific amount of bias current applied to the transistor which determines its operating conditions. A class A amplifier, will be biased such that a transistor operates always in the active region (360 degrees) between saturation and cutoff. A class B amplifier is biased at cutoff (180 degrees) and Class C below cutoff. The D-75 output stage is designed in Class AB+B mode of operation where the driver transistors (Q108, Q111) carry the bias current while the output transistors (Q109, Q112) serve only as boosters. The output transistors sense when the driver transistors are developing significant current draw from the load and thus take over and deliver the needed current.

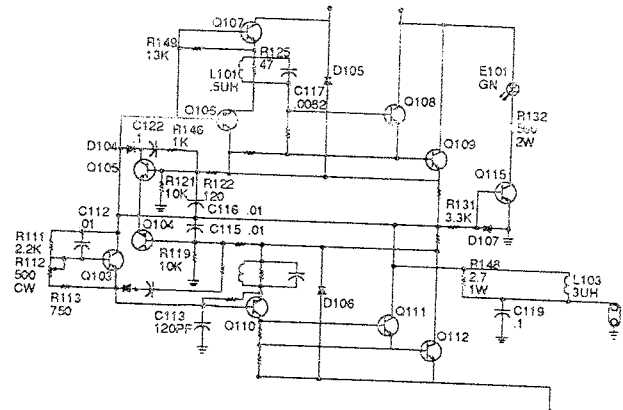

Fig. 6.6 Bias, Output and Protection Stages

The output stage is of a quasi-complementary format using no bias current into the output transistors themselves. The result is maximum efficiency with minimum crossover notch distortion and idling amplifier heat. Also, note that there is no bias current adjustment, as the output stage is not temperature-tolerance critical.

### 6.8. Protection Circuitry

The D-75 utilizes Voltage-Current limiting for protecting the output stages. V-I limiting is superior to most other forms of protection because it directly senses the overload condition and instantly reacts to relieve the overload, and acts only as long as the overload exists.

Should the output become dangerously high, the voltage induced in the current limiting sense resistors (R128, R129) is fed to the limiting transistors (Q104, Q105). The protection circuitry will then "clamp" a limit on the signal whenever it threatens to push the output stage beyond its

capabilities. The limit point is determined by a combination of the predriver plus limiter current equaling the available current source on the main board. In other words, the signal drive that is fed to the predrivers is limited or clamped.

### 6.9 IOC™

The front-panel IOC display is actually a window comparator circuit using two operational amplifiers (IC3C,D) and an LED indicator (E 102).

Any small nonlinearity in the amplifier causes an error in the feedback loop to appear at the inverted input of the main IC op amp (U100). This means the main IC output (pin 6) will rise above its normal value in an attempt to correct the problem. This signal is then responsible for raising the bias voltage on IC3 and intum activating Q114 which illuminates E 102.

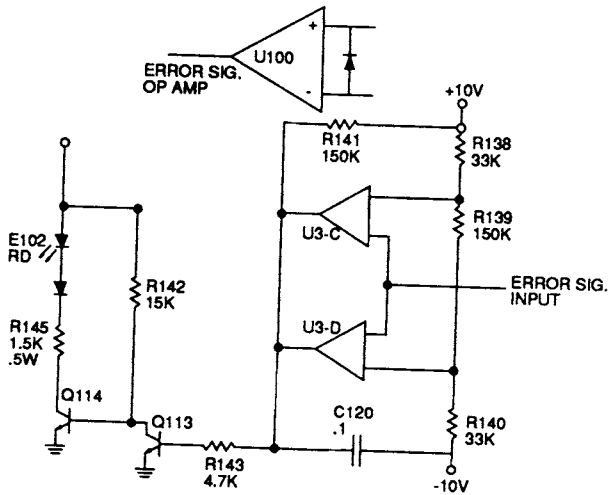

Fig. 6.7 IOC

### 6.10. Signal Presence Indicator

E 101 is the green front panel indicator which illuminates at any time the output voltage reaches 1 volt peak-peak or above. R131, R132, D107 and Q115 are the components directly involved in the above mentioned process.

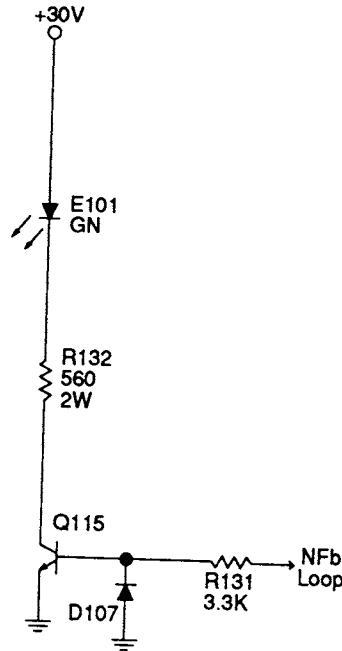

Fig. 6.8 Signal Presence Indicator

## 7. Specifications

### 7.1 General Specifications

**Hum and Noise:** From 20Hz-20KHz the hum and noise level is below 175 microvolts and 106dB below the rated output.

**Phase Response:** +10 degrees, -15 degrees 20Hz-20KHz at 1 watt.

**Input Impedance:** (XLR balanced) 20,000 ohms  $\pm$  30%, (XLR unbalanced) 10,000 ohms  $\pm$  30%, (phone jack unbalanced) 25,000 ohms  $\pm$  30%.

**Amplifier Output Protection:** Total protection against shorted, mismatched or open outputs. Volt-Ampere limiting circuitry acts instantaneously with no annoying thumps or cutouts.

**Overall Protection:** AC line fused. The controlled slewing rate of the voltage amplifiers protects the overall amplifier against RF burnout. Input overload protection is furnished by an internal resistance at the amplifier's inputs.

**DC Output Offset:** (shorted input)  $\pm$  10 millivolts.

**Turn On:** Instantaneous, with minimum bass thumps and no program delay.

**Circuit:** A total of 42 transistors, 18 signal diodes, 2 zener diodes, 4 rectifiers and 3 linear IC's (dual op-amp) are utilized in a wideband multiple feedback loop design.

**Power Supply:** A specially designed low profile transformer, two regulated supplies for complete isolation and stability plus computer grade filter capacitors serve to power the D-75.

**Power Requirements:** AC voltages of 100, 120, 200, 220, and 240 volts  $\pm$  10% at a line-frequency between 50 and 400Hz may be used.

**Power Consumption:** 15 watts while at idle, 120 watts at the full rated output.

**Heat Sinking:** The entire amplifier is used as a heat sink. Front-panel extrusion acts as a heat sink along with the chassis covers.

**Chassis:** Aluminum-chassis construction for maximum

heat conduction and minimum weight.

**Controls:** Two input-level controls and a power switch on the front panel. A mono-stereo switch, located next to the input jacks, on the rear panel.

**Indicators:** 2 IOC indicators (red), 2 Signal-Presence indicators (green), 1 Power indicator (amber).

**Connectors, Input:** XLR 3 pin audio connector in which pin 2 is positive. (for a positive output signal), or 1/4" phone jack.

**Ground Link:** A means for isolating or uniting chassis-ground from or with electrical ground is provided on the rear panel. The grounds are always connected internally by 2.7 ohms.

**Outputs:** Color-coded binding posts with a 1/4" stereo earphone jack on the front panel.

**Dimensions:** 19" (48.26cm) long, 9" (22.86cm) deep, and 1 3/4" (4.45cm) high, 8 1/2" (21.59cm) deep from mounting surface. A 19" Western Electric standard rack-mounting system is utilized.

**Weight:** 10 pounds (4.54Kg) net weight.

**Finish:** Satinized aluminum front panel with grey suede Lexan insert.

### 7.2 Monaural Specifications

**Output Power (8 ohms):** 95 watts minimum RMS into an 8 ohm load over a bandwidth of 20Hz-20KHz at a rated RMS sum total harmonic distortion of 0.05% of the fundamental output voltage.

**Output Power (16 ohms):** 70 watts minimum RMS into an 16 ohm load over a bandwidth of 20Hz-20KHz at a rated RMS sum total harmonic distortion of 0.05% of the fundamental output voltage.

**Frequency Response:**  $\pm$  0.2dB 20Hz-20KHz, 1 watt, 8 ohms.

**1KHz Power:** 80 watts RMS into 16 ohms; 110 watts RMS into 8 ohms, (0.1% Total Harmonic Distortion).

**I.M. Distortion:** Less than 0.05% from 0.01 watts to 0.25 watts, and less than 0.01% from 0.25 watts to 70 watts into 16 ohms.

**Slewing Rate:** 12 volts per microsecond.

**Damping Factor:** Greater than 400, DC-400Hz into 16 ohms.

**Output Impedance:** Less than 30 milliohms in series with less than 6 microhenries.

**Load Impedance:** Rated for 8 and 16 ohm usage, safely drives any load including completely reactive loads.

**Voltage Gain:**  $41.2 \pm 2\%$  (or  $32.3 \pm 0.2\text{dB}$ ) at maximum gain.

**Input Sensitivity:** .812 volts  $\pm 2\%$  for 95 watts into 8 ohms.

**Output Signal:** Balanced, single channel. Channel 1 controls are active, Channel 2 is inactive, but not disabled.

### 7.3 Stereo Specifications

**Output Power (4 ohms):** 45 watts per channel minimum RMS (both channels operating) into a 4 ohm load over a bandwidth of 20Hz-20KHz at a rated RMS sum total harmonic distortion of 0.05% of the fundamental output voltage.

**Output Power (8 ohms):** 35 watts per channel minimum RMS (both channels operating) into an 8 ohm load over a bandwidth of 20Hz-20KHz at a rated RMS sum total harmonic distortion of .05% of the fundamental output

voltage.

**Frequency Response:**  $\pm 0.1\text{dB}$  20Hz-20KHz at 1 watt into 8 ohms;  $\pm 1.2\text{dB}$  5Hz-100KHz at 1 watt into 8 ohms.

**1KHz Power:** 40 watts RMS into 8 ohms per channel, both channels operating; 0.1% total harmonic distortion; 55 watts RMS into 4 ohms, per channel, both channels operating, 0.1% total harmonic distortion.

**I.M. Distortion (60Hz-7KHz 4:1):** Less than 0.05% from 0.01 watts to 0.25 watts, and less than 0.01% from 0.25 watts to 35 watts into 8 ohms per channel.

**Slewing Rate:** 6 volts per microsecond.

**Damping Factor:** Greater than 400, DC-400Hz into 8 ohms.

**Output Impedance:** Less than 15 milliohms in series with less than 3 microhenries.

**Load Impedance:** Rated for 8 and 4 ohm usage; safely drives any load including completely reactive loads.

**Voltage Gain:**  $20.6 \pm 2\%$  or  $26.3 \pm 0.2\text{dB}$  at maximum gain.

**Input Sensitivity:** 0.812 volts  $\pm 2\%$  for 35 watts into 8 ohms.

**Output Signal:** Unbalanced, dual channel.



Configuration & Load per Ohm	Type of Test	FTC Continuous Average Power at >1% THD (See note 1)		Single Cycle Tone Burst Watts at <0.05% THD (See note 2)	40mS Tone Burst Watts at <0.05% THD (See note 3)	EIA Watts +/-1dB 1% THD (See note 4)
		20Hz-20KHz	1KHz	1KHz	1KHz	1KHz
Stereo per CH. (both ch. powered)	4	45	55	115	70	55
	8	35	40	60	45	40
	16	25	25	30	25	25
Bridged Monaural (Balanced Output)	8	95	110	135	105	
	16	70	80	130	90	75

Fig. 7.1 Power Matrix

### Power Specifications

Many manufacturers publish power specifications with a tolerance of  $\pm 1$  dB or worse. That means their amplifier can deviate more than 20% in output! A 100 watt amp would meet their spec if it only produced 79.4 watts. Other manufacturers qualify their specs by saying they are "typical" or "subject to manufacturing tolerances," thereby removing any performance guarantee. We take a different approach at Crown - our published specifications are *guaranteed* for three years and can be protected with *Service Plus* for an additional 3 years. Further, because our "in-house" specs are more stringent than our published specs, every Crown amplifier will exceed its published specs. We believe you should get what you pay for.

### Notes:

1. Continuous power in the context of Federal Trade Commission testing is understood to be a minimum of five minutes of operation. Harmonic distortion is measured at the RMS sum total as a percentage of the fundamental output voltage. This applies for all wattages greater than 0.25 watts.
2. A single cycle of sine wave is presented to the amplifier and monitored for non-linear distortion. The average power during the burst is reported. Speakers must be able to withstand this level if they are to be safely used with this amplifier.
3. A 40 millisecond burst or two cycles of sine wave (whichever is of greater duration) is used and the power computed as the average power during the burst. The duty cycle of this test is 10 percent. This power level is a measure of how loud an amplifier is as perceived by the hearing process.
4. EIA standard RS-490 (both channels driven).

7.4 Performance Graphs

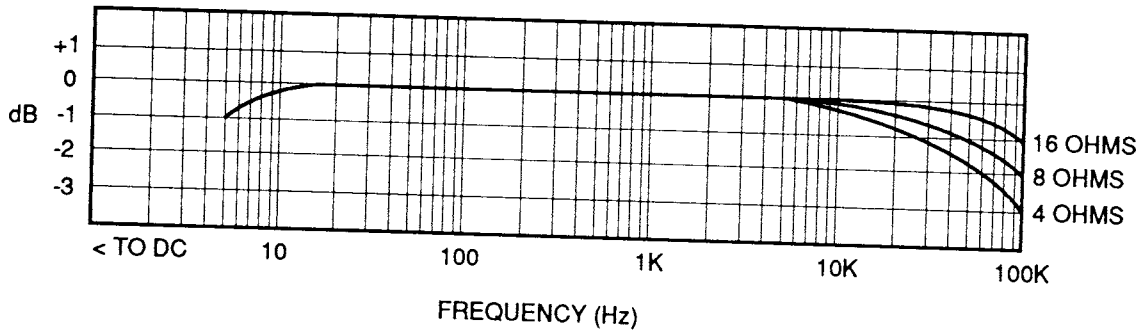

Fig. 7.2 Nominal Frequency Response

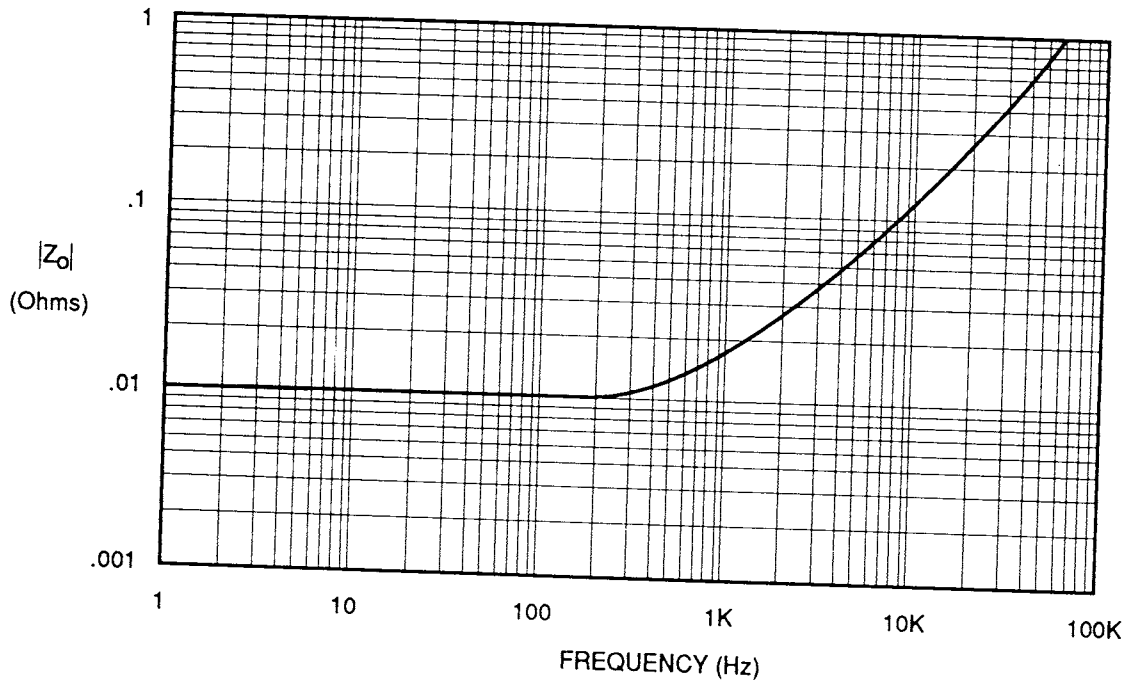

Fig. 7.3 Nominal Output Impedance ( $Z_o$ )

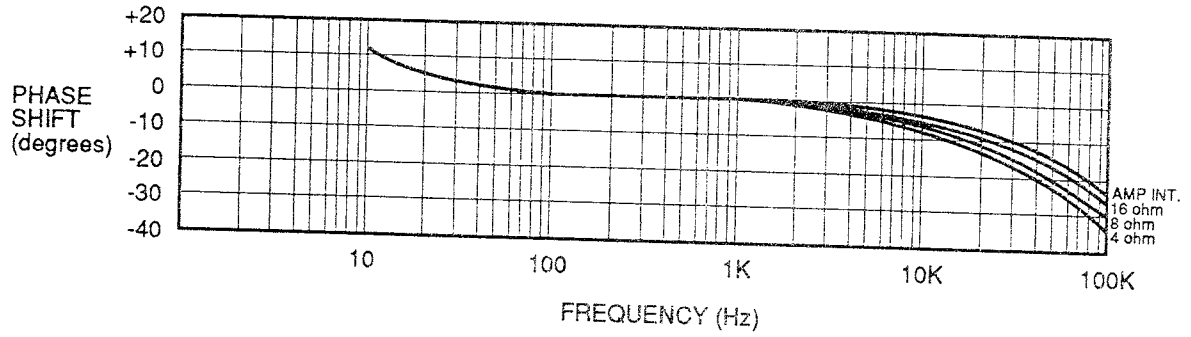

Fig. 7.4 Nominal Phase Response

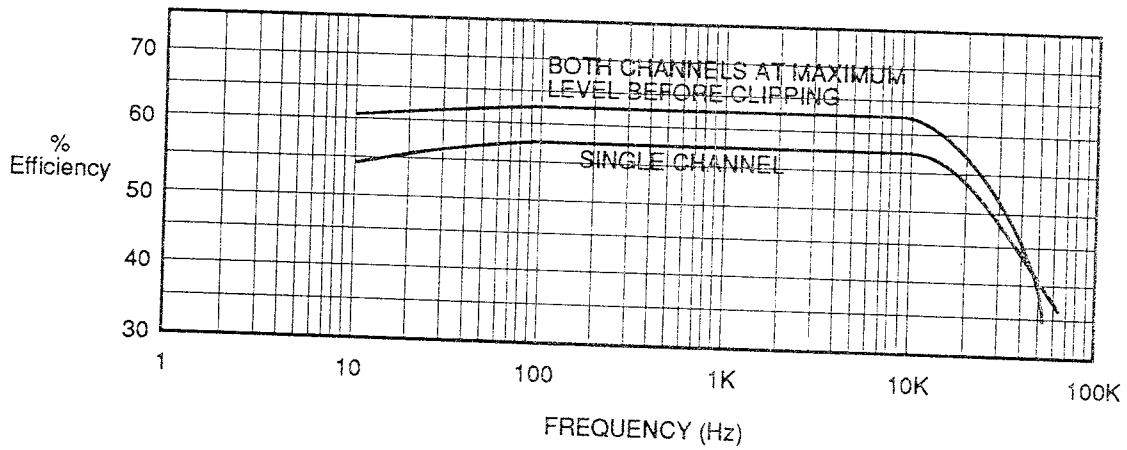

Fig. 7.5 Nominal Power Efficiency (8 ohms)

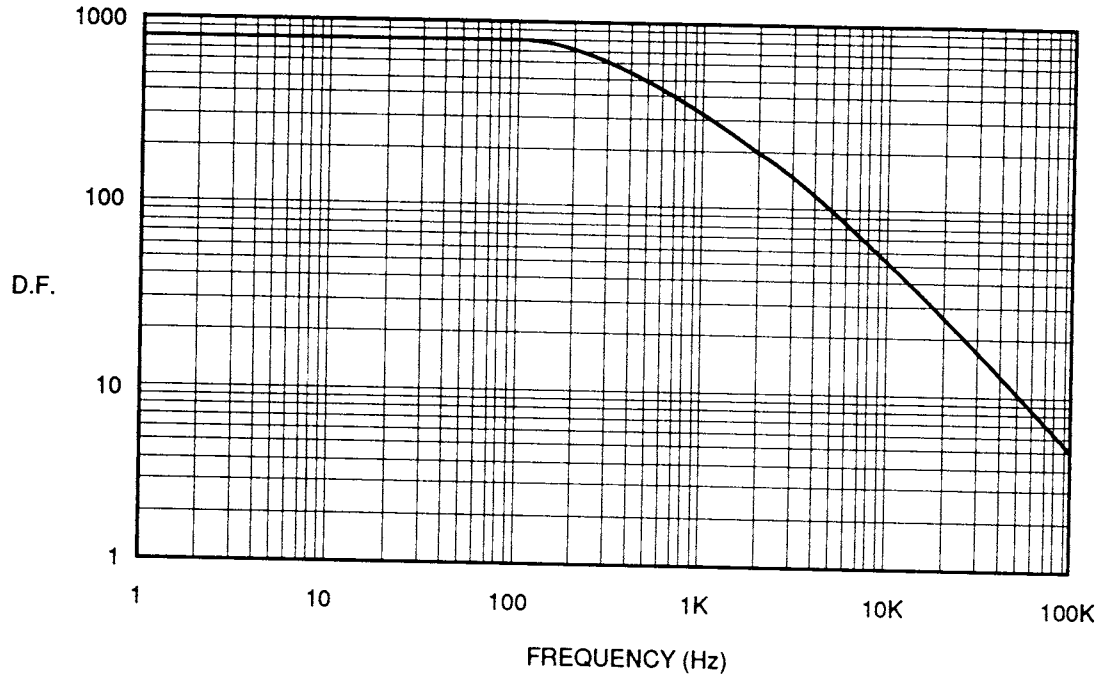

Fig. 7.6 Nominal Damping Factor

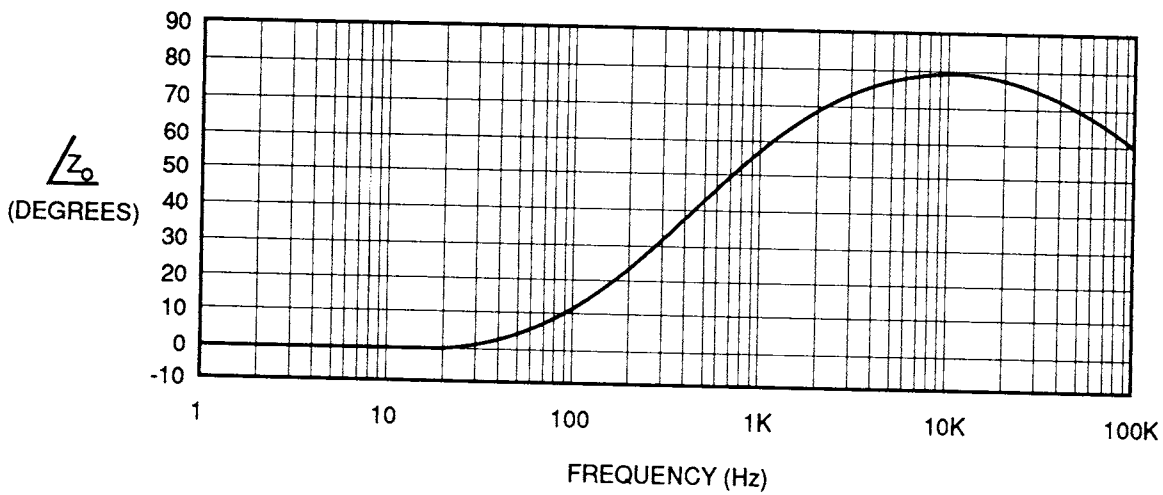

Fig. 7.7 Nominal Output Phase Angle

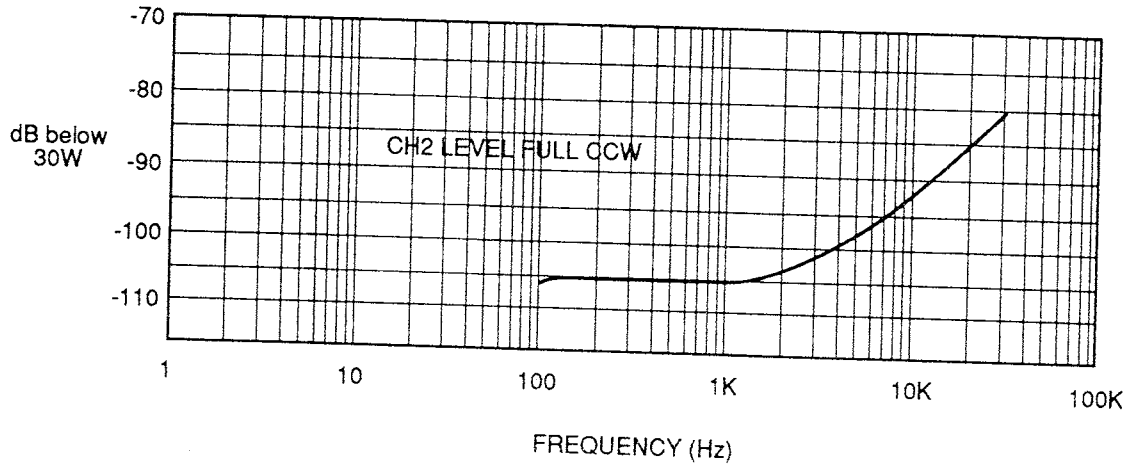

Fig. 7.8 Nominal Crosstalk

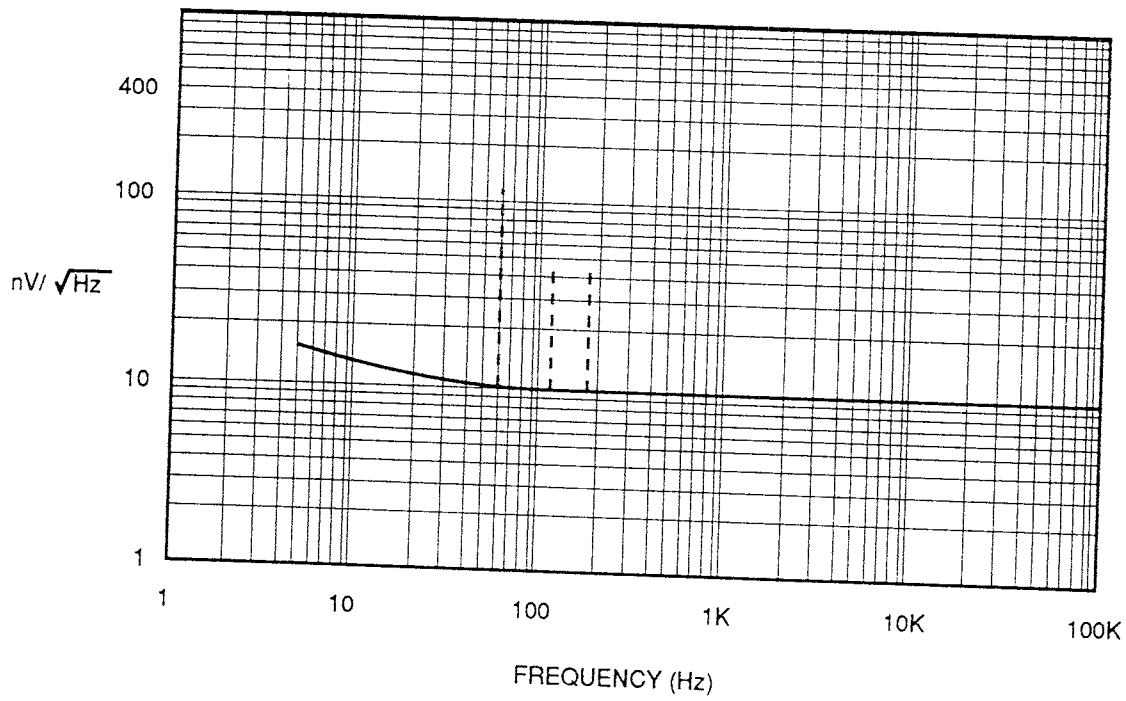

Fig. 7.9 Nominal Noise Spectrum

**This Page Left Blank Intentionally**

---

## 8 D-75 Schematic Diagrams

---

*Fig. 8.1 D-75 Schematic Diagrams*

*For Amplifier S/N 24530 and below use schematic number MI-270b  
For Amplifier S/N 24531 and above use schematic number J 0116-4*





## 9 Parts

### 9.1 General Information

Section 9 contains illustrations and parts lists for the D-75 power amplifier. This information should be used with the service, repair and adjustment procedure in Section 4.

Most of the mechanical and structural type parts are illustrated and indexed on exploded view drawings. Electrical and electronic parts on these illustrations are also identified by the circuit reference designation next to the illustration. Both the index number and the reference designation are included in the parts list in separate columns. The reference designations correspond to those shown in schematic diagrams.

Electrical and electronic parts located on printed circuit boards are illustrated by schematic symbols on the trace side and by component shape symbols on the component side. Reference designations also appear on these diagrams.

The quantity of each part used in each location is also shown in the parts listing.

### 9.2 Standard and Special Parts

Many electrical and electronic parts used in the D-75 are standard items stocked by and available from electronic supply houses. However, some electronic parts that appear to be standard, are actually special. A part

ordered from Crown will assure an acceptable replacement. Structural items, covers and panels are available from Crown only.

### 9.3 Ordering Parts

When ordering parts, be sure to give the amplifier model and serial number and include the part description and Crown Part Number (CPN) from the parts list. Price quotes are available upon request.

### 9.4 Shipment

1. Shipment will be made by UPS or best method unless you specify a preferred method.
2. Shipments are made F.O.B. Elkhart, Indiana only.
3. Established Crown accounts will be freight prepaid and billed unless shipped by truck or air freight.
4. All others will be shipped freight collect.

### 9.5 Terms

1. Normal terms are C.O.D. unless the order is prepaid.
  2. Net 30 days terms apply only to those firms who have an established line of credit with Crown.
  3. If prepaying please add an amount for the freight charge. \$2.00 is average for an order under one pound.
- NOTE:** Part prices are subject to change without notice.
4. New parts returned for credit are subject to a 10% restocking charge.
  5. You must receive authorization from the Parts Dept. before returning parts for credit.
  6. We are not a general parts warehouse! Parts are available for servicing Crown products only.

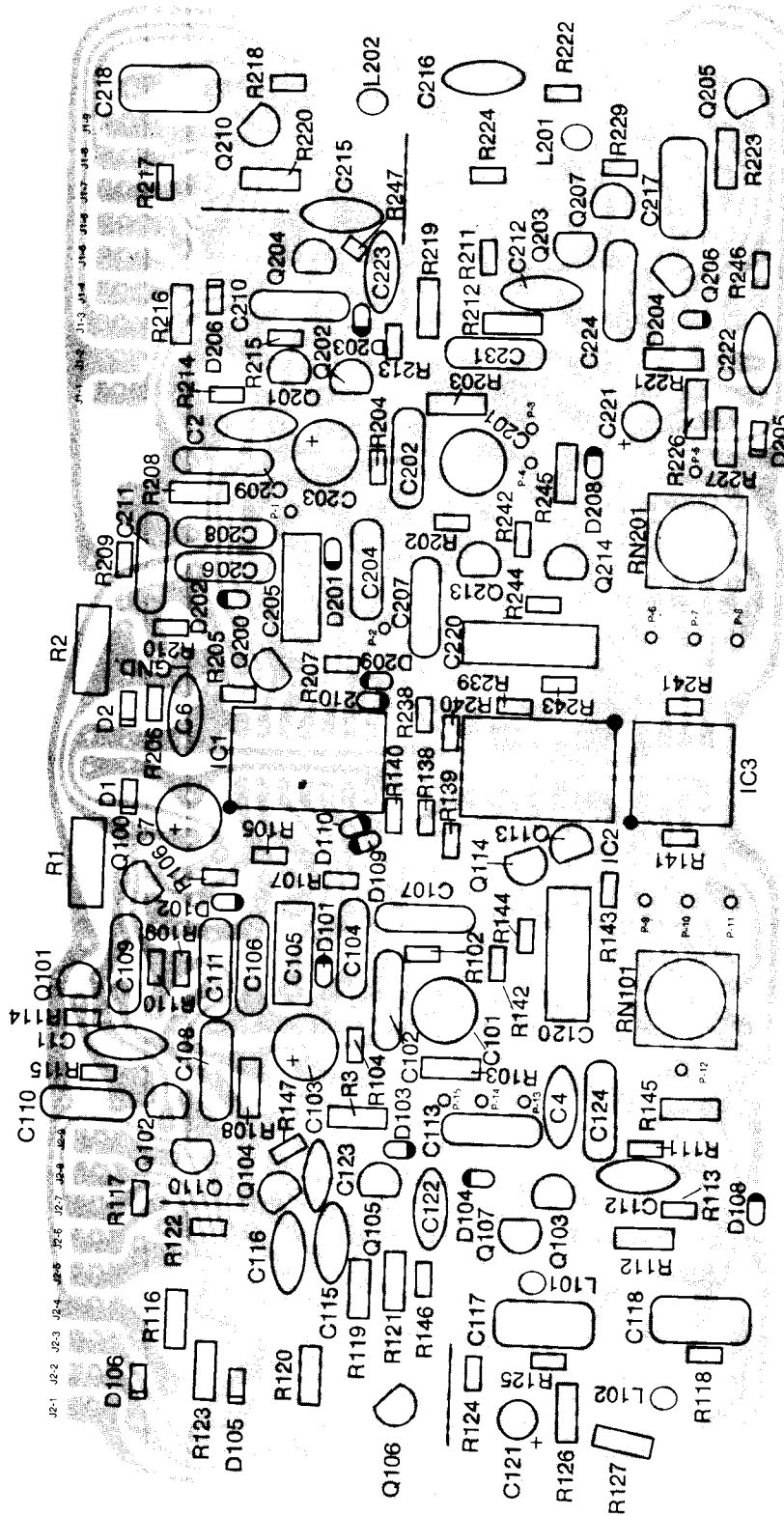
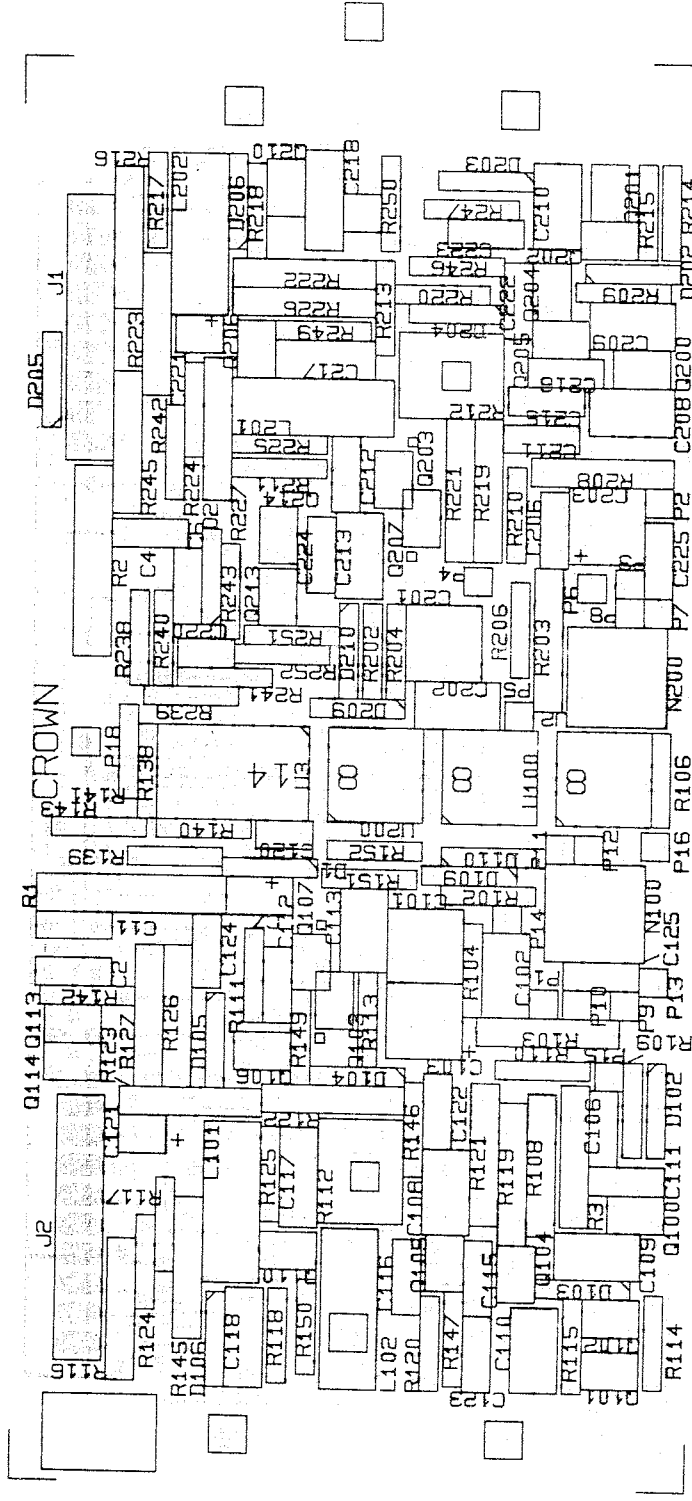

Fig. 9.1a D-75 MainModule



COMP ID A0710DS

Fig. 9.1b D-75 MainModule

**9.6 Illustrated Parts Lists**
**Parts List: D-75 Main Board Module Q41944J1**

Schematic Designation	Description	Qty.	Part No.	Misc. Info	
<b>Capacitors</b>					
C111, C211	5pf mica	2	C 2820-6		
C106, C206	27pf mica	2	C 2342-1		
C124, C224	82pf mica	2	C 3627-4		
C107, C207	100pf mica	2	C 3410-5		
C108, C208, C109, C209, C113, C213	120pf mica	6	C 3290-1		
C102, C202	200pf mica	6	C 3411-3		
C104, C204		2	C 3089-7		
C110, C210	.0015mf 200V filmatic	6	C 3411-3		
C105, C205		2	C 3089-7		
C117, C217	.0082mf 200V filmatic	4	C 3063-2		
C118, C218					
C2, C4, C6, C11	.01mf disc	14	C 1751-4		
C112, C212, C115, C215, C116, C216, C122, C222, C123, C223		2	C 3218-2		
C120, C220	.22mf 100V filmatic	2	C 3218-2		
C7	4.7mf 63V vert	1	C 4253-8		
C121, C221	10mf 50V vert	2	C 3728-0		
C101, C201	22mf 16V N-P vert	2	C 5311-3		
C103, C203	100 mf/12V vert	2	C 3729-8		
<b>Diodes</b>					
D105, D205	1N 4003	4	C 2851-1		
D106, D206					
D104, D204, D108, D208, D102, D202, D101, D201, D109, D209, D110, D210		1N4148	12	C 3181-2	
D103, D203		1N270	2	D 6212-1	
D1, D2	1N961 B 10V zener	2	C 3549-0		
<b>Integrated Circuits</b>					
U100	LF357 Op amp	1	C 6527-3		
U2	RC4558 Dual Op amp	1	C 3919-5		
U3	LM339N	1	C 4345-2		

## D-75 Main Board Module Q41944J1 Continued ...

Schematic Designation	Description	Qty.	Part No.	Misc. Info
<b>Coils</b> L101, L201, L102, L202	.5MH Axial Gm	4	C 3510-2	
<b>Transistors</b> Q101, Q201, Q103, Q203, Q105, Q205, Q113, Q213, Q114, Q214, Q102, Q202 Q107, Q207 Q104, Q204, Q106, Q206 Q100, Q200 Q110, Q210	2N3859A NPN MPSA06 NPN  2N 4125 PNP PN4250A PNP MPSA56 PNP	12 2  4 2 2	D 2961-7 C 3528-5  C 3625-8 C 3786-8 C 3954-2	
<b>Resistors</b> R115, R215 R120, R220 R118, R218 R122, R222 R117, R217, R124, R224 R125, R225, R147, R247 R103, R203 R113, R213 R114, R214 R1, R2 R107, R207, R146, R246, R102, R202 R145, R245 R111, R211 R110, R210 R126, R226, R127, R227 R116, R216, R123, R223 R104, R204 R143, R243 R106, R206 R138, R238 R140, R240 R109, R209 R139, R239 R141, R242 RN100, RN200	56 ohm 1/4w 5cf 120 ohm 1/4w 5cf 100 ohm 1/4w 5cf 120 ohm 1/2w 5cf  180 ohm 1/4W 5cf  470 ohm 1/4w 5cf 510 ohm 1/2w 1MF 750 ohm 1/4w 5cf 820 ohm 1/4w 5cf 820 ohm 1w 5 comp  1K ohm 1/4w 5cf 1.5K ohm 1/2w 5cf 2.2K ohm 1/4w 5cf 3.9K ohm 1/4w 5cf  4.7K ohm 1/2w 5cf  5.6K ohm 1/2w 5cf  10K ohm 1/4w 5cf 22K ohm 1/4w 5cf  33K ohm 1/4w 5cf 56K ohm 1/4w 5cf 150K ohm 1/4w 5cf 1M ohm 1/4w 5cf Bal. input trimmer	2 2 2 2  4  4 2 2 2 2  6 2 2 2  4  4  4 2  4 2  4 2 2 2 2 2	C 3511-0 C 4723-0 C 2872-6 C 3837-9  C 2873-5  C 2626-7 C 3304-0 C 3803-1 C 3301-6 C 3648-0  C 2627-5 C 1076-6 C 2628-3 C 2630-9  C 1640-9  C 3299-2  C 2631-7 C 3302-4  C 4346-0 C 2882-8 C 4216-5 C 3198-6 D 4669-4	

**D-75 Main Board Module Q41944J1 Continued ...**

Schematic Designation	Description	Qty.	Part No.	Misc. Info
R112, R212 R3, R108, R208, R119, R219 R121, R221 R142, R242 R105, R205, R144, R244	Selected bias resistor  10K ohm 1/2w 1MF 15K ohm 1/4w 5cf  18K ohm 1/4w 5cf	2  7 2 4	  C 2343-9 C 2632-5  C 2633-3	Typically 92-240 ohms
<b>Parts List: D-75 Main Board Module Q42530-8</b>				
<b>Capacitors</b>				
C111, C211	5pf mica	2	C 2820-6	(not in current production)
C106, C206	27pf mica	2	C 2342-1	
C124, C224 C125, C225	82pf mica	2	C 3627-4	
C108, C208, C109, C209, C113, C213	120pf mica	6	C 3290-1	
C102, C202 C110, C210 C7	200pf mica .001mf disc	4	C 3411-3	
C117, C217 C118, C218	.0082mf 200V filmatic .0027mf 200V filmatic	2 2	C 3063-2 C 3481-6	
C2, C4, C6, C11, C12, C13 C112, C212, C115, C215, C116, C216, C122, C222, C123, C223 C119, C219, C120 C220, C123, C223 C121, C221	.01mf disc  .1mf 63v ceramic 10mf 50V vert 22mf 16V N-P vert 100 mf/12V vert	14  6 2 2 2	C 1751-4  C 5639-7 C 3728-0 C 5311-3 C 3729-8	
<b>Diodes</b> D105, D205 D106, D206 D102, D202, D104, D204, D109, D209, D110, D210 D103, D203	1N 4003  1N4148 1N270	4  8 2	C 2851-1  C 3181-2 D 6212-1	

## D-75 Main Board Module Q42530-8 Continued ...

Schematic Designation	Description	Qty.	Part No.	Misc. Info
D1, D2	1N961 B 10V zener	2	C 3549-0	
<b>Integrated Circuits</b>				
U100	LF357 Op amp	2	C 7621-3	
U2	RC4558 Dual Op amp	1	C 3919-5	
U3	LM339N Volt Comparator	1	C 4345-2	
<b>Coils</b>				
L101, L201, L102, L202	.5MH Axial Gm	4	C 3510-2	
<b>Transistors</b>				
Q101, Q201, Q103, Q203, Q105, Q205, Q113, Q213, Q114, Q214, Q102, Q202	2N3859A NPN	12	D 2961-7	
Q107, Q207 Q104, Q204, Q106, Q206	MPSA06 NPN	2	C 3528-5	
Q100, Q200 Q110, Q210	2N 4125 PNP	4	C 3625-8	
	PN4250A PNP	2	C 3786-8	
	MPSA56 PNP	2	C 3954-2	
<b>Resistors</b>				
R115, R215	56 ohm 1/4w 5cf	2	C 3511-0	
R120, R220	120 ohm 1/4w 5cf	2	C 4723-0	
R118, R218	100 ohm 1/4w 5cf	2	C 2872-6	
R122, R222	120 ohm 1/2w 5cf	2	C 3837-9	
R117, R217, R124, R224	180 ohm 1/4W 5cf	4	C 2873-5	
R125, R225	47 ohm 1/4w 5 cf	2	C 1011-3	
R147, R247	470 ohm 1/4w 5% cf	2	C 2626-7	
R103, R203	510 ohm 1/2w 1MF	2	C 3304-0	
R113, R213	750 ohm 1/4w 5cf	2	C 3803-1	
R114, R214	820 ohm 1/4w 5cf	2	C 3301-6	
R1, R2	910 ohm 3w 5% cf	2	C 7389-7	
R146, R246, R102, R202	1K ohm 1/4w 5cf	6	C 2627-5	
R145, R245	1.5K ohm 1/2w 5cf	2	C 1076-6	
R111, R211	2.2K ohm 1/4w 5cf	2	C 2628-3	
R110, R210	3.9K ohm 1/4w 5cf	2	C 2630-9	
R126, R226, R127, R227	4.7K ohm 1/2w 5cf	4	C 1640-9	
R116, R216, R123, R223	5.6 ohm 1/2w 5cf	4	C 3299-2	
R104, R204	10K ohm 1/4w 5% cf	2	C2631-7	
R143, R243	4.7K ohm 1/4w 5cf	2	C 3939-3	
R106, R206	22K ohm 1/4w 5cf	2	C 3302-4	

**D-75 Main Board Module Q42530-8 Continued ...**

Schematic Designation	Description	Qty.	Part No.	Misc. Info
R138, R238				
R140, R240	33K ohm 1/4w 5cf	4	C 4346-0	
R109, R209	56K ohm 1/4w 5cf	2	C 2882-8	
R139, R239				
R141, R241	150K ohm 1/4w 5cf	4	C 4216-5	
RN100, RN200	Bal. input trimmer	2	D 4669-4	
R112, R212	500 ohm trimmer	2	C 6048-0	
R3				
R108, R208,				
R119, R219				
R121, R221	10K ohm 1/2w 1MF	7	C 2343-9	
R142, R242	15K ohm 1/4w 5cf	2	C 2632-5	
R149, R150				
R249, R250	13K 1/4w 5% cf	4	C 4300-7	
R151, R251	9.53K 1/4w 1% mf	2	C 6161-1	
R152, R252 (open)				
<b>Misc.</b>				
	D-75 Board (without parts)	1	D 6248-5	
	TO92 heatsink	1	C 3493-1	
	IC Socket (8 pin)	3	C 3451-9	
	IC Socket (14 pin)	1	C 3450-1	
	PC Mnt RCPT	18	C 4731-3	



Fig. 9.2 D-75  
Output Module

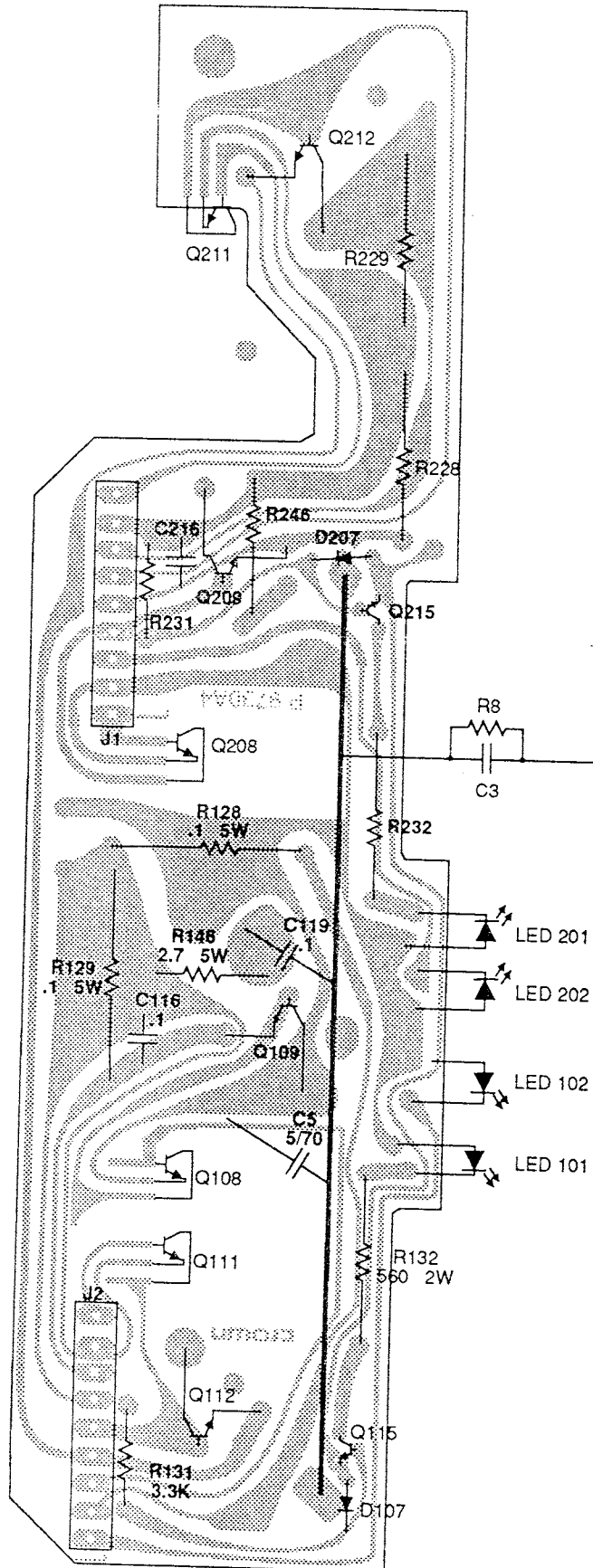

**Parts List: D-75 Output Module Q41945J8**

Schematic Designation	Description	Qty.	Part No.	Misc. Info
<b>Capacitors</b>				
C12				
C116, C216	.01mf disc	3	C 1751-4	
C119, C219	.1mf 200V Filmatic	2	C 2938-6	
C1, C5	5mf 70V	2	C 5050-7	
<b>Diodes</b>				
D107, D207	1N4148	2	C 3181-1	
<b>Transistors</b>				
Q115, Q215	2N3859A NPN	2	D 2961-7	
<b>Resistors</b>				
R8	2.7 ohm .5W 5CF	1	C 2857-8	
R148, R248	2.7 ohm 1 w 10%	2	C 1001-4	
R128, R228				
R129, R229	.1 ohm 5 w 10% wire	4	C 3291-9	
R132, R232	560 ohm 2 w 5 comp	2	C 4724-8	
R131, R231	3.3K ohm 1/2 w 5CF	2	C 1051-9	
<b>Misc.</b>				
	9 pin connector	2	C4730-5	
	D-75 Board (without parts)	1	P 9730A4	
1	Solder lug .144" hole	1	D 1220-9	Located at one corner of the output board

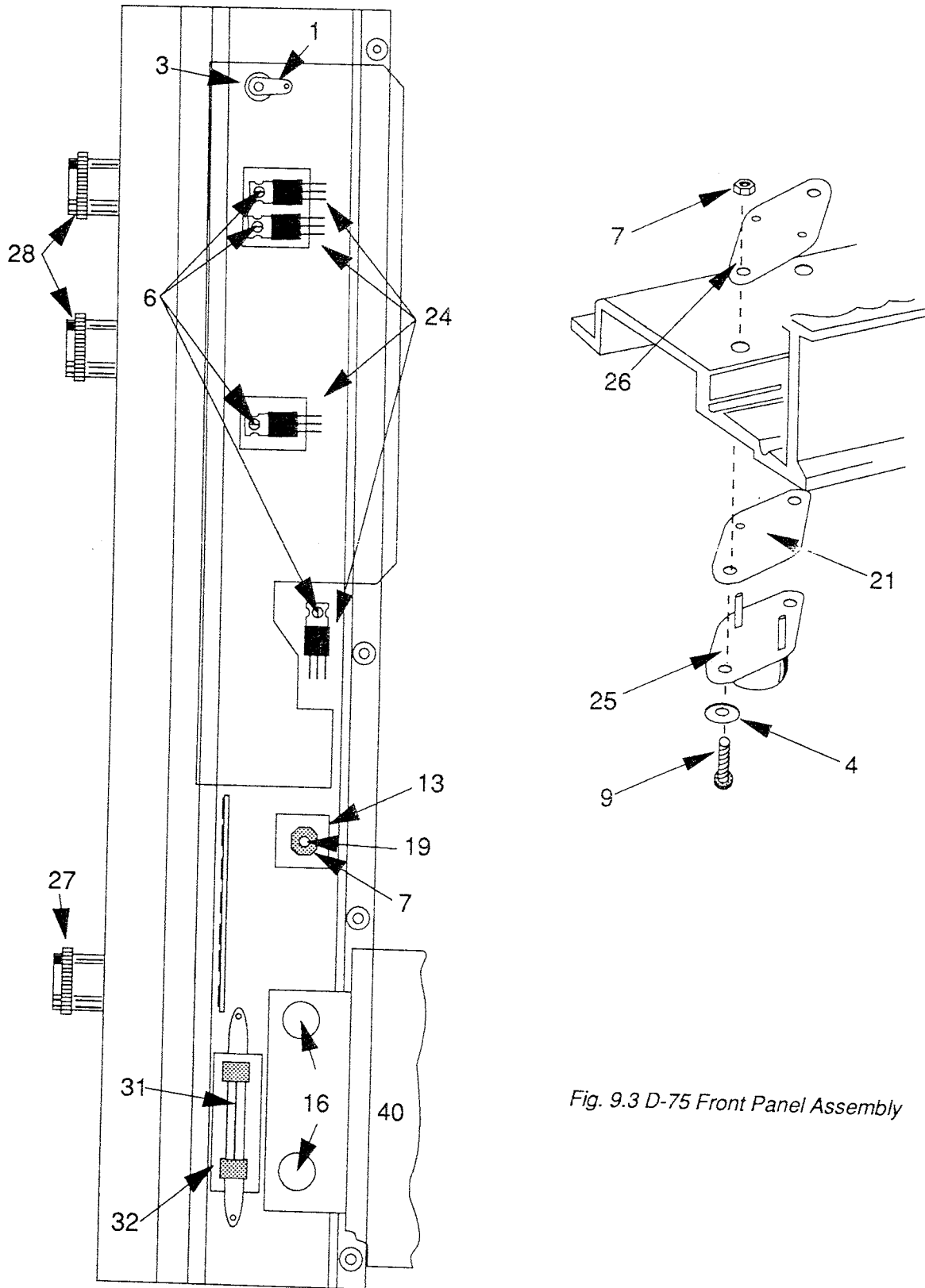

Fig. 9.3 D-75 Front Panel Assembly

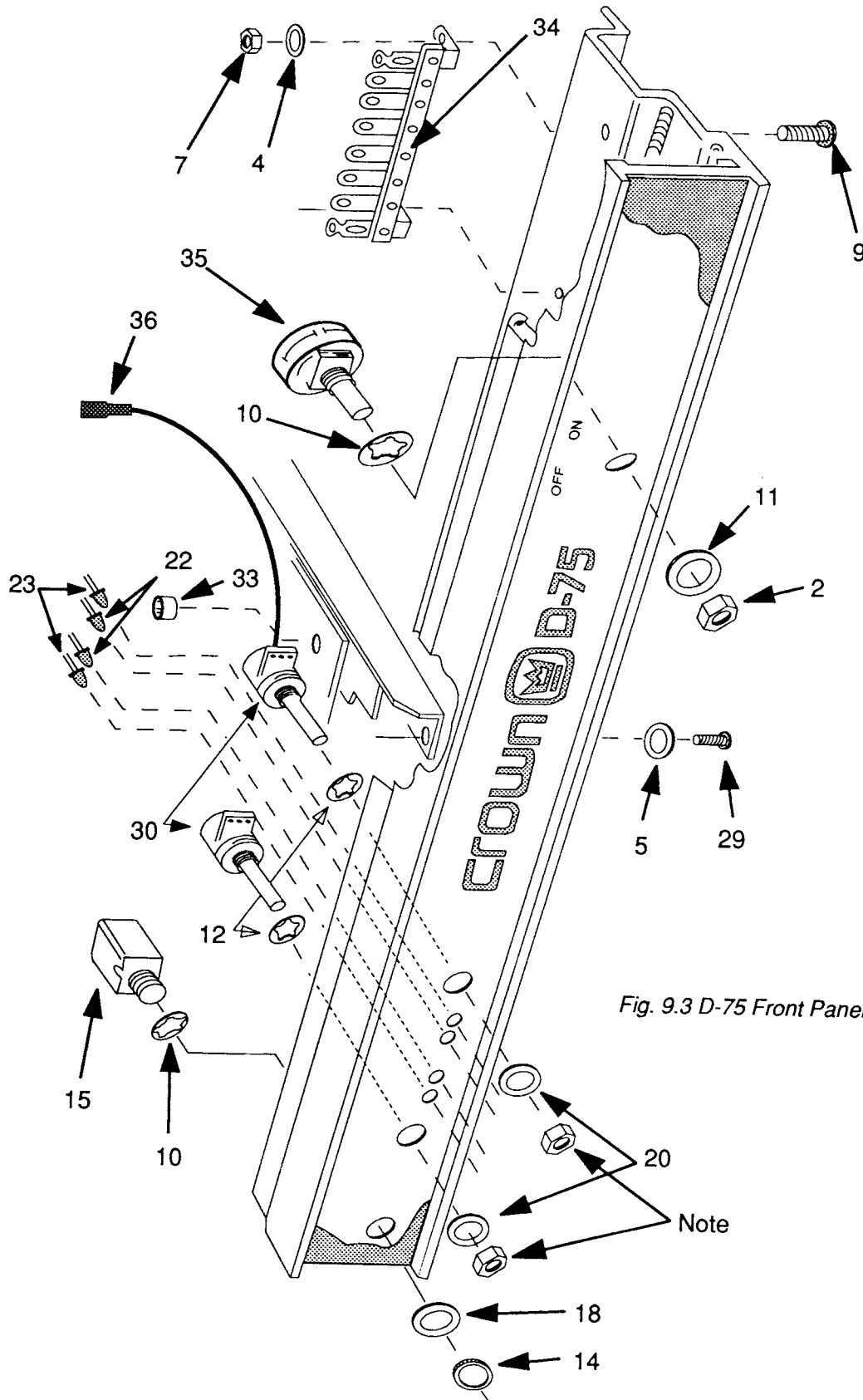

Fig. 9.3 D-75 Front Panel Assembly

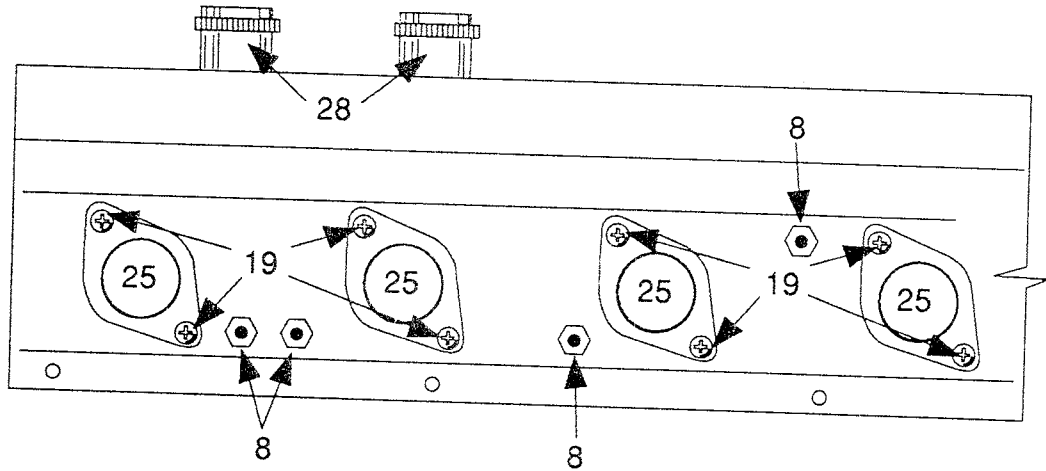
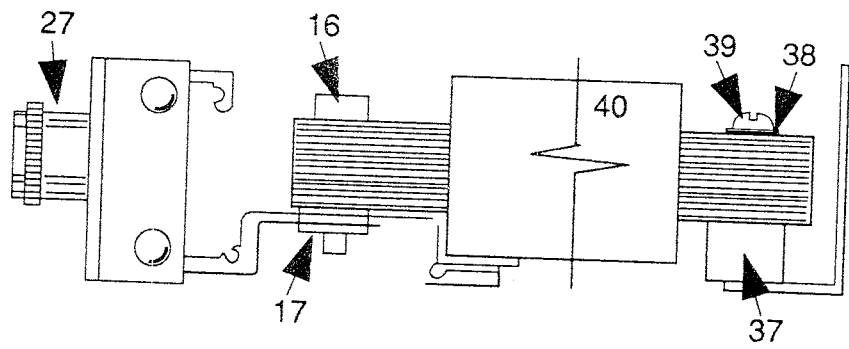

Fig. 9.3 D-75 Front Panel Assembly



**Parts List: Front Panel Assembly**

Index No.	Schematic Designation	Description	Qty.	Part No.	Misc. Info
2	DMI	.375 bright nut	1	C 1288N7	On-Off switch hardware
3		.375x.141x.031 fiber	2	C 1296-0	Output board hardware
4		#6 star lockwasher	11	C 5594-4	Output board, bridge, and terminal strip
5		#4 star lockwasher	4	C 1824-9	Crossmember hardware
6		4-40x.375 screw	4	C 5561-5	TIP47 hardware
7		6-32 hex nuts	11	C 1889-2	Output board, bridge, and D 3503-6 terminal strip
8		4-40 hex nuts	4	C 1938-7	TIP47 hardware
9		6-32x.375 screw	2	C 3879-1	D 3503-6 terminal strip
10		.375 star lockwasher	2	C 2188-8	Headphone jack and on-off switch hardware
11		.625x.375x.030 washer	1	C 2189-6	On-off switch hardware
12		.25 lockwasher	2	C 2365-2	Level control hardware
13		VH148 6 amp	1	C 3062-4	
14		.375 knurled nut	1	C 3495B2	Headphone jack hardware
15		3 conductor jack	1	C 3507-8	Headphone jack
16		Nylon transformer pin	2	D 3557-2	Transformer hardware
17		Tinnerman speed nut	2	C 3558-1	Transformer hardware
18		.625ODx.375ID washer	1	C 3628-2	(On older amps only)
19		6-32x.625 phillips	9	C 3879-1	Output brd. and bridge
20		D102,D202 D101, D201 Q108, Q208, Q112, Q212 Q109, Q209, Q112, Q212	.440x.260x.015 washer	2	C 4023-5
21	Insulating wafer (TO-3)		4	C 4039-1	Level controls
22	Red L.E.D.		2	C 4341-1	Output transistor hardware
23	Green L.E.D.		2	C 4430A0	IOC indicator
24	TIP47 driver		4	C 4647-1	Sig. presence indicator
25	NPN power transistor		4	C 4751-1	Driver transistor
26	TO-3 insulator		4	D 4071-3	Output transistor
27	.83 aluminum knob .25		1	D 4075-4	On-Off knob 10 05
28	.83 aluminum knob .12		2	D 4076-2	Level controls 3 4 01
29	4-40x.375 round head		4	C 5961-5	Crossmember hardware 11-60
30	R101, R201	25K ohm audio	2	D 4688-4	machine screw
31	F1	AGC 2.5 amp fuse	1	C 3775-1	Level controls taper pot
32		Fuse block	1	C 3776-9	(In older amps only)
33		.187x.115x.125 spacer	4	C 4759-4	Holds C 3775-1
34		Terminal strip #6 hole	1	D 3600-0	Main pc board hardware
35	SW2	Rotary power switch	1	D 3492-2	Volt. modification terminal strip
36		Cable receptacles	15	C 3849-4	On-Off switch
37		.5 transformer mount	2	C 3556-5	For connections on the main board
38		Nylon Shoulder washer	2	C 4251-2	Power transformer assy.
39		8-32x.875 round head	2	C 4252-0	Power transformer assy.
40	T1	D-75 transformer	1	D 4668-6	Transformer hardware machine screw

D 3492-2 1005  
D 4076-2 24-01  
C 9460-4 33-08

POWER SWITCH  
ITEMS

This Page Left Blank Intentionally

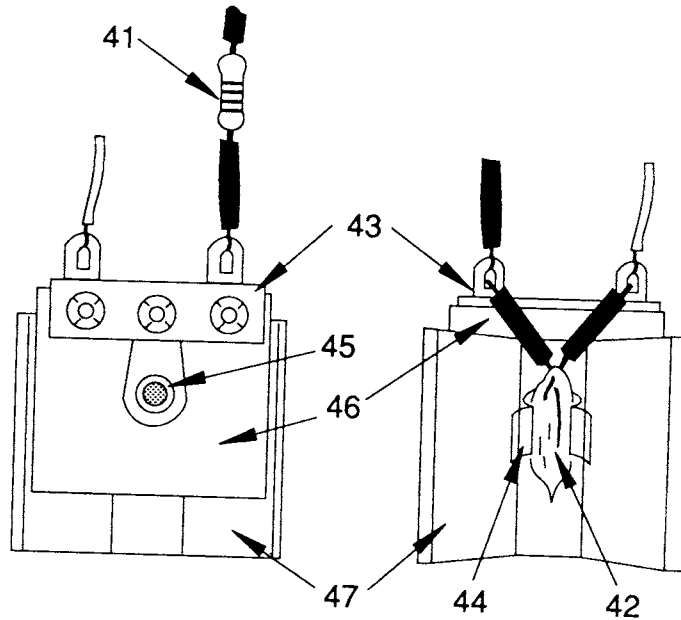

Fig. 9.4 D-75 Neon Bracket Assembly

**D-75 Neon bracket assembly**

Index No.	Schematic Designation	Description	Qty.	Part No.	Misc. Info
41	R5	27K ohm 1/2w 5cf	1	C 1056-8	
42	I1	Neon lamp NE2H	1	C 2500-4	
43		3 AUA terminal strip	1	D 1242-3	
44		SS module pipe clip	1	C 1727-4	
45		.093 steel eyelet	1	C 3529-2	
46		1.2x1.2x.015 fishpaper	1	D 4756-9	
47		Neon lamp bracket	1	D 4781-7	



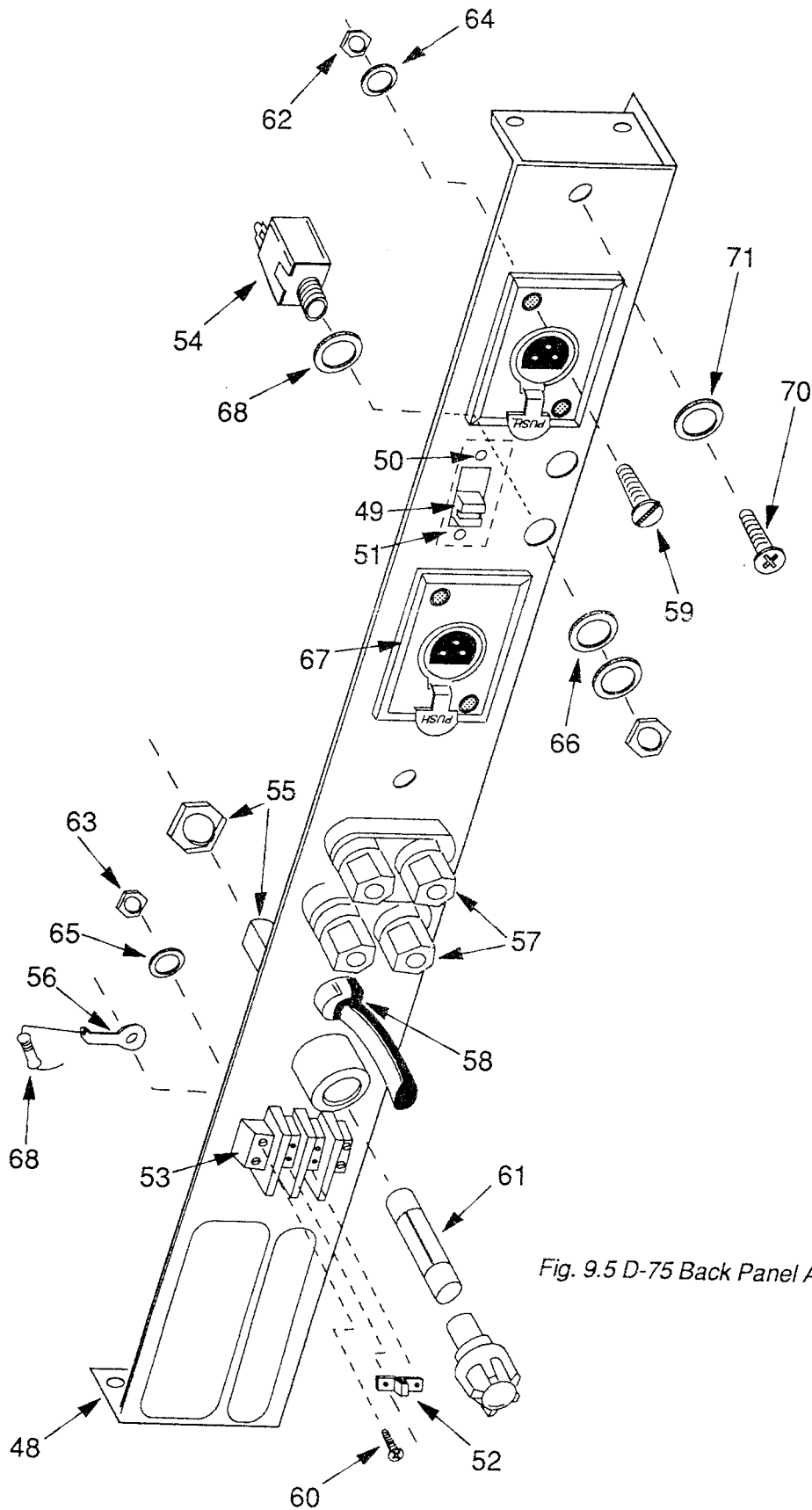

Fig. 9.5 D-75 Back Panel Assembly

**Parts List: D-75 Back Panel Assembly**

Index No.	Schematic Designation	Description	Qty.	Part No.	Misc. Info
48	SW1	D-75 back panel	1	F 9734-9	Dual-mono switch  Rear panel with C 4110-0 mounted  Input jacks  Under screw holding barrier block onto rear panel Output connectors  XLR connector hardware Barrier block hardware Phillips screw  Amcron XLR hardware Barrier block hardware XLR hardware Barrier block hardware Unbalanced input jack hardware Balanced input jacks Unbalanced input jack shoulder washer hardware Resistor
49		DPDT slide switch	1	C 4110-0	
50		Steel eyelet	2	C 3529-2	
51		D-75 rear panel switch	1	M20103A2	
52		Barrier block jumper	1	C 4726-3	
53		2 terminal barrier block	1	C 3489-9	
54		2 conductor jack	2	C 3423-8	
55		HTA fuseholder with nut	1	C 5597A5	
56		505 solder lug #8 hole	1	D 2935-1	
57		Dual binding post	2	C 2823-0	
58		HEYCO strain relief	1	C 4896-4	
59	4-40x.375 screw	4	C 2247-2		
60	6-32x.5 binding head	4	C 2176-3		
61	F1	3AG 2 amp 1.25x.25	1	C 5829-4	
61a		3AG 1 amp 1.25x.25	1	C 3065-7	
62		4-40 hex nut	4	C 1938-7	
63		6-32 hex nut	4	C 1889-2	
64		#4 star lockwasher	4	C 1824-9	
65		#6 star lockwasher	4	C 5594-4	
66		.625x.375x.015 washer	2	C 7674-2	
67		XLR female	2	C 4902-0	
68		.375 jack insulated	2	C 1306-7	
69		R6	2.7 ohm 1/2w 5cf	1	C 2857-8
70	8-32x.25 screw		2	C 5962-3	
71	#8 star lockwasher		2	C 1951-0	

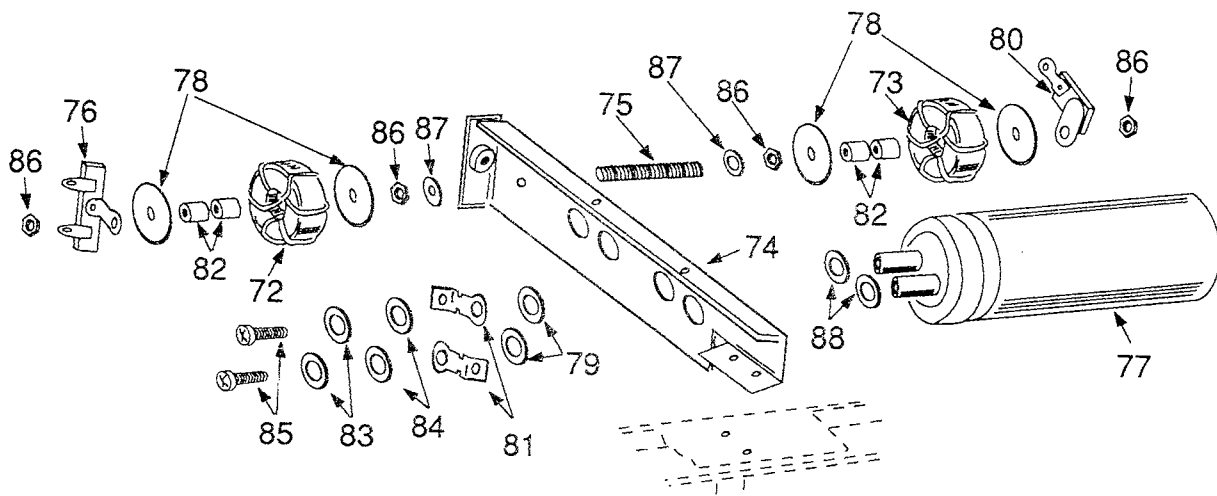

Fig. 9.6 D-75 Capacitor Bracket Assembly

## Parts List: D-75 Capacitor Bracket Assembly

Index No.	Schematic Designation	Description	Qty.	Part No.	Misc. Info
72	L103	D-75 output coil	1	M43209-2	Output coil hardware Used with output coil Power supply capacitors Output coil hardware Capacitor hardware Output coil Capacitor hardware Output coil hardware Capacitor hardware Capacitor hardware Capacitor hardware Capacitor hardware Capacitor hardware Output coil hardware Output coil hardware Capacitor hardware
73	L203	D-75 output coil	1	M43208-4	
74		D-75 Capacitor bracket	1	F10104-2	
75		8-32x2.125 stud	1	C 4738-8	
76		3 AUA terminal strip	1	D 4725-4	
77	C8, C9	10000mf 40V	2	C 4250-4	
78		.8750Dx.1871D washer	4	D 3609-1	
79		.5000Dx.1951Dx.0625	4	C 3575-9	
80		2ALUE terminal strip	1	D 3504-4	
81		389 solder lug .218 hole	4	D 2934-4	
82		3/80Dx3/16IDx1/4"	4	C 2762A8	
83		#10 star lockwasher	4	C 2279-5	
84		#8 type A plain washer	4	C 1951-0	
85		10-32x.5 truss head	4	C 2049-2	
86		8-32 hex nut	4	C 1986-6	
87		#8 star lockwasher	2	C 1951-0	
88		.75 fiber washer	4	C 1648-2	

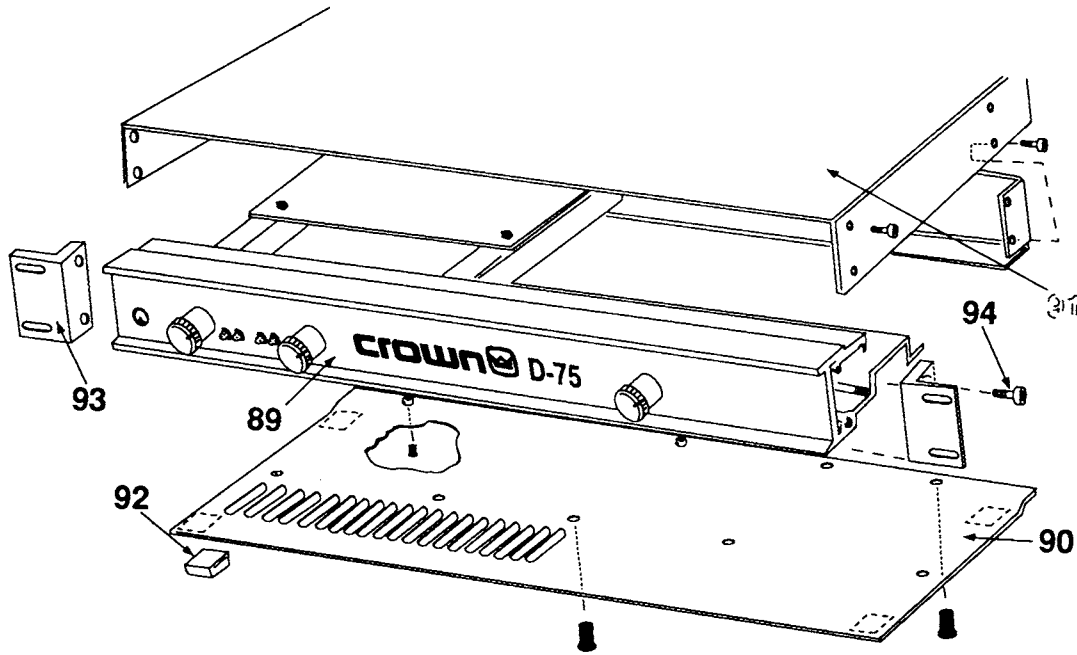

Fig. 9.7 D-75 Final Assembly

**Parts List: D-75 Final Assembly**

Index No.	Schematic Designation	Description	Qty.	Part No.	Misc. Info
89		Front panel	1	M20162-0	
89a		Lexan Overlay	1	F11023-3	
89b		AMCRON Overlay	1	F10953-2	
90		Bottom cover assembly	1	M20073K5	
91		Top cover assembly	1	F10015K6	
92		Feet	1	C 3342-0	
93		Rack ear	2	D 4800-5	
94		6-32x3/4 socket head screw	4	C 1858-7	

**Parts List: Accessory Kit**

Description	Qty	.Part No.	Misc.
(Accessory Kit)	1	(M43204-3)	
Panel screws	4	D 5263-6	
Washers	4	D 4137-2	
Dual banana plugs	2	C 2981-4	
Wire nuts	2	C 3069-9	
Fuseholder	2	C 3060-8	
Fuse 1.5 amp	2	C 2957-6	
Selfstick Feet	4	C 3342-0	Normally with fuseholder

**This Page Left Blank Intentionally**

## Appendix A: Installation

Before beginning the installation of your amplifier, please carefully note the following: It is always wise to remove power from the unit and turn the input level controls off while making connections - especially if the load is a loudspeaker system. This will eliminate any chance of loud blasts or damage to the loudspeakers.

### A.1 Mounting

The D-75 can be mounted into a standard 19 inch wide equipment rack or a custom cabinet of your own design. It occupies 1.75 inches of vertical rack space.

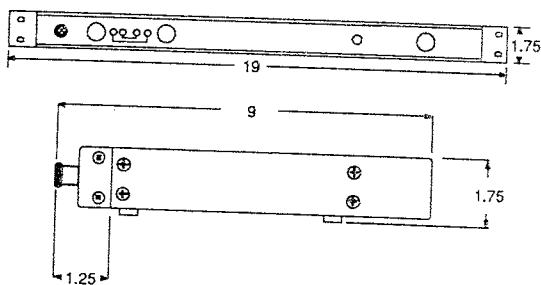

Fig. A.1 D-75 Mounting Dimensions

### A.2 Wiring

The input and output jacks are located on the rear panel. Please use care in making connections, selecting signal sources and controlling the output level. The load you save may be your own! Crown is not liable for any damage done to loads due to careless amplifier usage and deliberate overpowering.

The D-75 may be operated in either STEREO (Dual or two-channel) or MONO mode by switching the stereo-mono switch on the rear panel of the amplifier. There are VERY IMPORTANT wiring differences between these two modes which are discussed next.

#### A.2.1 STEREO

The installation is very intuitive in STEREO mode. The input of Channel 1 feeds the output of the same channel as does the input of Channel 2. To put the amplifier in stereo mode, slide the Stereo-Mono switch at the back of the amplifier downward. Be very careful not to short the two outputs together while in STEREO mode and observe correct loudspeaker polarity. The load impedance should not be less than 4 ohms at either channel.

**CAUTION:** Never parallel the two outputs by directly tying them together or parallel them with the output of any other amplifier. Such connection does not result in increased power output and can possibly cause the unit to fail.

#### A.2.2 MONO

Installing the amplifier in MONO mode is very different. MONO mode is activated when the Stereo-Mono switch is pushed upward. In this mode only the Channel 1 input should be used. **DO NOT USE THE CHANNEL 2 INPUT** or signal level. Keep the Level control of Channel 2 turned completely down.

**Note:** The input jack and Level control of Channel 2 are not defeated in MONO mode. Any signal fed into Channel 2 will beat against the signal in Channel 1.

The output wiring is very different, too. The polarity of the output of Channel 2 is inverted so it can be bridged with the output of Channel 1. The outputs of both channels receive the same signal from the input of Channel 1.

The first and most common configuration connects the positive lead from the loudspeaker to the red post or positive terminal of Channel 1 and the negative lead to the red post or positive terminal of Channel 2 (the inner black posts are not used). This method, called "bridged-mono," produces the single highest-powered output and is the configuration referred to in section 7.2 of the Specifications. The load impedance should not be less than 8 ohms in this mode.

**CAUTION:** Be certain that all equipment (meters, switches, etc.) connected to the MONO output lines are balanced. Both sides of the line must be totally isolated from the input grounds. If this is not strictly observed, severe oscillation may result.

#### A.3 Input

The unbalanced inputs have a nominal impedance of 25 K ohms and will accept most line-level outputs. The XLR inputs are 20 K ohms balanced and 10K ohms unbalanced (pin 2 is noninverting). There are three precautions to take when connecting to the inputs: 1) Keep undesirable signals off the inputs, 2) Avoid ground loops and 3) Avoid feedback between an output and an input.

Large subsonic (subaudible) frequencies are sometimes present in the input signal and can overload, overheat or otherwise damage loudspeakers. To remove such

### Input Wiring Tips

1. Use only shielded cable. The higher the density of the shield (the outer conductor), the better the cable. Spiral wrapped shield is not recommended.
2. Keep unbalanced cables as short as possible - avoid cable lengths greater than 10 feet. (Long unbalanced cables may have noticeable high-frequency loss and are at higher risk of picking up interference from other nearby components.)
3. Do not run signal cables together with high-level wiring such as loudspeaker wires or AC cords. (This greatly lessens the chance of hum or noise being induced or picked up from asymmetrical ground loops.)
4. Turn the entire system off before changing any connections and turn the level controls all the way down before powering the system back up. Crown is not liable for damage incurred when any transducer or component is overdriven.

frequencies (and any unwanted DC that may also be present), place a capacitor in series in the input signal line. The graph in Figure A.2 shows how the value of the capacitor affects the frequency response. Use only a low-leakage paper, mylar or tantalum capacitor.

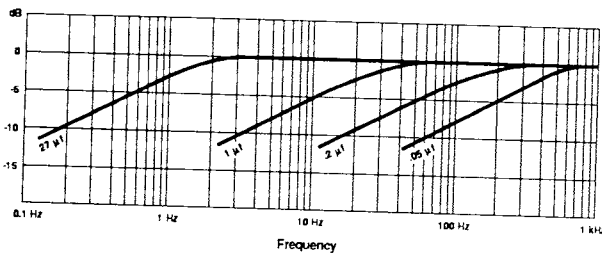

Fig. A.2 Input High Pass Filter

If large amounts of ultrasonic or RF (radio frequency) are found on the input, such as bias from tape recorders, etc., place a low-pass filter on the input. While the highest RF levels that can be reasonably expected may not damage the amplifier, they can burn out tweeters or other sensitive loads, activate the amplifier's protective system or overload the controlled-slewing-rate stage of the amp. (This latter amp stage provides RF overload protection.)

The following filters are recommended for such situations:

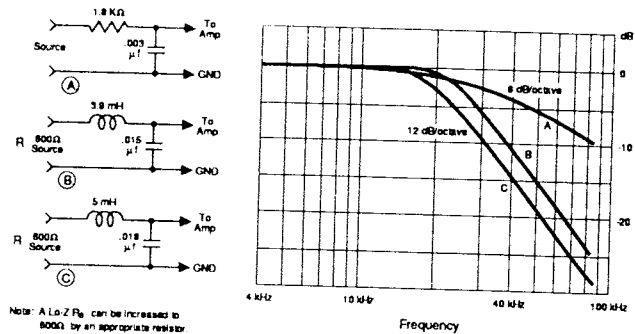

Fig. A.3 RFI (Lowpass) Filter

Another problem to prevent is ground loops - undesirable currents flowing in a grounded system, possibly causing hum in the output. A common form of loop is a pair of input cables whose area is subjected to a magnetic hum field. To prevent ground loops causing magnetic induction, lace both cables together along their length, and away from the power transformer. **DO NOT CONNECT THE INPUT AND OUTPUT GROUNDS TOGETHER.**

Yet another facet of this problem occurs when input and output grounds, tied together as in testing or metering, allow feedback oscillation from load current flowing in the loop. In some systems, even the AC power line may provide this feedback path. Proper grounding, isolation of inputs and common AC-line devices is good practice.

### A.4 Output

Consider the power handling capacity of your load before connecting it to the amplifier. Crown is not liable for damage incurred at any transducer due to its being overpowered. The use of loudspeaker protection fuses is highly recommended (see Section 3.3.4). Please also pay close attention to the Operating Precautions section (Section 4.1).

Under normal stereo conditions, a load impedance less than four ohms should not be used. The monitor output is parallel to the main outputs so any load connected to it, such as headphones, will affect the load impedance. Be careful when wiring multiple transducers to a channel. (Two 8-ohm speakers in parallel present an impedance of 4 ohms while the same two speakers in series have a 16 ohm impedance.)



Use speaker cables of sufficient gauge (thickness) for the length used. Otherwise, power is lost through cable heating and the damping factor decreased due to cable resistance. Refer to the nomograph below for recommended wire sizes (Figure 3.6). If dynamic moving-coil loudspeakers are used, find  $R_L$  by measuring the resistance of the voice coil with an ohmmeter. If electrostatic loudspeakers are used, use the rated nominal impedance of the manufacturer for  $R_L$ .

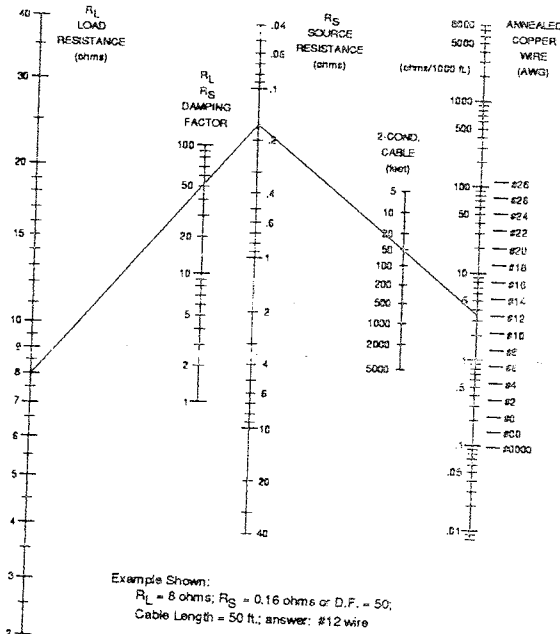

Fig. A.4 Wire -Size Nomograph

Use the nomograph as follows:

1. Note the load resistance of the speakers connected to each channel of the amplifier. Mark this value on the nomograph "Load Resistance" line.
2. Choose an acceptable system damping factor (50 is typical). Mark this value on the "Damping Factor" line.
3. Draw a pencil line through these two points, intersecting the "Source Resistance" line.
4. On the "2-Cond. Cable" line, mark the length of cable run.
5. Draw a pencil line from the intersection point on the "Source Resistance" line through the mark on the "2-Cond. Cable" line.
6. Note where the pencil line intersects the "Annealed Copper Wire" line. The value is the required gauge of speaker cable.
7. If the size of cable exceeds what you want to use, settle for a lower damping factor and try again or use more than one cable for each line. A "rule of thumb" for the latter

choice is: Every time you double the number of conductors (of equal gauge) the resulting apparent gauge is three less. For example, you determine that you need #10 AWG wire but this is too large, so you decide instead to use two #13 AWG wires in place of each #10 wire and achieve the same affect. In this same example you could also substitute four #16 AWG wires.

To prevent high-frequency oscillations:

1. Lace the loudspeaker cables together.
2. Keep the speaker cables well separated from the input cables.
3. Never connect the amplifier's input and output grounds together.
4. As a last resort, install a lowpass filter on the signal input line (see preceding Input section).

### TRANSFORMER COUPLING

Loads that are primarily inductive such as 70 V step-up transformers and electrostatic loudspeakers require special attention. To prevent large low-frequency currents from damaging the transformer (and prevent the PS-200 from unnecessarily activating its protective system) it may be necessary to install a capacitor in series with the load. If you are unsure whether this is necessary, measure the DC resistance across the terminals of each load with an ohmmeter. If the resistance you measure is less than 3 ohms either add the following parts as illustrated in Figure 3.7 or add an appropriate high-pass filter.

Place an external non-polarized capacitor of 590 to 708 mfd and a 4 ohm power resistor in series with the positive (+) lead as shown below:

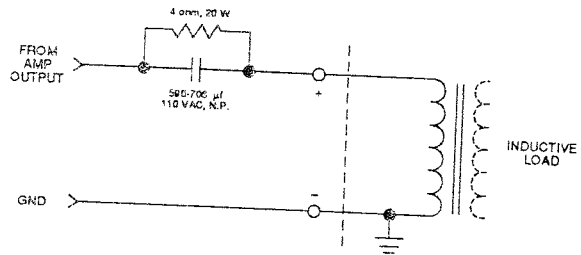

Fig. A.5 Connection to an Inductive Load

### A.5 Load Protection

We recommend that you protect your loudspeakers (or other sensitive loads) from damage resulting from excessive power. A common way to do this is to put a fuse in series with the load. The fuse may be single, fusing the overall speaker system or it may be multiple,

with one fuse on each driver.

Fuses help prevent damage due to prolonged overload, but provide essentially no protection against damage from large transients. To minimize this problem, use high-speed instrument fuses such as the Littlefuse 361000 series. Figure 3.8 is a nomograph showing fuse size versus loudspeaker peak power ratings. If, on the other hand, the loudspeaker is only susceptible to damage caused by overheating, use a fuse or circuit breaker having the same slow thermal response as the loudspeaker itself (such as a slow-blow fuse).

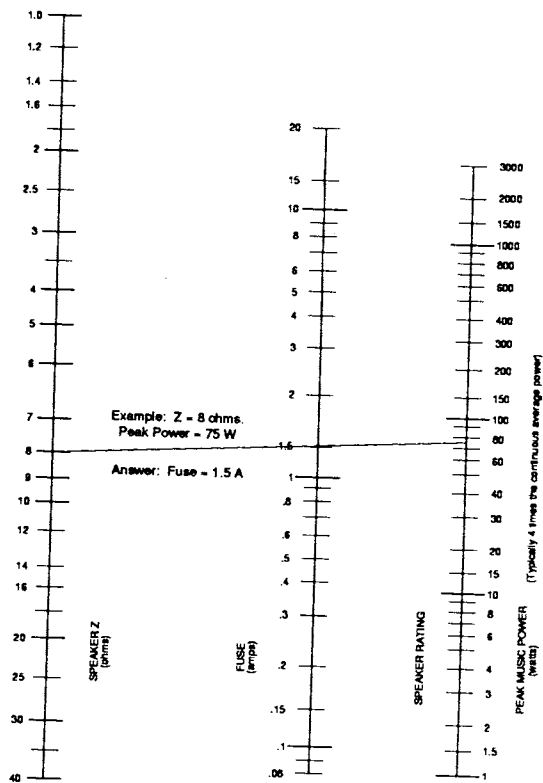

*Fig. A.6 Fuse Nomograph for Loudspeaker Protection*

### Use Good Connectors

1. Male connectors on speaker cables should not be exposed to prevent possible short circuits.
2. Connectors which might accidentally cause the two channels to be tied together during making and breaking of connections should not be used. (A common example is the standard 3-wire 1/4-inch stereo phone plug.)
3. Connectors which can be plugged into AC power receptacles should never be used.
4. Connectors having low-current-carrying capacity should not be used.
5. Connectors having any tendency to short, or having shorted leads should never be used.

## Appendix B: Operation

### B.1 Precautions

Although your amplifier is well protected from any external faults, we recommend the following precautions be taken for safe operation:

1. When using input sources of uncertain level or any audio components which have not previously been used with your amplifier, always begin with the level controls at a minimum and gradually increase them while monitoring the audio output level to avoid suddenly blasting the loudspeakers.
2. Always turn the level controls down before inserting a headphone set into the output monitor jack on the front panel. This will eliminate the risk of damaging the headset or your ears with high sound levels.
3. Turn the amplifier off and unplug it from the AC line before replacing the fuse. (The unit must be totally disconnected from the AC power source because the fuse socket is still powered even when the unit is turned off.)
4. Operate the amp with the correct fuse (2 amp for 100 or 120 VAC; 1 amp for 200, 220 or 240 VAC).
5. Never drive a transformer-coupled device (such as an electrostatic loudspeaker) or any other device which appears as a low-frequency short (less than 3 ohms) without a series isolating capacitor. Such operation may damage the load and/or needlessly activate the amplifier's VI limiting.
6. Operate the amplifier from AC mains of not more than 10% above the selected line voltage and only the specified line frequency (50/60 Hz). Failure to comply with these limits will invalidate the warranty.
7. Never connect the output to a power supply output, battery, or power main. Damage incurred by such a hookup is not covered by the warranty.
8. Do not expose the amplifier to corrosive chemicals such as soft drinks, lye, salt water, etc.
9. Do not tamper with the circuitry. Circuit changes made by unauthorized personnel, or unauthorized circuit modifications, will invalidate the warranty.

### B.2 Controls

Independent level controls and a power switch and power indicator are located on the front panel. Both level controls are used in STEREO mode, but only the Channel 1 control should be used in MONO mode. They are used to adjust the desired output level (both the monitor output and the main outputs) and have thirty one detents for precise adjustment.

The operation mode is switched between STEREO and

MONO by the Stereo-Mono switch located on the back panel. Also located on the back panel is an AC line fuse.

In addition to the above essential controls, your high-performance amplifier has an IOC (Input/Output Comparitor) indicator and a Signal Presence indicator for each channel.

The red IOC LEDs are located on the front panel above the level controls. They will flash or glow whenever the distortion specifications of the amplifier are being exceeded.

**Note:** The IOC indicators also double as STAND-BY indicators and will glow every time this feature is active (turn-on delay, Low-Frequency Interrupt and temperature overload). It is also normal for them to glow momentarily when the AC power is turned off.

The green Signal Presence LEDs are located on the front panel between the level controls. They blink or glow any time there is more than 0.6 V RMS at the output of the D-75. (If the signal level is very low they may not illuminate.) This provides a convenient method of observing whether or not a signal has been interrupted somewhere in between the input and the output.

### B.3 Protection

Crown power amplifiers are widely known for their quality construction, high reliability and extensive internal protection circuitry. The D-75 is no exception. It is protected against all the common hazards which plague high-powered amplifiers, including: shorted, open and mismatched loads (load impedance too low); overloaded power supplies; excessive temperature; chain destruction phenomena; input overload damage; and, high frequency overload blowups.

Protection against shorted and low impedance loads is provided by a fast-acting limiter circuit which instantaneously limits the output power to a maximum safe stress value. It functions automatically as a current limiter at audio frequencies whose current limiting threshold is dependent on the history of the output signal. Output current causes the threshold to increase. The no-signal threshold is high enough to allow tone bursting (even into 4 ohms) without premature limiting, as is found in some recent products of other manufacturers.

Since the limiter has no instantaneous response to output voltage, flyback transients do not appear in the output when limiting occurs on inductive loads. (Flyback transients are a normal by-product of VI limiting, also called "Energy Limiter," with an inductive load. The amplifier yields to the

inductive load which causes the load to emanate a pulse. This returned inductive energy has the opposite polarity or the original pulse - hence the name "flyback" pulse. It results in a rasping, popping distortion which is very irritating.)

Because the current limiter of the D-75 will not yield to the constant current demands of an inductive load but will sustain them, it is immune to flyback distortion.

Early amplifier designs frequently employed fixed current limiters, reducing flyback transients, but had serious difficulty obtaining reliable low frequency output - especially at full-voltage into 4 ohm loads. In addition, many early designs used fragile epi-base or triple-diffused outputs which mated poorly to the current limiting protection schemes used and resulted in low performance. The D-75 uses two multiple epitaxial silicon power transistors per channel. Their toughness allows the reliable use of a current limiter. And since limiting is adjusted to the spectral content of the signal, much larger power outputs are safely achieved.

At subsonic frequencies, it behaves as a VI limiter and provides the increased protection needed to prevent destruction due to excessive heat build-up in the half of the output stage that is being driven.

DC applied to the input should never cause accidental loudspeaker damage because of a input coupling capacitor.

All the amplifier's voltage-amplifier circuitry is designed to

be inherently current-limited. Thereby, if any of the devices should fail (which is extremely unlikely) no damage will occur to the rest of the stages.

The AC line for 100 or 120 V is fused with a 2 A fuse. For 200, 220 or 240 VAC, a 1 A fuse is used. The use of any other type or size fuse will invalidate the warranty.

The input stage is protected against excessive input signal level (overdrive) by a series-limiting resistor.

The amplifier features a controlled slew rate which, coupled with the protection circuits, guards the amplifier from blowups when fed large RF input signals.

#### B.4 Fuse Replacement

An AC line fuse is located next to the power cord on the back panel of the amplifier. To replace the fuse, first **TURN OFF THE POWER SWITCH AND DISCONNECT THE POWER PLUG FROM THE POWER SOURCE.** Unscrew the cap of the fuse holder and remove the fuse.

Replace the fuse with a 2 amp fuse for 100 or 120 VAC operation and a 1 amp fuse for 200, 220 or 240 VAC operation. Reassemble in reverse order.

**IMPORTANT:** The fuse holder still has power even when the power switch is turned off. **ALWAYS DISCONNECT AC POWER BEFORE REPLACING FUSES.**